

阅读申明

- 1.本站收集的数据手册和产品资料都来自互联网，版权归原作者所有。如读者和版权方有任何异议请及时告之，我们将妥善解决。
- 2.本站提供的中文数据手册是英文数据手册的中文翻译，其目的是协助用户阅读，该译文无法自动跟随原稿更新，同时也可能存在翻译上的不当。建议读者以英文原稿为参考以便获得更精准的信息。
- 3.本站提供的产品资料，来自厂商的技术支持或者使用者的心得体会等，其内容可能存在描述上的差异，建议读者做出适当判断。
- 4.如需与我们联系，请发邮件到marketing@iczoom.com，主题请标有“数据手册”字样。

Read Statement

1. The datasheets and other product information on the site are all from network reference or other public materials, and the copyright belongs to the original author and original published source. If readers and copyright owners have any objections, please contact us and we will deal with it in a timely manner.
2. The Chinese datasheets provided on the website is a Chinese translation of the English datasheets. Its purpose is for reader's learning exchange only and do not involve commercial purposes. The translation cannot be automatically updated with the original manuscript, and there may also be improper translations. Readers are advised to use the English manuscript as a reference for more accurate information.
3. All product information provided on the website refer to solutions from manufacturers' technical support or users the contents may have differences in description, and readers are advised to take the original article as the standard.
4. If you have any questions, please contact us at marketing@iczoom.com and mark the subject with "Datasheets" .

EEPROM PROGRAMMABLE VCXO CLOCK GENERATOR
IDT5V19EE903
Description

The IDT5V19EE903 is a programmable clock generator intended for high performance data-communications, telecommunications, consumer, and networking applications. There are four internal PLLs, each individually programmable, allowing for four unique non-integer-related frequencies. The frequencies are generated from a single reference clock. The reference clock can come from one of the two redundant clock inputs. Automatic or manual switchover function allows any one of the redundant clocks to be selected during normal operation.

The IDT5V19EE903 is in-system, programmable and can be programmed through the use of I²C interface. An internal EEPROM allows the user to save and restore the configuration of the device without having to reprogram it on power-up.

Each of the four PLLs has an 7-bit reference divider and a 12-bit feedback divider. This allows the user to generate four unique non-integer-related frequencies. The PLL loop bandwidth is programmable to allow the user to tailor the PLL response to the application. For instance, the user can tune the PLL parameters to minimize jitter generation or to maximize jitter attenuation. Spread spectrum generation and/or fractional divides are allowed on two of the PLLs.

There are a total of six 8-bit output dividers. The outputs are connected to the PLLs via a switch matrix. The switch matrix allows the user to route the PLL outputs to any output bank. This feature can be used to simplify and optimize the board layout. In addition, each output's slew rate and enable/disable function is programmable.

Features

- Four internal PLLs
- Internal non-volatile EEPROM
- Fast (400kHz) mode I²C serial interface
- Input frequency range: 1 MHz to 200 MHz
- Output frequency range: 4.9 kHz to 200 MHz
- Reference crystal input with programmable linear load capacitance
 - Crystal frequency range: 8 MHz to 50 MHz (maximum crystal range is best effort)
- Integrated VCXO
- Each PLL has a 7-bit reference divider and a 12-bit feedback-divider
- 8-bit output-divider blocks
- Fractional division capability on one PLL
- Two of the PLLs support spread spectrum generation capability
- I/O Standards:
 - Outputs - 3.3 V LVTTTL/ LVCMOS
 - Inputs - 3.3 V LVTTTL/ LVCMOS
- Programmable slew rate control
- Programmable loop bandwidth
- Programmable output inversion to reduce bimodal jitter
- Redundant clock inputs with auto and manual switchover options
- Individual output enable/disable
- Power-down mode
- 3.3V core V_{DD}
- Available in TSSOP and VFQFPN packages
- -40 to +85 C Industrial Temp operation

Functional Block Diagram

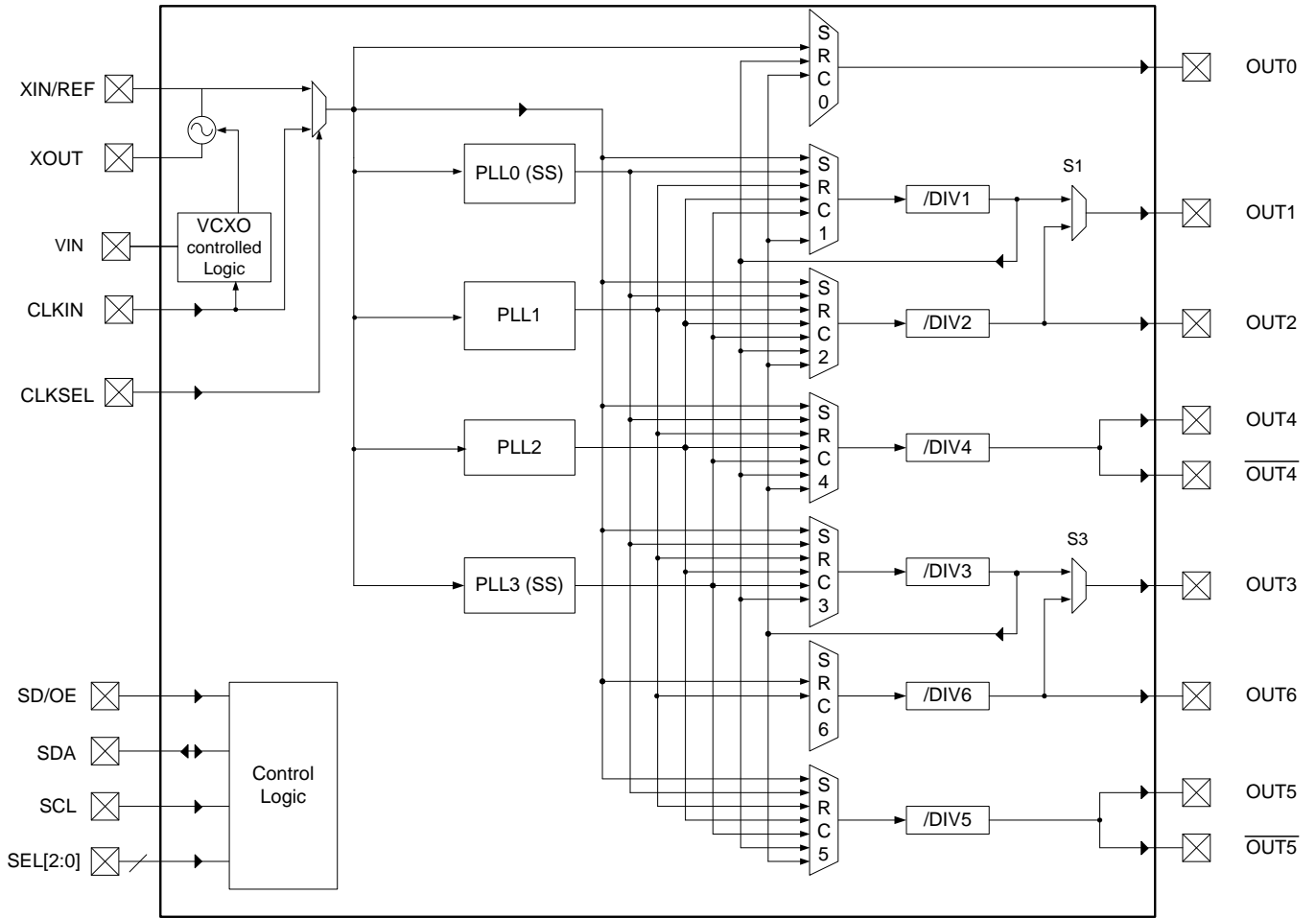

2. CLKIN, CLKSEL, SD/OE and SEL[2:0] have pull down resistors.

Pin Configurations

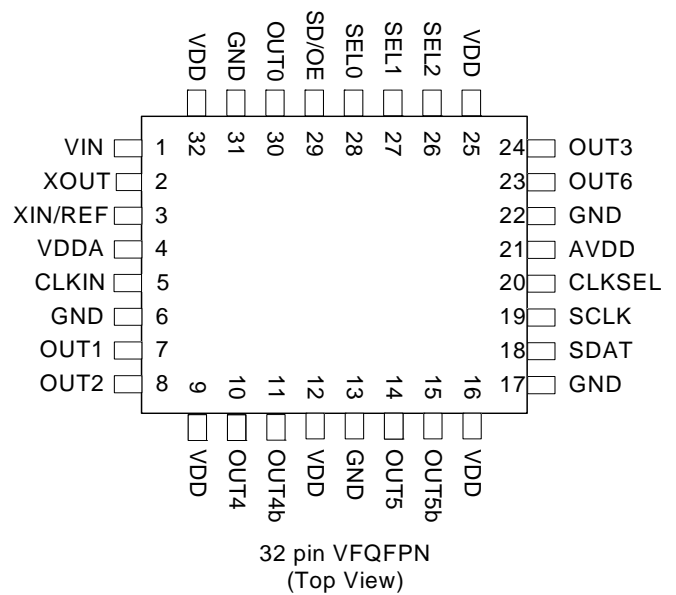
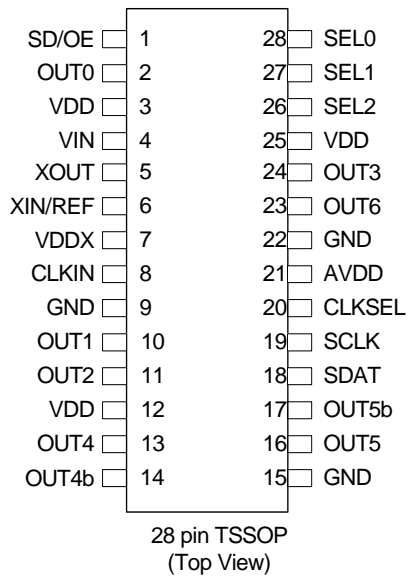

Pin Descriptions

Pin Name	PG28 Pin#	NL32 Pin#	I/O	Pin Type	Pin Description
VIN	4	1	I	LVTTL	VCXO analog control voltage input. Pulls output ± 100 ppm by varying from 0V to 3.3V.
CLKIN	8	5	I	LVTTL	Input clock. Weak internal pull down resistor.
XOUT	5	2	O	LVTTL	CRYSTAL_OUT -- Reference crystal feedback.
XIN / REF	6	3	I	LVTTL	CRYSTAL_IN -- Reference crystal input or external reference clock input.
SDAT	18	18	I/O	Open Drain	Bidirectional I ² C data. An external pull-up resistor is required. See I ² C specification for pull-up value recommendation.
SCLK	19	19	I	LVTTL	I ² C clock. Weak internal pull down resistor. An external pull-up resistor is required. See I ² C specification for pull-up value recommendation.
CLKSEL	20	20	I	LVTTL	Input clock selector. Weak internal pull down resistor.
SEL2	26	26	I	LVTTL	Configuration select pin. Weak internal pull down resistor.
SEL1	27	27	I	LVTTL	Configuration select pin. Weak internal pull down resistor.
SEL0	28	28	I	LVTTL	Configuration select pin. Weak internal pull down resistor.
SD/OE	1	29	I	LVTTL	Enables/disables the outputs or powers down the chip. The SP bit (0x02) controls the polarity of the signal to be either active HIGH or LOW. (Default is active LOW.) Weak internal pull down resistor.

Pin Name	PG28 Pin#	NL32 Pin#	I/O	Pin Type	Pin Description
OUT0	2	30	O	LVTTL	Configurable clock output 0.
OUT1	10	7	O	LVTTL	Configurable clock output 1.
OUT2	11	8	O	LVTTL	Configurable clock output 2.
OUT3	24	24	O	LVTTL	Configurable clock output 3.
OUT4	13	10	O	LVTTL ¹	Configurable clock output 4.
OUT4b	14	11	O	LVTTL ¹	Configurable clock output 4b.
OUT5	16	14	O	LVTTL ¹	Configurable clock output 5.
OUT5b	17	15	O	LVTTL ¹	Configurable clock output 5b.
OUT6	23	23	O	LVTTL	Configurable clock output 6.
VDD	25	9, 12, 16, 25, 32		Power	Device power supply. Connect to 3.3V.
VDDx	7	4		Power	Crystal oscillator power supply. Connect to 3.3V through 5Ω resistor. Use filtered analog power supply if available.
AVDD	21	21		Power	Device analog power supply. Connect to 3.3V. Use filtered analog power supply if available.
GND	9, 15, 22	6, 13, 17, 22, 31, PAD		Power	Connect to Ground.

1. When only an individual single-ended clock output is required, tie OUT# and OUT#b together.

2. Analog power plane should be isolated from a 3.3V power plane through a ferrite bead.

3. Each power pin should have a dedicated 0.01μF de-coupling capacitor. Digital VDDs may be tied together.

4. Unused clock inputs (REFIN or CLKIN) must be pulled high or low - they cannot be left floating. If the crystal oscillator is not used, XOUT must be left floating.

PLL Features and Descriptions

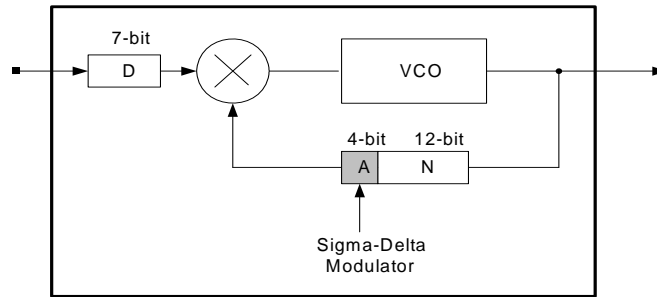

PLL0 Block Diagram

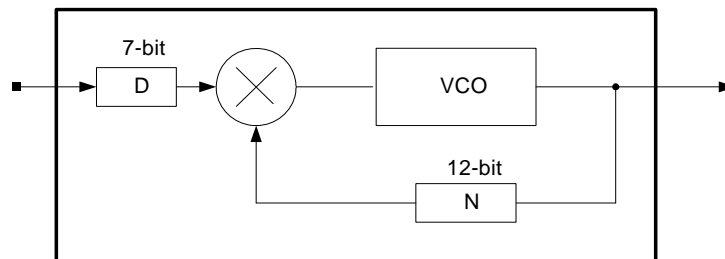

PLL1, PLL2 and PLL3 Block Diagram

	Pre-Divider (D) ¹ Values	Multiplier (M) ² Values	Programmable Loop Bandwidth	Spread Spectrum Generation Capability
PLL0	1 - 127	10 - 8206	Yes	Yes
PLL1	1 - 127	1 - 4095	Yes	No
PLL2	1 - 127	1 - 4095	Yes	No
PLL3	3 - 127	12 - 4095	Yes	Yes

1. For PLL0, PLL1 and PLL2, D=0 means PLL power down. For PLL3, 0, 1, and 2 are DNU (do not use)
 2. For PLL0, $M = 2 \cdot N + A + 1$ (for $A > 0$); $M = 2 \cdot N$ (for $A = 0$); $A \leq N - 1$. For PLL1, PLL2 and PLL3, $M = N$.

Reference Clock Input Pins and Selection

The IDT5V19EE903 supports up to two clock inputs. One of the clock inputs (XIN/ REF) can be driven by either an external crystal or a reference clock. The second clock input (CLKIN) can only be driven from an external reference clock. The CLKSEL pin selects the input clock from either XTAL/REF or CLKIN.

Either clock input can be set as the primary clock. The primary clock designation is to establish which is the main reference clock to the PLLs. The non-primary clock is designated as the secondary clock in case the primary clock goes absent and a backup is needed. The PRIMSRC bit (0xBE through 0xC3) determines which clock input will be selected as primary clock. When PRIMSRC bit is "0", XIN/REF is selected as the primary clock, and when "1", CLKIN as the primary clock.

The two external reference clocks can be manually selected using the CLKSEL pin. The SM bits (0xBE through 0xC3) must be set to "0x" for manual switchover which is detailed in SWITCHOVER MODES section.

Crystal Input (XIN/REF)

The crystal used should be a fundamental mode quartz crystal; overtone crystals should not be used.

When the XIN/REF pin is driven by a crystal, it is important to set the internal inverter oscillator drive strength and tuning/load capacitor values correctly to achieve the best clock performance. These values are programmable through I²C interface to allow for maximum compatibility with crystals from various manufacturers, processes, performances, and qualities. The internal load capacitors are true parallel-plate capacitors for ultra-linear performance. Parallel-plate capacitors were chosen to reduce the frequency shift that occurs when non-linear load capacitance interacts with load, bias, supply, and temperature changes. External non-linear crystal load capacitors should not be used for applications that are sensitive to absolute frequency requirements. The value of the internal load capacitors are determined by XTAL[4:0] bits. The load capacitance can be set with a resolution of 0.125 pF for a total crystal load ranging from 3.5 pF to 7.5 pF. Check with the crystal vendor's load capacitance specification for the exact setting to tune the internal load capacitor. The following equation governs how the total

internal load capacitance is set.

$$\text{XTAL load cap} = 3.5 \text{ pF} + \text{XTAL}[4:0] * 0.125 \text{ pF (Eq. 1)}$$

Parameter	Bits	Step (pF)	Min (pF)	Max (pF)
XTAL	8	0.125	0	4

When using an external reference clock instead of a crystal on the XTAL/REF pin, the input load capacitors may be completely bypassed. This allows for the input frequency to be up to 200 MHz. When using an external reference clock, the XOUT pin must be left floating, XTAL must be programmed to the default value of "00h", and the crystal drive strength bit, XDRV (0x06), must be set to the default value of "11h".

Switchover Modes

The IDT5V19EE903 features redundant clock inputs which supports both Automatic and Manual switchover mode. These two modes are determined by the configuration bits, SM (0xBE through 0xC3). The primary clock source can be programmed, via the PRIMSRC bit, to be either XIN/REF or CLKIN. The other clock input will be considered as the secondary source. Note that the switchover modes are asynchronous. If the reference clocks are directly routed to OUTx with no phase relationship, short pulses can be generated during switchover. The automatic switchover mode will work only when the primary clock source is XIN/REF. Switchover modes are not supported for crystal input configurations.

Manual Switchover Mode

When SM[1:0] is "0x", the redundant inputs are in manual switchover mode. In this mode, CLKSEL pin is used to switch between the primary and secondary clock sources. As previously mentioned, the primary and secondary clock source setting is determined by the PRIMSRC bit. During the switchover, no glitches will occur at the output of the device, although there may be frequency and phase drift, depending on the exact phase and frequency relationship between the primary and secondary clocks.

Automatic Switchover Mode

The redundant inputs are in automatic switchover mode. Automatic switchover mode has revertive functionality. The input clock selection will switch to the secondary clock source when there are no transitions on the primary clock source for two secondary clock cycles. If both reference

clocks are at different frequencies, the device will always remain on the primary clock unless it is absent for two secondary clock cycles. The secondary clock must always run at a frequency less than or equal to the primary clock frequency.

Reference Divider, Feedback Divider, and Output Divider

Each PLL incorporates a 7-bit reference divider (D[6:0]) and a 12-bit feedback divider (N[11:0]) that allows the user to generate four unique non-integer-related frequencies. Each output divide supports 8-bit output-divider (PM and Q[7:0]). The following equation governs how the output frequency is calculated.

$$F_{OUT} = \frac{F_{IN} * \left(\frac{M}{D}\right)}{ODIV} \quad (\text{Eq. 1})$$

Where FIN is the reference frequency, M is the total feedback-divider value, D is the reference divider value, ODIV is the total output-divider value, and FOUT is the resulting output frequency.

For PLL0,

$$M = 2 * N + A + 1 \quad (\text{for } A > 0)$$

$$M = 2 * N \quad (\text{for } A = 0)$$

For PLL1, PLL2 and PLL3,

$$M = N$$

PM and Q[6:0] are the bits used to program the 8-bit output-dividers for outputs OUT1-6. OUT0 does not have any output divide along its path. The 8-bit output-dividers will bypass or divide down the output banks' frequency with even integer values ranging from 2 to 256.

There is the option to choose between disabling the output-divider, utilizing a div/1, a div/2, or the 7-bit Q-divider by using the PM bit. If the output is disabled, it will be driven High, Low or High Impedance, depending on OEM[1:0]. Each bank, except for OUT0, has a PM bit. When disabled, no clocks will appear at the output of the divider, but will remain powered on. The output divides selection table is shown below.

Q[6:0]	PM	Output Divider
111 1111	0	Disabled
	1	/1
<111 1111	0	/2
	1	/((Q[6:0] + 2) * 2)

Note that the actual 7-bit Q-divider value has a 2 added to the integer value Q and the outputs are routed through another div/2 block. The output divider should never be disabled unless the output bank will never be used during normal operation. The output frequency range are from 4.9KHz to 200MHz.

Spread Spectrum Generation (PLL0)

PLL0 supports spread spectrum generation capability, which users have the option of turning on or off. Spread spectrum profile, frequency, and spread amplitude are fully programmable. The programmable spread spectrum generation parameters are TSSC[3:0], NSSC[2:0], SS_OFFSET[5:0], SD[3:0], DITH, and X2 bits. These bits are in the memory address from 0xAC to 0xBD for PLL0. The spread spectrum generation on PLL0 can be enabled/disabled using the TSSC[3:0] bits. To enable spread spectrum, set TSSC > '0' and set NSSC[2:0], SS_OFFSET[5:0], SD[3:0], and the A[3:0] (in the total M value) accordingly. To disable spread spectrum generation, set TSSC = '0'.

TSSC[3:0]

These bits are used to determine the number of phase/frequency detector cycles per spread spectrum cycle (ssc) steps. The modulation frequency can be calculated with the TSSC bits in conjunction with the NSSC bits. Valid TSSC integer values for the modulation frequency range from 5 to 14. Values of 0 - 4 and 15 should not be used.

NSSC[2:0]

These bits are used to determine the number of delta-encoded samples used for a single quadrant of the spread spectrum waveform. All four quadrants of the spread spectrum waveform are mirror images of each other. The modulation frequency is also calculated based on the NSSC bits in conjunction with the TSSC bits. Valid NSSC integer values range from 1 to 6. Values of 0 and 7 should not be used.

SS_OFFSET[5:0]

These bits are used to program the fractional offset with respect to the nominal M integer value. For center spread, the SS_OFFSET is set to '0' so that the spread spectrum waveform is centered about the nominal M (Mnom) value. For down spread, the SS_OFFSET > '0' such the spread spectrum waveform is centered about the (Mideal -1 +SS_Offset) value. The downspread percentage can be thought of in terms of center spread. For example, a downspread of -1% can also be considered as a center spread of ±0.5% but with Mnom shifted down by one and offset. The SS_OFFSET has integer values ranging from 0 to 63.

SD[3:0]

These bits are used to shape the profile of the spread spectrum waveform. These are delta-encoded samples of the waveform. There are twelve sets of SD samples. The NSSC bits determine how many of these samples are used for the waveform. The sum of these delta-encoded samples (sigma delta- encoded samples) determine the amount of spread and should not exceed (63 - SS_OFFSET). The maximum spread is inversely proportional to the nominal M integer value.

DITH

This bit is used for dithering the sigma-delta-encoded samples. This will randomize the least-significant bit of the input to the spread spectrum modulator. Set the bit to '1' to enable dithering.

X2

This bit will double the total value of the sigma-delta-encoded-samples which will increase the amplitude of the spread spectrum waveform by a factor of two. When X2 is '0', the amplitude remains nominal but if set to '1', the amplitude is increased by x2. The following equations govern how the spread spectrum is set:

$$T_{SSC} = TSSC[3:0] + 2 \text{ (Eq. 2)}$$

$$N_{SSC} = NSSC[2:0] * 2 \text{ (Eq. 3)}$$

$$SD[3:0]_k = S_{j+1}(\text{unencoded}) - S_j(\text{unencoded}) \text{ (Eq. 4)}$$

where S_j is the unencoded sample out of a possible 12 and SD_k is the delta-encoded sample out of a possible 12.

$$\text{Amplitude} = ((2*N[11:0] + A[3:0] + 1) * \text{Spread\%} / 100) / 2 \text{ (Eq. 5)}$$

if $1 < \text{Amplitude} < 2$, then set X2 bit to '1'.

Modulation frequency:

$$F_{PPFD} = F_{IN} / D \text{ (Eq. 6)}$$

$$F_{VCO} = F_{PPFD} * M_{NOM} \text{ (Eq. 7)}$$

$$F_{SSC} = F_{PPFD} / (4 * N_{SSC} * T_{SSC}) \text{ (Eq. 8)}$$

Spread:

$$\Sigma\Delta = SD_0 + SD_1 + SD_2 + \dots + SD_{11}$$

the number of samples used depends on the Nssc value

$$\Sigma\Delta \leq 63 - SS_OFFSET$$

$$\pm\text{Spread\%} = (\Sigma\Delta * 100) / (64 * (2*N[11:0] + A[3:0] + 1)) \text{ (Eq. 9)}$$

$$\pm\text{Max Spread\%} / 100 = 1 / M_{NOM} \text{ or } 2 / M_{NOM} (X2=1)$$

Profile:

Waveform starts with SS_OFFSET, SS_OFFSET + SD_J, SS_OFFSET + SD_{J+1}, etc.

Spread Spectrum Using Sinusoidal Profile

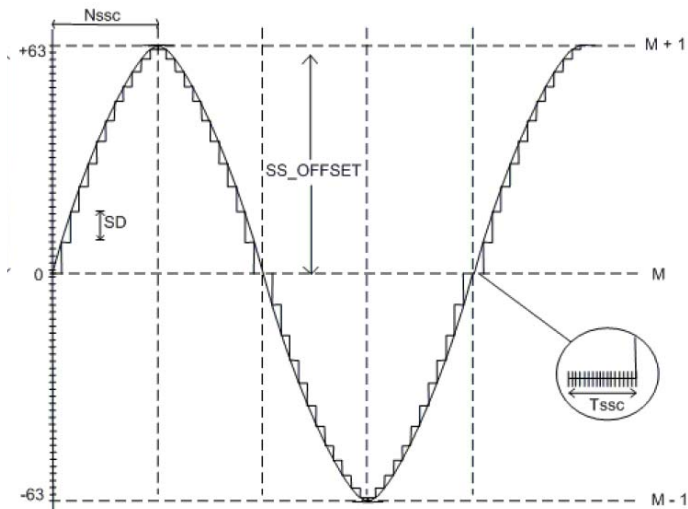

Example

F_{IN} = 25MHz, F_{OUT} = 100MHz, F_{SSC} = 33KHz with center spread of ±2%. Find the necessary spread spectrum register settings.

Since the spread is center, the SS_OFFSET can be set to '0'. Solve for the nominal M value; keep in mind that the nominal M should be chosen to maximize

the VCO. Start with D = 1, using Eq.6 and Eq.7.

$$M_{NOM} = 1200MHz / 25MHz = 48$$

Using Eq.4, we arbitrarily choose N = 22, A = 3. Now that we have the nominal M value, we can determine TSSC and NSSC by using Eq.8.

$$Nssc * Tssc = 25MHz / (33KHz * 4) = 190$$

However, using Eq. 2 and Eq.3, we find that the closest value is when TSSC = 14 and NSSC = 6. Keep in mind to maximize the number of samples used

to enhance the profile of the spread spectrum waveform.

$$Tssc = 14 + 2 = 16$$

$$Nssc = 6 * 2 = 12$$

$$Nssc * Tssc = 192$$

Use Eq.10 to determine the value of the sigma-delta-encoded samples.

$$\pm 2\% = (\Sigma\Delta * 100)/(64 * 48)$$

$$\Sigma\Delta = 61.4$$

Either round up or down to the nearest integer value. Therefore, we end up with 61 or 62 for sigma-delta-encoded samples. Since the sigma-delta-encoded samples must not exceed 63 with SS_OFFSET set to '0', 61 or 62 is well within the limits. It is the discretion of the user to define the shape of the profile that is better suited for the intended application.

Using Eq. 9 again, the actual spread for the sigma-delta-encoded samples of 56 and 57 are ±1.99% and ±2.02%, respectively.

Use Eq.10 to determine if the X2 bit needs to be set;

$$Amplitude = 48 * (1.99 \text{ or } 2.02) / 100/2 = 0.48 < 1$$

Therefore, the X2 = '0'. The dither bit is left to the discretion of the user.

The example above was of a center spread using spread spectrum. For down spread, the nominal M value can be set one integer value lower to 47.

Note that the IDT5V19EE903 should not be programmed with TSSC > '0', SS_OFFSET = '0', and SD = '0' in order to prevent an unstable state in the modulator.

The PLL loop bandwidth must be at least 10x the modulation frequency along with higher damping (larger ωz) to prevent the spread spectrum from being filtered and reduce extraneous noise. Refer to the LOOP FILTER section for more detail on ωz. The A[3:0] must be used for spread spectrum, even if the total multiplier value is an even integer.

Spread Spectrum Generation (PLL3)

PLL3 support spread spectrum generation capability, which users have the option of turning on and off. Spread spectrum profile, frequency, and spread are fully programmable (within limits). The technique is different from that used in PLL0. The programmable spread spectrum generation parameters are SS_D3[7:0], SSVCO[15:0], SSENb, IP3[4:0] and RZ3[3:0] bits. These bits are in the memory address range of 0x4C to 0x85 for PLL3. The spread spectrum generation on PLL3 can be enabled/disabled using the SSENb bit. To enable spread spectrum, set SSENb = '1'.

For Spread Enabled:

Spread spectrum is configured using SS_D3(spread spectrum reference divide)

$$SS_D3 = \frac{F_{IN}}{4 * F_{MOD}} \quad (\text{Eq. 10})$$

and SSVCO (spread spectrum loop feedback counter).

$$SSVCO = [0.5 * \frac{F_{VCO}}{F_{MOD}} * (1 + SS/400) + 5] \quad (\text{Eq. 11})$$

SS is the total Spread Spectrum amount (I.e. center spread $\pm 0.5\%$ has a total spread of 1.0% and down spread -0.5% has a total spread of 0.5%.)

Loop Filter

The loop filter for each PLL can be programmed to optimize the jitter performance. The low-pass frequency response of the PLL is the mechanism that dictates the jitter transfer characteristics. The loop bandwidth can be extracted from the jitter transfer. A narrow loop bandwidth is good for jitter attenuation while a wide loop bandwidth is best for low-jitter frequency generation. The specific loop filter components that can be programmed are the resistor via the RZ[3:0] bits, zero capacitor via the CZ bit (for PLL0, PLL1 and PLL2), and the charge pump current via the IP[2:0] bits (for PLL0, PLL1 and PLL2) or IP[3:0] (for PLL3).

The following equations govern how the loop filter is set for PLL0 - PLL2:

$$\text{Resistor (Rz)} = (RZ[0] + 2 * RZ[1] + 4 * RZ[2] + 8 * RZ[3]) * 4.0 \text{ kOhm}$$

$$\text{Zero capacitor (Cz)} = 196 \text{ pF} + CZ * 217 \text{ pF}$$

$$\text{Pole capacitor (Cp)} = 15 \text{ pF}$$

$$\text{Charge pump (Ip)} = 6 * (IP[0] + 2 * IP[1] + 4 * IP[2]) \text{ uA}$$

$$\text{VCO gain (Kvco)} = 900 \text{ MHz/V} * 2\pi$$

The following equations govern how the loop filter is set for PLL3:

For Non-Spread Spectrum Operation:

$$\text{Resistor(Rz)} = \frac{(12.5 + 12.5 * (RZ[1] + 2 * RZ[2] + 4 * RZ[3]))}{* RZ[0] + 6 * (1 - RZ[0])} \text{ kOhms (Eq. 12)}$$

For Spread Spectrum Operation:

$$\text{Resistor(Rz)} = \frac{(62.5 + 12.5 * (RZ[1] + 2 * RZ[2] + 4 * RZ[3]))}{* RZ[0] + 6 * (1 - RZ[0])} \text{ kOhms (Eq. 13)}$$

$$\text{Zero capacitor (Cz)} = 250 \text{ pF}$$

$$\text{Pole capacitor (Cp)} = 15 \text{ pF}$$

For Non-Spread Spectrum Operation:

$$\text{Charge pump (Ip)} = \frac{24 * (1 + (2 * IP[0]) + (4 * IP[1]) + (8 * IP[2]))}{3 + (5 * IP[3]) + (11 * IP[4])} \text{ A (Eq. 14)}$$

For Spread Spectrum Operation:

$$\text{Charge pump (Ip)} = \frac{12 * (1 + (2 * IP[0]) + (4 * IP[1]) + (8 * IP[2]))}{27 + (5 * IP[3]) + (11 * IP[4])} \text{ A (Eq. 14)}$$

$$\text{VCO gain (Kvco)} = 900 \text{ MHz/V} * 2\pi$$

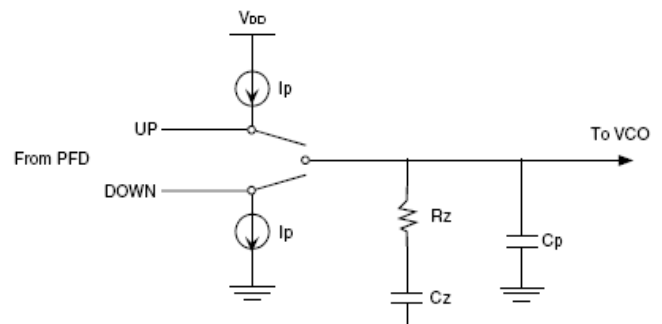

PLL Loop Bandwidth:

$$\text{Charge pump gain (K}\phi) = I_p / 2\pi$$

$$\text{VCO gain (K}_{vco}) = 900 \text{ MHz/V} * 2\pi$$

M = Total multiplier value (See the Reference Divider, Feedback Divider and Output Divider section for more detail)

$$\omega_c = (R_z * K\phi * K_{vco} * C_z) / (M * (C_z + C_p))$$

$$F_c = \omega_c / 2\pi$$

Note, the phase/frequency detector frequency (F_{PFD}) is typically seven times the PLL closed-loop bandwidth (F_c) but too high of a ratio will reduce the phase margin thus compromising loop stability.

To determine if the loop is stable, the phase margin (ϕ_m) needs to be calculated as follows.

Phase Margin:

$$\omega_z = 1 / (R_z * C_z)$$

$$\omega_p = (C_z + C_p) / (R_z * C_z * C_p)$$

$$\phi_m = (360 / 2\pi) * [\tan^{-1}(\omega_c / \omega_z) - \tan^{-1}(\omega_c / \omega_p)]$$

To ensure stability in the loop, the phase margin is recommended to be $> 60^\circ$ but too high will result in the lock time being excessively long. Certain loop filter parameters would need to be compromised to not only meet a required loop bandwidth but to also maintain loop stability.

SEL[2:0] Function

The IDT5V19EE903 can support up to six unique configurations. Users may pre-programmed all these configurations, and select the configurations using SEL[2:0] pins. Alternatively, users may use I²C interface to configure these registers on-the-fly.

SEL2	SEL1	SEL0	Configuration Selections
0	0	0	Select CONFIG0
0	0	1	Select CONFIG1
0	1	0	Select CONFIG2
0	1	1	Select CONFIG3
1	0	0	Select CONFIG4
1	0	1	Select CONFIG5
1	1	0	Reserved (Do not use)
1	1	1	Reserved (Do not use)

Crystal/Clock Selection

XTCLKSEL bit is used to bypass a crystal oscillator circuit when external clock source is used.

PRMSRC bit is used to select a primary clock from XIN/REF and CLKIN.

PRMSRC bit	Primary	Secondary
0	XIN/REF	CLKIN
1	CLKIN	XIN/REF

CLKSEL input	Clock Source
0	Primary Clock Source
1	Secondary Clock Source

CLKSEL	PRMSRC	Reference Clock
0	0	XIN/REF
0	1	CLKIN
1	0	CLKIN
1	1	XIN/REF

SMx[1:0]	Switcing Mode	Primary to Secondary	Secondary to Primary
0x	Manual	No	No
10	Auto	Yes	No
11	Auto-Revertive	Yes	Yes

SD/OE Pin Function

The polarity of the SD/OE signal pin can be programmed to be either active HIGH or LOW with the SP bit (0x02). When SP is “0” (default), the pin becomes active LOW and when SP is “1”, the pin becomes active HIGH. The SD/OE pin can be configured as either to shutdown the PLLs or to enable/disable the outputs.

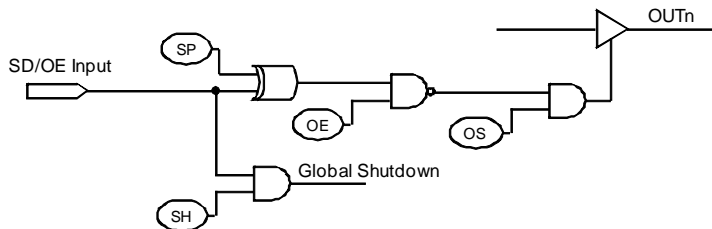

Truth Table

SH bit	SP bit	OSn bit	OEn bit	SD/OE	OUTn
0	0	0	x	x	High-Z ²
0	0	1	0	x	Enabled
0	0	1	1	0	Enabled
0	0	1	1	1	Suspended
0	1	0	x	x	High-Z ²
0	1	1	0	x	Enabled
0	1	1	1	0	Suspended
0	1	1	1	1	Enabled
1	0	0	x	0	High-Z ²
1	0	1	0	0	Enabled
1	0	1	1	0	Enabled
1	1	0	x	0	High-Z ²
1	1	1	0	0	Enabled
1	1	1	1	0	Suspended
1	x	x	x	1	Suspended ¹

Note 1 : Global Shutdown

Note 2 : Hi-Z regardless of OEM bits

Programming the Device

I²C may be used to program the IDT5V19EE903.

– Device (slave) address = 7'b1101010

I²C Programming

The IDT5V19EE903 is programmed through an I²C-Bus serial interface, and is an I²C slave device. The read and write transfer formats are supported. The first byte of data after a write frame to the correct slave address is interpreted as the register address; this address auto-increments after each byte written or read.

The frame formats are shown in the following illustration.

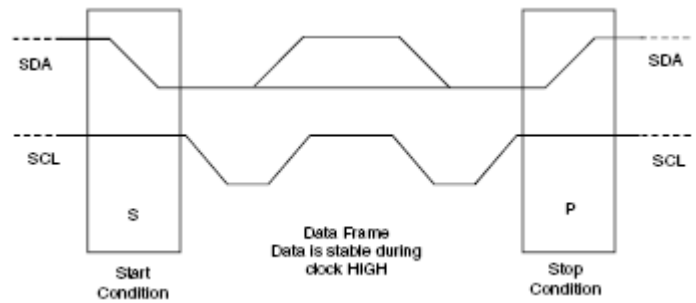

Framing

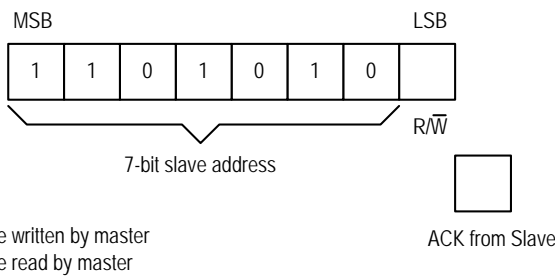

R/W
0 – Slave will be written by master
1 – Slave will be read by master

The first byte transmitted by the Master is the Slave Address followed by the R/W bit. The Slave acknowledges by sending a "1" bit.

First Byte Transmitted on I²C Bus

External I²C Interface Condition

KEY:

- From Master to Slave
- From Master to Slave, but can be omitted if followed by the correct sequence
Normally, data transfer is terminated by a STOP condition generated by the Master. However, if the Master still wishes to communicate on the bus, it can generate a separate START condition, and address another Slave address without first generating a STOP condition.
- From Slave to Master

SYMBOLS:

- ACK - Acknowledge (SDAT LOW)
- NACK – Not Acknowledge (SDAT HIGH)
- SR – Repeated Start Condition
- S – START Condition
- P – STOP Condition

Progwrite

S	Address	R/W	ACK	Command Code	ACK	Register	ACK	Data	ACK	P
	7-bits	0	1-bit	8-bits: xxxx xx00	1-bit	8-bits	1-bit	8-bits	1-bit	

Progwrite Command Frame

Writes can continue as long as a Stop condition is not sent and each byte will increment the register address.

Progreed

Note: If the expected read command is not from the next higher register to the previous read or write command, then set a known “read” register address prior to a read operation by issuing the following command:

S	Address	R/ \bar{W}	ACK	Command Code	ACK	Register	ACK	P
	7-bits	0	1-bit	8-bits: xxxx xx00	1-bit	8-bits	1-bit	

Prior to Progreed Command Set Register Address

The user can ignore the STOP condition above and use a repeated START condition instead, straight after the slave acknowledgement bit (i.e., followed by the Progreed command):

S	Address	R/ \bar{W}	ACK	ID Byte	ACK	Data_1	ACK	Data_2	ACK	Data_last	NACK	P
	7-bits	1	1-bit	8-bits	1-bit	8-bits	1-bit	8-bits	1-bit	8-bits	1-bit	

Progreed Command Frame

Progsave

S	Address	R/ \bar{W}	ACK	Command Code	ACK	P
	7-bits	0	1-bit	8-bits: xxxx xx01	1-bit	

Note:

PROGWRITE is for writing to the IDT5V19EE903 registers.

PROGREAD is for reading the IDT5V19EE903 registers.

PROGSAVE is for saving all the contents of the IDT5V19EE903 registers to the EEPROM.

PROGRESTORE is for loading the entire EEPROM contents to the IDT5V19EE903 registers.

Progrestore

S	Address	R/ \bar{W}	ACK	Command Code	ACK	P
	7-bits	0	1-bit	8-bits: xxxx xx10	1-bit	

EEPROM Interface

The IDT5V19EE903 can also store its configuration in an internal EEPROM. The contents of the device's internal programming registers can be saved to the EEPROM by issuing a save instruction (ProgSave) and can be loaded back to the internal programming registers by issuing a restore instruction (ProgRestore).

To initiate a save or restore using I²C, only two bytes are transferred. The Device Address is issued with the read/write bit set to “0”, followed by the appropriate command code. The save or restore instruction executes after the STOP condition is issued by the Master, during which time the IDT5V19EE903 will not generate Acknowledge bits. The IDT5V19EE903 will acknowledge the instructions after it has completed execution of them. During that time, the I²C bus should be interpreted as busy by all other users of the bus.

On power-up of the IDT5V19EE903, an automatic restore is performed to load the EEPROM contents into the internal programming registers. The IDT5V19EE903 will be ready to accept a programming instruction once it acknowledges its 7-bit I²C address.

I²C Bus DC Characteristics

Symbol	Parameter	Conditions	Min	Typ	Max	Unit
V _{IH}	Input HIGH Level		0.7xV _{DD}			V
V _{IL}	Input LOW Level				0.3xV _{DD}	V
V _{HYS}	Hysteresis of Inputs		0.05xV _{DD}			V
I _{IN}	Input Leakage Current				±1.0	µA
V _{OL}	Output LOW Voltage	I _{OL} = 3 mA			0.4	V

I²C Bus AC Characteristics for Standard Mode

Symbol	Parameter	Min	Typ	Max	Unit
F _{SCLK}	Serial Clock Frequency (SCL)	0		100	kHz
t _{BUF}	Bus free time between STOP and START	4.7			µs
t _{SU:START}	Setup Time, START	4.7			µs
t _{HD:START}	Hold Time, START	4			µs
t _{SU:DATA}	Setup Time, data input (SDA)	250			ns
t _{HD:DATA}	Hold Time, data input (SDA) ¹	0			µs
t _{OVD}	Output data valid from clock			3.45	µs
C _B	Capacitive Load for Each Bus Line			400	pF
t _R	Rise Time, data and clock (SDAT, SCLK)			1000	ns
t _F	Fall Time, data and clock (SDAT, SCLK)			300	ns
t _{HIGH}	HIGH Time, clock (SCLK)	4			µs
t _{LOW}	LOW Time, clock (SCLK)	4.7			µs
t _{SU:STOP}	Setup Time, STOP	4			µs

Note 1: A device must internally provide a hold time of at least 300 ns for the SDAT signal (referred to the V_{IH}(MIN) of the SCLK signal) to bridge the undefined region of the falling edge of SCLK.

I²C Bus AC Characteristics for Fast Mode

Symbol	Parameter	Min	Typ	Max	Unit
F _{SCLK}	Serial Clock Frequency (SCL)	0		400	kHz
t _{BUF}	Bus free time between STOP and START	1.3			μs
t _{SU:START}	Setup Time, START	0.6			μs
t _{HD:START}	Hold Time, START	0.6			μs
t _{SU:DATA}	Setup Time, data input (SDA)	100			ns
t _{HD:DATA}	Hold Time, data input (SDA) ¹	0			μs
t _{OVD}	Output data valid from clock			0.9	μs
C _B	Capacitive Load for Each Bus Line			400	pF
t _R	Rise Time, data and clock (SDA, SCL)	20 + 0.1xC _B		300	ns
t _F	Fall Time, data and clock (SDA, SCL)	20 + 0.1xC _B		300	ns
t _{HIGH}	HIGH Time, clock (SCL)	0.6			μs
t _{LOW}	LOW Time, clock (SCL)	1.3			μs
t _{SU:STOP}	Setup Time, STOP	0.6			μs

Note 1: A device must internally provide a hold time of at least 300 ns for the SDA signal (referred to the V_{IH}(MIN) of the SCL signal) to bridge the undefined region of the falling edge of SCL.

Absolute Maximum Ratings

Stresses above the ratings listed below can cause permanent damage to the IDT5V19EE903. These ratings, which are standard values for IDT commercially rated parts, are stress ratings only. Functional operation of the device at these or any other conditions above those indicated in the operational sections of the specifications is not implied. Exposure to absolute maximum rating conditions for extended periods can affect product reliability. Electrical parameters are guaranteed only over the recommended operating temperature range.

Symbol	Description	Min	Max	Unit
V_{DD}	Internal Power Supply Voltage	-0.5	+4.6	V
V_I	Input Voltage ¹	-0.5	+4.6	V
V_O	Output Voltage (not to exceed 4.6 V) ¹	-0.5	$V_{DD}+0.5$	V
T_J	Junction Temperature		150	°C
T_{STG}	Storage Temperature	-65	150	°C

1. Input negative and output voltage ratings may be exceeded if the input and output current ratings are observed.

Recommended Operation Conditions

Symbol	Parameter	Min	Typ	Max	Unit
V_{DD}	Power supply voltage for V_{DD} pins supporting core and outputs	3.135	3.3	3.465	V
V_{DDX}	Power supply voltage for crystal oscillator. Use filtered analog power supply if available.	3.135	3.3	3.465	V
AV_{DD}	Analog power supply voltage. Use filtered analog power supply if available.	3.135	3.3	3.465	V
T_A	Operating temperature, ambient	-40		+85	°C
C_{LOAD_OUT}	Maximum load capacitance			15	pF
F_{IN}	External reference crystal	8		50	MHz
	External reference clock CLKIN	1		200	
t_{PU}	Power up time for all V_{DD} s to reach minimum specified voltage (power ramps must be monotonic)	0.05		5	ms

Capacitance ($T_A = +25\text{ }^\circ\text{C}$, $f_{IN} = 1\text{ MHz}$, $V_{IN} = 0\text{V}$)

Symbol	Parameter	Min	Typ	Max	Unit
C_{IN}	Input Capacitance (VIN, CLKIN, CLKSEL, SD/OE, SDA, SCL, SEL[2:0])		3	7	pF
Pull-down Resistor	CLKIN, CLKSEL, SD/OE, SEL[2:0]		180		k Ω
Crystal Specifications					
XTAL_FREQ	Crystal frequency	8		50	MHz
XTAL_MIN	Minimum crystal load capacitance	3.5			pF
XTAL_MAX	Maximum crystal load capacitance			35.5	pF
XTAL_V _{PP}	Voltage swing (peak-to-peak, nominal)	1.5	2.3	3.2	V

DC Electrical Characteristics for 3.3-V LVTTTL ¹

Symbol	Parameter	Test Conditions	Min	Typ	Max	Unit
V_{OH}	Output HIGH Voltage		2.4		V_{DD}	V
V_{OL}	Output LOW Voltage				0.4	V
V_{IH}	Input HIGH Voltage		2			V
V_{IL}	Input LOW Voltage				0.8	V
I_{OZDD}	Output Leakage Current	3-state outputs. $V_O = V_{DD}$ or GND, $V_{DD} = 3.6\text{V}$			10	μA
VIN	VCXO Control Voltage		0		3.3	V

Note 1: See "Recommended Operating Conditions" table.

Power Supply Characteristics for PLLs and LVTTTL Outputs

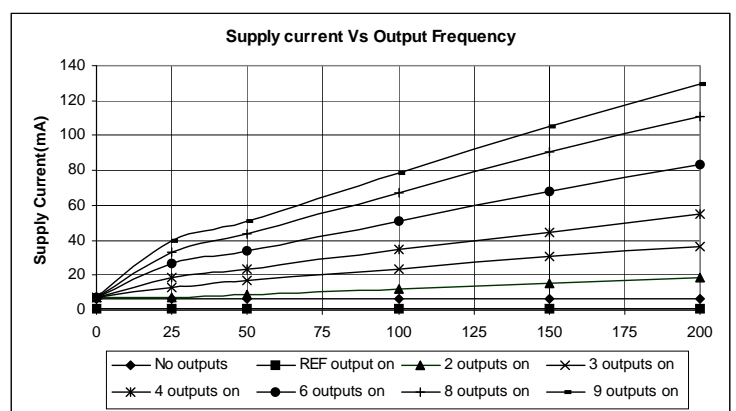
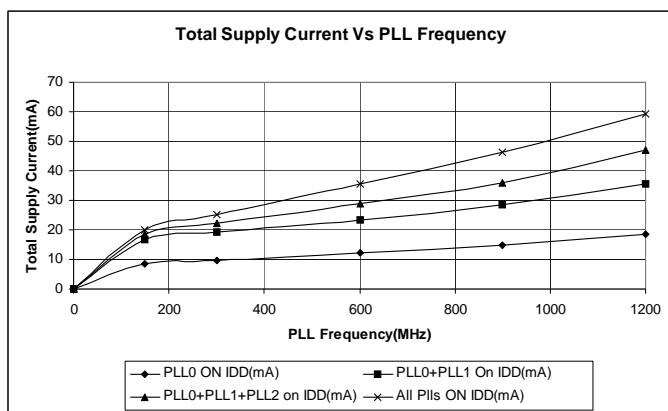

AC Timing Electrical Characteristics

(Spread Spectrum Generation = OFF)

Symbol	Parameter	Test Conditions	Min.	Typ.	Max.	Units
f_{IN}^1	Input Frequency	Input frequency limit (CLKIN)	1		200	MHz
		Input frequency limit (XIN/REF)	8		100	MHz
1 / t1	Output Frequency	Single ended clock output limit	0.001		200	MHz
f_{VCO}	VCO Frequency	VCO operating frequency range	100		1200	MHz
f_{PFD}	PFD Frequency	PFD operating frequency range	0.5 ¹		100	MHz
f_{BW}	Loop Bandwidth	Based on loop filter resistor and capacitor values	0.01		10	MHz
t2	Input Duty Cycle	Duty Cycle for input	40		60	%
t3	Output Duty Cycle	Measured at $V_{DD}/2$, all outputs except Reference output	45		55	%
		Measured at $V_{DD}/2$, Reference output	40		60	%
t4 ²	Slew Rate, SLEW[1:0] = 00	Single-ended 3.3V LVCMOS output clock rise and fall time, 20% to 80% of V_{DD} (Output Load = 5 pF)		3.5		V/ns
	Slew Rate, SLEW[1:0] = 01	Single-ended 3.3V LVCMOS output clock rise and fall time, 20% to 80% of V_{DD} (Output Load = 5 pF)		2.75		
	Slew Rate, SLEW[1:0] = 10	Single-ended 3.3V LVCMOS output clock rise and fall time, 20% to 80% of V_{DD} (Output Load = 5 pF)		2		
	Slew Rate, SLEW[1:0] = 11	Single-ended 3.3V LVCMOS output clock rise and fall time, 20% to 80% of V_{DD} (Output Load = 5 pF)		1.25		
t5	Clock Jitter	Peak-to-peak period jitter, 1PLL, multiple output frequencies switching		80	100	ps
		Peak-to-peak period jitter, all 4 PLLs on ³		200	270	ps
t8	Output Skew	Skew between output to output on the same bank			75	ps
t9 ⁴	Lock Time	PLL lock time from power-up		10	20	ms
t10 ⁵	Lock Time	PLL lock time from shutdown mode			2	ms
K_{VCXO}	VCXO Gain	$V_{IN} = V_{DD}/2 \pm 1V$		75	100	ppm/V
	Crystal Pullability ⁶	$0V \leq V_{IN} \leq 3.3V$	-100		100	ppm

1. Practical lower frequency is determined by loop filter settings.

2. A slew rate of 2.75V/ns or greater should be selected for output frequencies of 100MHz or higher.

3. Jitter measured with clock outputs of 27 MHz, 48 MHz, 24.576 MHz, 74.25 MHz and 25 MHz.

4. Includes loading the configuration bits from EEPROM to PLL registers. It does not include EEPROM programming/write time.

5. Actual PLL lock time depends on the loop configuration.

6. With a pullable crystal that conforms to IDT's specifications.

Spread Spectrum Generation Specifications

Symbol	Parameter	Description	Min	Typ	Max	Unit
f_{IN}^1	Input Frequency	Input Frequency Limit	1		400	MHz
f_{MOD}	Mod Frequency	Modulation Frequency		33	120	kHz
f_{SPREAD}	Spread Value	Amount of Spread Value (programmable) - Down Spread	-0.5		-4.0	% f_{OUT}
		Amount of Spread Value (programmable) - Center Spread	± 0.25		± 2.0	

1. Practical lower frequency is determined by loop filter settings.

Test Circuits and Conditions

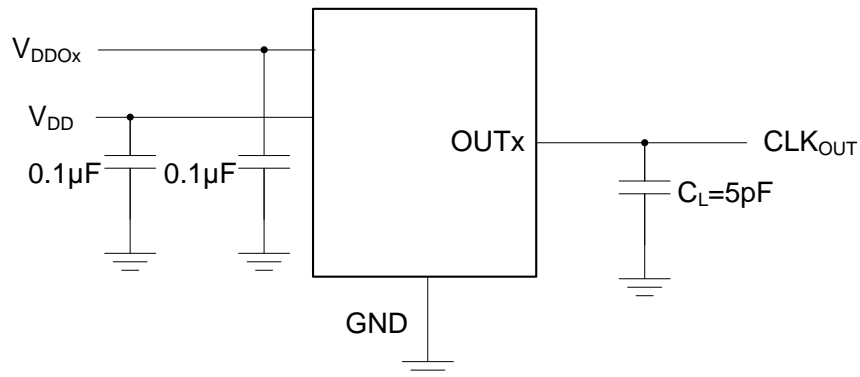

Test Circuits for DC Outputs

Programming Registers Table

Addr	Default Register Hex Value	Bit #								Description
		7	6	5	4	3	2	1	0	
0x00	00	Reserved							HW/SW	Hardware/Software Mode control HW/SW - 0=HW, 1=SW
0x01	00	Reserved				SEL[2:0]				SEL[2:0] - selects configuration in SW mode
0x02	02	SP	OE6	OE5	OE4	OE3	OE2	OE1	OE0	OEx=Output Power Suspend function for OUTx ('1'=OUTx will be suspended on SD/OE pin. Disable mode is defined by OEMx bits), '0'=outputs enabled and no association with OE pin (default).
0x03	02	Reserved	OS*[6:0]							OS*[6:0] - output suspend, active low. Overwrites OE setting.
0x04	0F	SH	Reserved			PLLS*[3:0]				PLLS*[3:0] - PLL Suspend, active low SH - shutdown/OE configuration
0x05	04	Reserved			XTCLKSEL					XTCLKSEL - crystal/clock select. 0=Crytal, 1=ICLK
0x06	00	Reserved		XDRV[1:0]		Reserved		Reserved		Crystal drive finetune XDRV[1:0] - crystal drive strength for VCXO
0x07	00	Reserved			XTAL[4:0]					XTAL[4:0] - crystal cap
0x08	00	GAIN[3:0]				OFFSET[3:0]				VCXO bits
0x09	00	Reserved								Reserved
0x0A	10	CZ0_CFG4	IP0[2:0]_CFG4			RZ0[3:0]_CFG4				PLL0 loop parameter
0x0B	10	CZ0_CFG5	IP0[2:0]_CFG5			RZ0[3:0]_CFG5				
0x0C	10	CZ0_CFG0	IP0[2:0]_CFG0			RZ0[3:0]_CFG0				
0x0D	10	CZ0_CFG1	IP0[2:0]_CFG1			RZ0[3:0]_CFG1				
0x0E	10	CZ0_CFG2	IP0[2:0]_CFG2			RZ0[3:0]_CFG2				
0x0F	10	CZ0_CFG3	IP0[2:0]_CFG3			RZ0[3:0]_CFG3				
0x10	00	Reserved	D0[6:0]_CFG0						PLL0 input divider and input sel D0[6:0] - 127 step Ref Div D0 = 0 means power down.	
0x11	00	Reserved	D0[6:0]_CFG1							
0x12	00	Reserved	D0[6:0]_CFG2							
0x13	00	Reserved	D0[6:0]_CFG3							
0x14	00	Reserved	D0[6:0]_CFG4							
0x15	00	Reserved	D0[6:0]_CFG5							
0x16	01	N0[7:0]_CFG4						N - Feedback Divider 2 - 4095 (values of "0" and "1" are not allowed) Total feedback with A, using provided calculation		
0x17	01	N0[7:0]_CFG5								
0x18	01	N0[7:0]_CFG0								
0x19	01	N0[7:0]_CFG1								
0x1A	01	N0[7:0]_CFG2								
0x1B	01	N0[7:0]_CFG3								
0x1C	00	A0[3:0]_CFG0			N0[11:8]_CFG0					
0x1D	00	A0[3:0]_CFG1			N0[11:8]_CFG1					
0x1E	00	A0[3:0]_CFG2			N0[11:8]_CFG2					
0x1F	00	A0[3:0]_CFG3			N0[11:8]_CFG3					
0x20	00	A0[3:0]_CFG4			N0[11:8]_CFG4					
0x21	00	A0[3:0]_CFG5			N0[11:8]_CFG5					

Addr	Default Register Hex Value	Bit #								Description
		7	6	5	4	3	2	1	0	
0x22	10	CZ1_CFG4	IP1[2:0]_CFG4		RZ1[3:0]_CFG4				PLL1 Loop Parameter	
0x23	10	CZ1_CFG5	IP1[2:0]_CFG5		RZ1[3:0]_CFG5					
0x24	10	CZ1_CFG0	IP1[2:0]_CFG0		RZ1[3:0]_CFG0					
0x25	10	CZ1_CFG1	IP1[2:0]_CFG1		RZ1[3:0]_CFG1					
0x26	10	CZ1_CFG2	IP1[2:0]_CFG2		RZ1[3:0]_CFG2					
0x27	10	CZ1_CFG3	IP1[2:0]_CFG3		RZ1[3:0]_CFG3					
0x28	00	Reserved	D1[6:0]_CFG0				PLL1 input divider and input sel D1[6:0] - 127 step Ref Div D1 = 0 means power down.			
0x29	00	Reserved	D1[6:0]_CFG1							
0x2A	00	Reserved	D1[6:0]_CFG2							
0x2B	00	Reserved	D1[6:0]_CFG3							
0x2C	00	Reserved	D1[6:0]_CFG4							
0x2D	00	Reserved	D1[6:0]_CFG5							
0x2E	01	N1[7:0]_CFG4				N - Feedback Divider 2 - 4095 (value of "0" is not allowed) Total feedback with A, using provided calculation				
0x2F	01	N1[7:0]_CFG5								
0x30	01	N1[7:0]_CFG0								
0x31	01	N1[7:0]_CFG1								
0x32	01	N1[7:0]_CFG2								
0x33	01	N1[7:0]_CFG3								
0x34	00	N3[11:8]_CFG0			N1[11:8]_CFG0				PLL3 Feedback Divider	
0x35	00	N3[11:8]_CFG1			N1[11:8]_CFG1					
0x36	00	N3[11:8]_CFG2			N1[11:8]_CFG2					
0x37	00	N3[11:8]_CFG3			N1[11:8]_CFG3					
0x38	00	N3[11:8]_CFG4			N1[11:8]_CFG4					
0x39	00	N3[11:8]_CFG5			N1[11:8]_CFG5					
0x3A	00	CZ2_CFG4	IP2[2:0]_CFG4		RZ2[3:0]_CFG4				PLL2 Loop Parameter	
0x3B	00	CZ2_CFG5	IP2[2:0]_CFG5		RZ2[3:0]_CFG5					
0x3C	00	CZ2_CFG0	IP2[2:0]_CFG0		RZ2[3:0]_CFG0					
0x3D	00	CZ2_CFG1	IP2[2:0]_CFG1		RZ2[3:0]_CFG1					
0x3E	00	CZ2_CFG2	IP2[2:0]_CFG2		RZ2[3:0]_CFG2					
0x3F	00	CZ2_CFG3	IP2[2:0]_CFG3		RZ2[3:0]_CFG3					
0x40	00	Reserved	D2[6:0]_CFG0				PLL2 Reference Divide and Input Select D2[6:0] - 127 step Ref Div D2 = 0 means power down.			
0x41	00	Reserved	D2[6:0]_CFG1							
0x42	00	Reserved	D2[6:0]_CFG2							
0x43	00	Reserved	D2[6:0]_CFG3							
0x44	00	Reserved	D2[6:0]_CFG4							
0x45	00	Reserved	D2[6:0]_CFG5							
0x46	01	N2[7:0]_CFG4				N2[7:0] - PLL2 Feedback Divider 2 - 4095 (value of "0" is not allowed). (See Addr 0x4C:0x51 for N2[15:8])				
0x47	01	N2[7:0]_CFG5								
0x48	01	N2[7:0]_CFG0								
0x49	01	N2[7:0]_CFG1								
0x4A	01	N2[7:0]_CFG2								
0x4B	01	N2[7:0]_CFG3								
0x4C	80	SSENB_CFG0	0	0	IP3[4]_CFG0	N2[11:8]_CFG0		N2[11:8] - PLL2 Feedback Divide PLL3 Spread Spectrum SSENB - Spread Spectrum Enable SSENB = 1 means ON IP3[4:0] - PLL3 Charge Pump Current.		
0x4D	80	SSENB_CFG1	0	0	IP3[4]_CFG1	N2[11:8]_CFG1				
0x4E	80	SSENB_CFG2	0	0	IP3[4]_CFG2	N2[11:8]_CFG2				
0x4F	80	SSENB_CFG3	0	0	IP3[4]_CFG3	N2[11:8]_CFG3				
0x50	80	SSENB_CFG4	0	0	IP3[4]_CFG4	N2[11:8]_CFG4				
0x51	80	SSENB_CFG5	0	0	IP3[4]_CFG5	N2[11:8]_CFG5				
0x52	XX ¹	Reserved								
0x53	XX ¹	Reserved								
0x54	XX ¹	Reserved								

Addr	Default Register Hex Value	Bit #								Description
		7	6	5	4	3	2	1	0	
0x55	XX ¹	Reserved								
0x56	00	IP3[3:0]_CFG4				RZ3[3:0]_CFG4				PLL3 Loop Parameter
0x57	00	IP3[3:0]_CFG5				RZ3[3:0]_CFG5				
0x58	00	IP3[3:0]_CFG0				RZ3[3:0]_CFG0				
0x59	00	IP3[3:0]_CFG1				RZ3[3:0]_CFG1				
0x5A	00	IP3[3:0]_CFG2				RZ3[3:0]_CFG2				
0x5B	00	IP3[3:0]_CFG3				RZ3[3:0]_CFG3				
0x5C	03	Reserved	D3[6:0]_CFG0							PLL3 Reference Divide and input sel D3[6:0] - 127 step Ref Div D3 = 0 means power down.
0x5D	03	Reserved	D3[6:0]_CFG1							
0x5E	03	Reserved	D3[6:0]_CFG2							
0x5F	03	Reserved	D3[6:0]_CFG3							
0x60	03	Reserved	D3[6:0]_CFG4							
0x61	03	Reserved	D3[6:0]_CFG5							
0x62	0C	N3[7:0]_CFG4								N - Feedback Divider 12 - 4095 (values of "0" through "11" are not allowed)
0x63	0C	N3[7:0]_CFG5								
0x64	0C	N3[7:0]_CFG0								
0x65	0C	N3[7:0]_CFG1								
0x66	0C	N3[7:0]_CFG2								
0x67	0C	N3[7:0]_CFG3								
0x68	00	SSVCO[7:0]_CFG0								SSVCO[7:0] - PLL3 Spread Spectrum Loop Feedback Counter See Addr 0x80:0x85 for SSVCO[15:8]
0x69	00	SSVCO[7:0]_CFG1								
0x6A	00	SSVCO[7:0]_CFG2								
0x6B	00	SSVCO[7:0]_CFG3								
0x6C	00	SSVCO[7:0]_CFG4								
0x6D	00	SSVCO[7:0]_CFG5								
0x6E	00	SS_D3[7:0]_CFG4								SS_D[7:0] - PLL3 Spread Spectrum Reference Divide
0x6F	00	SS_D3[7:0]_CFG5								
0x70	00	SS_D3[7:0]_CFG0								
0x71	00	SS_D3[7:0]_CFG1								
0x72	00	SS_D3[7:0]_CFG2								
0x73	00	SS_D3[7:0]_CFG3								
0x74	01	Reserved								Reserved
0x75	03	OEM0[1:0]	SLEW0[1:0]		INV0	Reserved	S1	S3		Output Controls S1=1 - OUT1/OUT2 are from DIV1/DIV2 respectively S1=0 - Both from DIV2 S3=1 - OUT3/OUT6 are from DIV3/DIV6 S3=0 - Both from DIV6 SLEW# OEM#-output enable mode x0 - tristated 01 - park low 11 - park high OEM0 controls OUT0 only
0x76	00	OEM1[1:0]	SLEW1[1:0]		INV1[1:0]		Reserved			Output Controls INV1 [CLK1, CLK2][0] - normal [1] - invert clock OEM1 controls OUT1/OUT2
0x77	00		SLEW2[1:0]					Reserved		
0x78	00	OEM3[1:0]	SLEW3[1:0]		INV3[1:0]		Reserved			OEM3 controls OUT3 and OUT6
0x79	00	OEM4[1:0]	SLEW4[1:0]		INV4[1:0]		Reserved			OEM4 controls OUT4 and OUT4b
0x7A	00	OEM5[1:0]	SLEW5[1:0]		INV5[1:0]		Reserved			OEM5 controls OUT5 and OUT5b
0x7B	00		SLEW6[1:0]					Reserved		

Addr	Default Register Hex Value	Bit #								Description
		7	6	5	4	3	2	1	0	
0x7C	XX ¹	Reserved								
0x7D	XX ¹	Reserved								
0x7E	XX ¹	Reserved								
0x7F	XX ¹	Reserved								
0x80	00	SSVCO[15:8]_CFG0								PLL3 Spread Spectrum Feedback Counter
0x81	00	SSVCO[15:8]_CFG1								
0x82	00	SSVCO[15:8]_CFG2								
0x83	00	SSVCO[15:8]_CFG3								
0x84	00	SSVCO[15:8]_CFG4								
0x85	00	SSVCO[15:8]_CFG5								
0x86	00	Reserved								
0x87	00	Reserved								
0x88	FF	PM1_CFG0	Q1[6:0]_CFG0							Output Divides for Q<>111111, PM=0 - Divide by 2 PM=1, (Q+2)*2 for Q=111111 PM=0, disable the output divider PM=1, bypass the output divide, (divide by 1)
0x89	FF	PM1_CFG1	Q1[6:0]_CFG1							
0x8A	FF	PM1_CFG2	Q1[6:0]_CFG2							
0x8B	FF	PM1_CFG3	Q1[6:0]_CFG3							
0x8C	FF	PM1_CFG4	Q1[6:0]_CFG4							
0x8D	FF	PM1_CFG5	Q1[6:0]_CFG5							
0x8E	7F	PM2_CFG4	Q2[6:0]_CFG4							
0x8F	7F	PM2_CFG5	Q2[6:0]_CFG5							
0x90	7F	PM2_CFG0	Q2[6:0]_CFG0							
0x91	7F	PM2_CFG1	Q2[6:0]_CFG1							
0x92	7F	PM2_CFG2	Q2[6:0]_CFG2							
0x93	7F	PM2_CFG3	Q2[6:0]_CFG3							
0x94	7F	PM3_CFG0	Q3[6:0]_CFG0							
0x95	7F	PM3_CFG1	Q3[6:0]_CFG1							
0x96	7F	PM3_CFG2	Q3[6:0]_CFG2							
0x97	7F	PM3_CFG3	Q3[6:0]_CFG3							
0x98	7F	PM3_CFG4	Q3[6:0]_CFG4							
0x99	7F	PM3_CFG5	Q3[6:0]_CFG5							
0x9A	7F	PM4_CFG4	Q4[6:0]_CFG4							
0x9B	7F	PM4_CFG5	Q4[6:0]_CFG5							
0x9C	7F	PM4_CFG0	Q4[6:0]_CFG0							
0x9D	7F	PM4_CFG1	Q4[6:0]_CFG1							
0x9E	7F	PM4_CFG2	Q4[6:0]_CFG2							
0x9F	7F	PM4_CFG3	Q4[6:0]_CFG3							
0xA0	7F	PM5_CFG0	Q5[6:0]_CFG0							
0xA1	7F	PM5_CFG1	Q5[6:0]_CFG1							
0xA2	7F	PM5_CFG2	Q5[6:0]_CFG2							
0xA3	7F	PM5_CFG3	Q5[6:0]_CFG3							
0xA4	7F	PM5_CFG4	Q5[6:0]_CFG4							
0xA5	7F	PM5_CFG5	Q5[6:0]_CFG5							
0xA6	7F	PM6_CFG4	Q6[6:0]_CFG4							
0xA7	7F	PM6_CFG5	Q6[6:0]_CFG5							
0xA8	7F	PM6_CFG0	Q6[6:0]_CFG0							
0xA9	7F	PM6_CFG1	Q6[6:0]_CFG1							
0xAA	7F	PM6_CFG2	Q6[6:0]_CFG2							
0xAB	7F	PM6_CFG3	Q6[6:0]_CFG3							

Addr	Default Register Hex Value	Bit #								Description
		7	6	5	4	3	2	1	0	
0xAC	00	TSSC[3:0]_CFG0				NSSC[3:0]_CFG0				PLL0 Spread Spectrum Control
0xAD	00	TSSC[3:0]_CFG1				NSSC[3:0]_CFG1				
0xAE	00	TSSC[3:0]_CFG2				NSSC[3:0]_CFG2				
0xAF	00	TSSC[3:0]_CFG3				NSSC[3:0]_CFG3				
0xB0	00	TSSC[3:0]_CFG4				NSSC[3:0]_CFG4				
0xB1	00	TSSC[3:0]_CFG5				NSSC[3:0]_CFG5				
0xB2	00	DITH_CFG4	X2_CFG4	SSOFFSET[5:0]_CFG4						
0xB3	00	DITH_CFG5	X2_CFG5	SSOFFSET[5:0]_CFG5						
0xB4	00	DITH_CFG0	X2_CFG0	SSOFFSET[5:0]_CFG0						
0xB5	00	DITH_CFG1	X2_CFG1	SSOFFSET[5:0]_CFG1						
0xB6	00	DITH_CFG2	X2_CFG2	SSOFFSET[5:0]_CFG2						
0xB7	00	DITH_CFG3	X2_CFG3	SSOFFSET[5:0]_CFG3						
0xB8	11	SD1[3:0]_CFG0				SD0[3:0]_CFG0				
0xB9	11	SD1[3:0]_CFG1				SD0[3:0]_CFG1				
0xBA	11	SD1[3:0]_CFG2				SD0[3:0]_CFG2				
0xBB	11	SD1[3:0]_CFG3				SD0[3:0]_CFG3				
0xBC	11	SD1[3:0]_CFG4				SD0[3:0]_CFG4				
0xBD	11	SD1[3:0]_CFG5				SD0[3:0]_CFG5				
0xBE	AE	SRC1[1:0]_CFG4		SRC0[1:0]_CFG4		PDPL3_CFG4	SM[1:0]_CFG4		PRIMSRC_CFG4	Output Divide Source Selection
0xBF	AE	SRC1[1:0]_CFG5		SRC0[1:0]_CFG5		PDPL3_CFG5	SM[1:0]_CFG5		PRIMSRC_CFG5	PRIMSRC - primary source - crystal or ICLOCK 0 = crystal/REFIN 1 = CLKIN
0xC0	AE	SRC1[1:0]_CFG0		SRC0[1:0]_CFG0		PDPL3_CFG0	SM[1:0]_CFG0		PRIMSRC_CFG0	SM = switch mode 0x = manual 10 = reserved 11 = auto-revertive
0xC1	AE	SRC1[1:0]_CFG1		SRC0[1:0]_CFG1		PDPL3_CFG1	SM[1:0]_CFG1		PRIMSRC_CFG1	PDPL3 - PLL3 shutdown 0 = normal 1 = shut down
0xC2	AE	SRC1[1:0]_CFG2		SRC0[1:0]_CFG2		PDPL3_CFG2	SM[1:0]_CFG2		PRIMSRC_CFG2	SRC = MUX control bit prior to DIV# SRC0[1:0] 00 - DIV1 01 - DIV3 10 - Reference input
0xC3	AE	SRC1[1:0]_CFG3		SRC0[1:0]_CFG3		PDPL3_CFG3	SM[1:0]_CFG3		PRIMSRC_CFG3	
0xC4	24	SRC4[0]_CFG0	SRC3[2:0]_CFG0			SRC2[2:0]_CFG0		SRC1[2]_CFG0		SRC1/SRC2/SRC3..SRC5 000 - DIV1 001 - DIV3 010 - Reference input 011 - Reserved 100 - PLL0 101 - PLL1 110 - PLL2 111 - PLL3
0xC5	24	SRC4[0]_CFG1	SRC3[2:0]_CFG1			SRC2[2:0]_CFG1		SRC1[2]_CFG1		
0xC6	24	SRC4[0]_CFG2	SRC3[2:0]_CFG2			SRC2[2:0]_CFG2		SRC1[2]_CFG2		
0xC7	24	SRC4[0]_CFG3	SRC3[2:0]_CFG3			SRC2[2:0]_CFG3		SRC1[2]_CFG3		
0xC8	24	SRC4[0]_CFG4	SRC3[2:0]_CFG4			SRC2[2:0]_CFG4		SRC1[2]_CFG4		
0xC9	24	SRC4[0]_CFG5	SRC3[2:0]_CFG5			SRC2[2:0]_CFG5		SRC1[2]_CFG5		
0xCA	49	SRC6[2:0]_CFG4			SRC5[2:0]_CFG4			SRC4[2:1]_CFG4		SRC6 000 - Reserved 001 - Reserved 010 - Reference input 011 - Reserved 100 - Reserved 101 - PLL1 110 - Reserved 111 - Reserved Quiet MUX
0xCB	49	SRC6[2:0]_CFG5			SRC5[2:0]_CFG5			SRC4[2:1]_CFG5		
0xCC	49	SRC6[2:0]_CFG0			SRC5[2:0]_CFG0			SRC4[2:1]_CFG0		
0xCD	49	SRC6[2:0]_CFG1			SRC5[2:0]_CFG1			SRC4[2:1]_CFG1		
0xCE	49	SRC6[2:0]_CFG2			SRC5[2:0]_CFG2			SRC4[2:1]_CFG2		
0xCF	49	SRC6[2:0]_CFG3			SRC5[2:0]_CFG3			SRC4[2:1]_CFG3		

Default Configuration: OUT1 = Reference Clock output, all other outputs turned off.

1. Memory bytes do not exist. Readback will be last value in shift register. If reading sequentially, value in 0x51 will be returned.

Marking Diagram (NLG32)

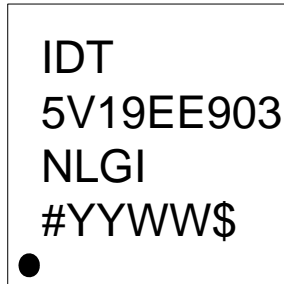

Marking Diagram (PGG28)

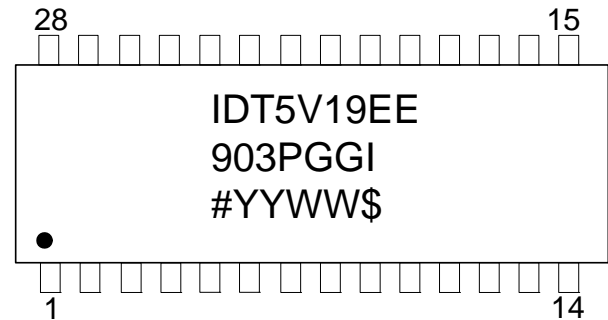

Notes:

1. “#” is the lot number.
2. YYWW is the last two digits of the year and week that the part was assembled.
3. “\$” is the assembly mark code.
4. “G” after the two-letter package code designates RoHS compliant package.
5. “I” at the end of part number indicates industrial temperature range.
6. Bottom marking: country of origin if not USA.

Thermal Characteristics 28-pin TSSOP

Parameter	Symbol	Conditions	Min.	Typ.	Max.	Units
Thermal Resistance Junction to Ambient	θ_{JA}	Still air		83		°C/W
	θ_{JA}	1 m/s air flow		75		°C/W
	θ_{JA}	3 m/s air flow		61		°C/W
Thermal Resistance Junction to Case	θ_{JC}			60		°C/W
Thermal Resistance Junction to Top of Case	Ψ_{JT}	Still air		4.5		°C/W

Thermal Characteristics 32-pin VFQFPN

Parameter	Symbol	Conditions	Min.	Typ.	Max.	Units
Thermal Resistance Junction to Ambient	θ_{JA}	Still air		34		°C/W
	θ_{JA}	1 m/s air flow		29		°C/W
	θ_{JA}	3 m/s air flow		27		°C/W
Thermal Resistance Junction to Case	θ_{JC}			32		°C/W

32-Pin QFN Landing Pattern

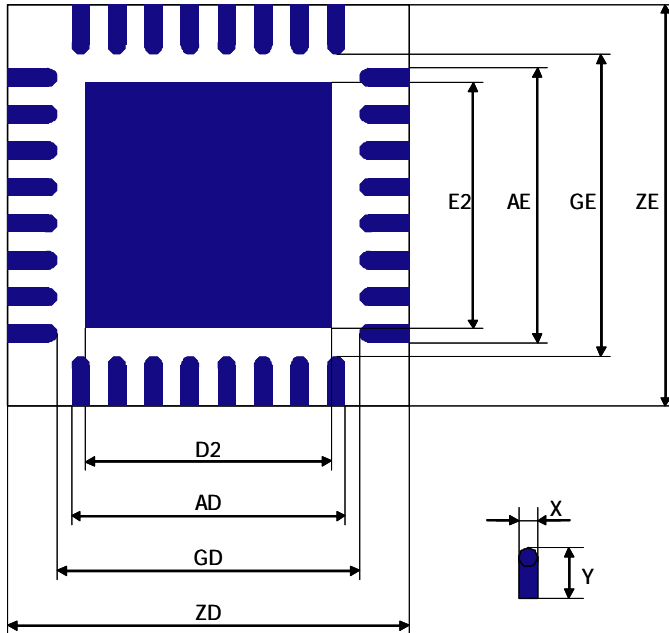

Dimensions	
X(max)	0.28
Yref	0.69
A(max)	3.78
G(min)	3.93
Z(max)	5.31
E2/D2(max)	3.63

Unit : mm

Package Outline and Package Dimensions (28-pin TSSOP, 173 Mil. Narrow Body)

Package dimensions are kept current with JEDEC Publication No. 95, MO-153

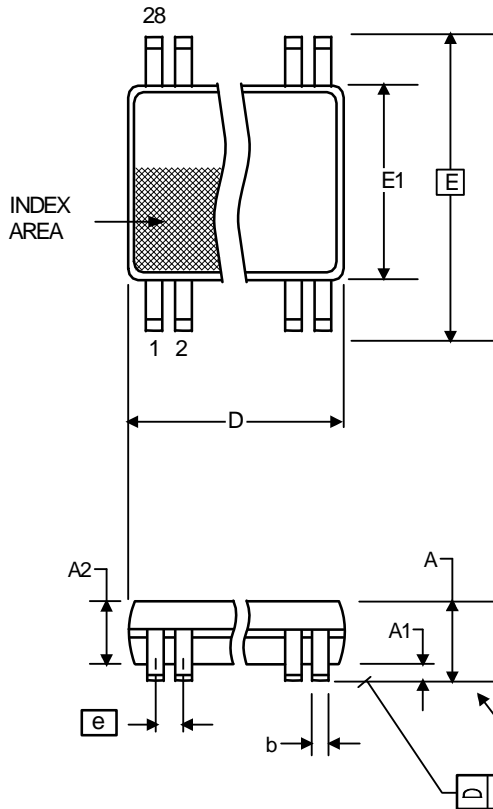

Symbol	Millimeters		Inches	
	Min	Max	Min	Max
A	--	1.20	--	0.047
A1	0.05	0.15	0.002	0.006
A2	0.80	1.05	0.032	0.041
b	0.19	0.30	0.007	0.012
C	0.09	0.20	0.0035	0.008
D	9.60	9.80	0.378	0.386
E	6.40 BASIC		0.252 BASIC	
E1	4.30	4.50	0.169	0.177
e	0.65 Basic		0.0256 Basic	
L	0.45	0.75	0.018	0.030
α	0°	8°	0°	8°
aaa	--	0.10	--	0.004

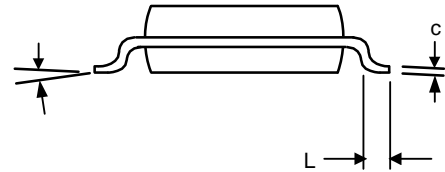

Revision History

Rev.	Date	Originator	Description of Change
A	4/22/09	R.Willner	Advance Information.
B	5/04/09	R.Willner	Identified VDDX (crystal oscillator power) and AVDD (analog power) on device.
C	6/04/09	R.Willner	Add default configurations, pull-down resistor values on input pins. Released Datasheet from Advanced Information.
D	06/10/09	R.Willner	Updates: crystal load specs; "Output Duty Cycle" specs; addresses 0x07, 0x02 and 0xBF in "Programming Registers" table.
E	08/26/09	R.Willner	Updated 32-pin VFQFPN thermal data.
F	10/05/09	R.Willner	Changed IP3[3:0] to IP3[4:0]; updated "Programming Registers Table".
G	02/23/10	R.Willner	Updated Recommended Operation Conditions to include Vddx and AVdd parameters.
H	04/22/11	R.Willner	Added 32-pin QFN Landing Pattern diagram.
J	07/07/11	A. Tsui	Updated package dimension drawing
K	04/18/12	R. Willner	1. Change description for SDAT and SCLK pins. 2. Add new footnotes to pin descriptions table 3. Added section "Crystal Clock Selection" 4. Added logic diagram and Truth table for "SD/OE Pin Function" section. 5. Corrected register readback values for 0x52~0x54 and 0x7C~0x7F. 6. Update to QFN package drawing - exposed thermal pad callout.
L	06/04/12	A. Tsui	1. Updated SD-OE pin description; from (Default is active HIGH) to (Default is active LOW) 2. Updated "OUTn" column in Truth Table with "High-Z" specs and added footnote 2, "High-Z regardless of OEM bits". 3. Updated "SD-OE Pin Function" section to reflect that SP is "0" changed from active HIGH to active LOW, and SP is "1" changed from active LOW to active HIGH.
M	06/18/12	R.Willner	Added Min/Max spread values to "Spread Spectrum Generation Specifications" table; fMOD - Max. 120kHz; Down Spread - Min. -0.5%, Max. -4.0%; Center Spread - Min. ±0.25%, Max. ±2.0%
N	09/24/12	R.Willner	Slew Rate (t4) Output Load test conditions were changed from 15pF to 5pF.

Innovate with IDT and accelerate your future networks. Contact:

www.IDT.com

For Sales

800-345-7015
408-284-8200
Fax: 408-284-2775

For Tech Support

www.idt.com/go/clockhelp

Corporate Headquarters

Integrated Device Technology, Inc.
www.idt.com

