

## 阅读申明

- 1.本站收集的数据手册和产品资料都来自互联网，版权归原作者所有。如读者和版权方有任何异议请及时告之，我们将妥善解决。
- 2.本站提供的中文数据手册是英文数据手册的中文翻译，其目的是协助用户阅读，该译文无法自动跟随原稿更新，同时也可能存在翻译上的不当。建议读者以英文原稿为参考以便获得更精准的信息。
- 3.本站提供的产品资料，来自厂商的技术支持或者使用者的心得体会等，其内容可能存在描述上的差异，建议读者做出适当判断。
- 4.如需与我们联系，请发邮件到marketing@iczoom.com，主题请标有“数据手册”字样。

## Read Statement

1. The datasheets and other product information on the site are all from network reference or other public materials, and the copyright belongs to the original author and original published source. If readers and copyright owners have any objections, please contact us and we will deal with it in a timely manner.
2. The Chinese datasheets provided on the website is a Chinese translation of the English datasheets. Its purpose is for reader's learning exchange only and do not involve commercial purposes. The translation cannot be automatically updated with the original manuscript, and there may also be improper translations. Readers are advised to use the English manuscript as a reference for more accurate information.
3. All product information provided on the website refer to solutions from manufacturers' technical support or users the contents may have differences in description, and readers are advised to take the original article as the standard.
4. If you have any questions, please contact us at marketing@iczoom.com and mark the subject with "Datasheets" .

### General Description

The 8745B-21 is a highly versatile 1:1 LVDS Clock Generator. The 8745B-21 has a fully integrated PLL and can be configured as zero delay buffer, multiplier or divider, and has an output frequency range of 31.25MHz to 700MHz. The Reference Divider, Feedback Divider and Output Divider are each programmable, thereby allowing for the following output-to-input frequency ratios: 8:1, 4:1, 2:1, 1:1, 1:2, 1:4, 1:8. The external feedback allows the device to achieve “zero delay” between the input clock and the output clock. The PLL\_SEL pin can be used to bypass the PLL for system test and debug purposes. In bypass mode, the reference clock is routed around the PLL and into the internal output dividers.

### Features

- One differential LVDS output designed to meet or exceed the requirements of ANSI TIA/EIA-644 One differential feedback output pair
- Differential CLK, nCLK input pair
- CLKx, nCLKx pair can accept the following differential input levels: LVPECL, LVDS, LVHSTL, HCSL, SSTL
- Output frequency range: 31.25MHz to 700MHz
- Input frequency range: 31.25MHz to 700MHz
- VCO range: 250MHz to 700MHz
- External feedback for “zero delay” clock regeneration with configurable frequencies
- Programmable dividers allow for the following output-to-input frequency ratios: 8:1, 4:1, 2:1, 1:1, 1:2, 1:4, 1:8
- Cycle-to-cycle jitter: 30ps (maximum)
- Output skew: 35ps (maximum)
- Static phase offset: 25ps ± 125ps
- Full 3.3V supply voltage
- 0°C to 70°C ambient operating temperature
- Available in lead-free (RoHS 6) package

### Block Diagram

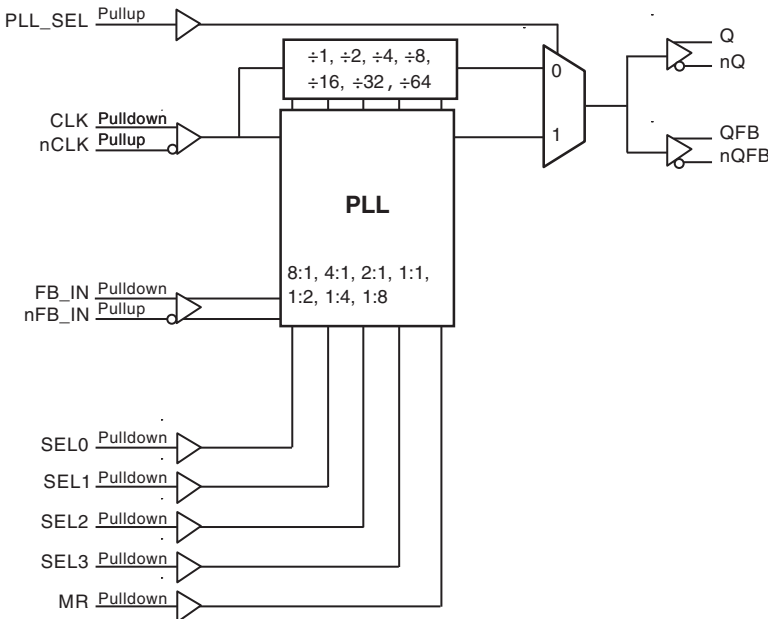

### Pin Assignment

CLK	1	20	SEL1
nCLK	2	19	SEL0
MR	3	18	V <sub>DD</sub>
nFB_IN	4	17	PLL_SEL
FB_IN	5	16	V <sub>DDA</sub>
SEL2	6	15	SEL3
V <sub>DDO</sub>	7	14	GND
nQFB	8	13	Q
QFB	9	12	nQ
GND	10	11	V <sub>DDO</sub>

**8745B-21**

**20-Lead SOIC**

**7.5mm x 12.8mm x 2.3mm package body**

**M Package**

**Top View**

**Table 1. Pin Descriptions**

Number	Name	Type		Description
1	CLK	Input	Pulldown	Non-inverting differential clock input.
2	nCLK	Input	Pullup	Inverting differential clock input.
3	MR	Input	Pulldown	Active HIGH Master Reset. When logic HIGH, the internal dividers are reset causing the true output Q to go low and the inverted output nQ to go high. When logic LOW, the internal dividers and the outputs are enabled. LVCMOS / LVTTTL interface levels.
4	nFBIN	Input	Pullup	Inverting differential feedback input to phase detector for regenerating clocks with "Zero Delay."
5	FBIN	Input	Pulldown	Non-inverted differential feedback input to phase detector for regenerating clocks with "Zero Delay."
6, 15, 19, 20	SEL2, SEL3, SEL0 SEL1	Input	Pulldown	Determines output divider values in Table 3. LVCMOS / LVTTTL interface levels.
7, 11	V <sub>DDO</sub>	Power		Output supply pins.
8, 9	nQFB/QFB	Output		Differential feedback output pair. LVDS interface levels.
10, 14	GND	Power		Power supply ground.
12, 13	nQ/Q	Output		Differential output pair. LVDS interface levels.
16	V <sub>DDA</sub>	Power		Analog supply pin.
17	PLL_SEL	Input	Pullup	PLL select. Selects between the PLL and reference clock as the input to the dividers. When LOW, selects reference clock. LVCMOS/LVTTTL interface levels.
18	V <sub>DD</sub>	Power		Core supply pin.

NOTE: *Pullup* and *Pulldown* refer to internal input resistors. See Table 2, *Pin Characteristics*, for typical values.

**Table 2. Pin Characteristics**

Symbol	Parameter	Test Conditions	Minimum	Typical	Maximum	Units
C <sub>IN</sub>	Input Capacitance			4		pF
R <sub>PULLUP</sub>	Input Pullup Resistor			51		kΩ
R <sub>PULLDOWN</sub>	Input Pulldown Resistor			51		kΩ

## Function Tables

Table 3A. Control Input Function Table

Inputs					Outputs PLL_SEL = 1 PLL Enable Mode
SEL3	SEL2	SEL1	SEL0	Reference Frequency Range (MHz)*	Q, nQ
0	0	0	0	250 - 700	÷1
0	0	0	1	125 - 350	÷1
0	0	1	0	62.5 - 175	÷1
0	0	1	1	31.25 - 87.5	÷1
0	1	0	0	250 - 700	÷2
0	1	0	1	125 - 350	÷2
0	1	1	0	62.5 - 175	÷2
0	1	1	1	250 - 700	÷4
1	0	0	0	125 - 350	÷4
1	0	0	1	250 - 700	÷8
1	0	1	0	125 - 350	x2
1	0	1	1	62.5 - 175	x2
1	1	0	0	31.25 - 87.5	x2
1	1	0	1	62.5 - 175	x4
1	1	1	0	31.25 - 87.5	x4
1	1	1	1	31.25 - 87.5	x8

\*NOTE: VCO frequency range for all configurations above is 250MHz to 700MHz.

**Table 3B. PLL Bypass Function Table**

Inputs				Outputs PLL_SEL = 0 PLL Bypass Mode
SEL3	SEL2	SEL1	SEL0	Q, nQ
0	0	0	0	÷4
0	0	0	1	÷4
0	0	1	0	÷4
0	0	1	1	÷8
0	1	0	0	÷8
0	1	0	1	÷8
0	1	1	0	÷16
0	1	1	1	÷16
1	0	0	0	÷32
1	0	0	1	÷64
1	0	1	0	÷2
1	0	1	1	÷2
1	1	0	0	÷4
1	1	0	1	÷1
1	1	1	0	÷2
1	1	1	1	÷1

## Absolute Maximum Ratings

NOTE: Stresses beyond those listed under *Absolute Maximum Ratings* may cause permanent damage to the device. These ratings are stress specifications only. Functional operation of product at these conditions or any conditions beyond those listed in the *DC Characteristics* or *AC Characteristics* is not implied. Exposure to absolute maximum rating conditions for extended periods may affect product reliability.

Item	Rating
Supply Voltage, $V_{DD}$	4.6V
Inputs, $V_I$	-0.5V to $V_{DD} + 0.5V$
Outputs, $I_O$ Continuous Current Surge Current	10mA 15mA
Package Thermal Impedance, $\theta_{JA}$	46.2°C/W (0 lfpm)
Storage Temperature, $T_{STG}$	-65°C to 150°C

## DC Electrical Characteristics

**Table 4A. LVDS Power Supply DC Characteristics,  $V_{DD} = V_{DDO} = 3.3V \pm 5\%$ ,  $T_A = 0^\circ C$  to  $70^\circ C$**

Symbol	Parameter	Test Conditions	Minimum	Typical	Maximum	Units
$V_{DD}$	Core Supply Voltage		3.135	3.3	3.465	V
$V_{DDA}$	Analog Supply Voltage		3.135	3.3	3.465	V
$V_{DDO}$	Output Supply Voltage		3.135	3.3	3.465	V
$I_{DD}$	Power Supply Current				125	mA
$I_{DDA}$	Analog Supply Current				17	mA
$I_{DDO}$	Output Supply Current				59	mA

**Table 4B. LVCMOS/LVTTL DC Characteristics,  $V_{DD} = V_{DDO} = 3.3V \pm 5\%$ ,  $T_A = 0^\circ C$  to  $70^\circ C$**

Symbol	Parameter	Test Conditions	Minimum	Typical	Maximum	Units
$V_{IH}$	Input High Voltage		2		$V_{DD} + 0.3$	V
$V_{IL}$	Input Low Voltage		-0.3		0.8	V
$I_{IH}$	Input High Current	SEL[0:3], MR	$V_{DD} = V_{IN} = 3.465V$		150	$\mu A$
		PLL_SEL	$V_{DD} = V_{IN} = 3.465V$		5	$\mu A$
$I_{IL}$	Input Low Current	SEL[0:3], MR	$V_{DD} = 3.465V, V_{IN} = 0V$	-5		$\mu A$
		PLL_SEL	$V_{DD} = 3.465V, V_{IN} = 0V$	-150		$\mu A$

**Table 4C. Differential DC Characteristics,  $V_{DD} = V_{DDO} = 3.3V \pm 5\%$ ,  $T_A = 0^\circ C$  to  $70^\circ C$** 

Symbol	Parameter		Test Conditions	Minimum	Typical	Maximum	Units
$I_{IH}$	Input High Current	CLK, FB_IN	$V_{DD} = V_{IN} = 3.465V$			150	$\mu A$
		nCLK, nFB_IN	$V_{DD} = V_{IN} = 3.465V$			5	$\mu A$
$I_{IL}$	Input Low Current	CLK, FB_IN	$V_{DD} = 3.465V,$ $V_{IN} = 0V$	-5			$\mu A$
		nCLK, nFB_IN	$V_{DD} = 3.465V,$ $V_{IN} = 0V$	-150			$\mu A$
$V_{PP}$	Peak-to-Peak Voltage; NOTE 1			0.15		1.3	V
$V_{CMR}$	Common Mode Input Voltage; NOTE 1, 2			GND + 0.5		$V_{DD} - 0.85$	V

 NOTE 1:  $V_{IL}$  should not be less than -0.3V.

 NOTE 2: Common mode input voltage is defined as  $V_{IH}$ .

**Table 4D. LVDS DC Characteristics,  $V_{DD} = V_{DDO} = 3.3V \pm 5\%$ ,  $T_A = 0^\circ C$  to  $70^\circ C$** 

Symbol	Parameter	Test Conditions	Minimum	Typical	Maximum	Units
$V_{OD}$	Differential Output Voltage		320	440	550	mV
$\Delta V_{OD}$	$V_{OD}$ Magnitude Change			0	50	mV
$V_{OS}$	Offset Voltage		1.05	1.2	1.35	V
$\Delta V_{OS}$	$V_{OS}$ Magnitude Change				25	mV

**Table 5. Input Frequency Characteristics,  $V_{DD} = V_{DDO} = 3.3V \pm 5\%$ ,  $T_A = 0^\circ C$  to  $70^\circ C$** 

Symbol	Parameter		Test Conditions	Minimum	Typical	Maximum	Units
$F_{IN}$	Input Frequency	CLK, nCLK	PLL_SEL = 1	31.25		700	$\mu A$
			PLL_SEL = 0			700	V

## AC Electrical Characteristics

**Table 6. AC Characteristics,  $V_{DD} = V_{DDO} = 3.3V \pm 5\%$ ,  $T_A = 0^\circ\text{C}$  to  $70^\circ\text{C}$**

Symbol	Parameter	Test Conditions	Minimum	Typical	Maximum	Units
$f_{MAX}$	Output Frequency				700	MHz
$t_{PD}$	Propagation Delay; NOTE 1	PLL_SEL = 0V, $f \leq 700\text{MHz}$	3.1	3.4	4.0	ns
$t_{sk}(\emptyset)$	Static Phase Offset; NOTE 2, 5	PLL_SEL = 3.3V	-100	25	150	ps
$t_{sk}(o)$	Output Skew; NOTE 3, 5				35	ps
$f_{jit}(cc)$	Cycle-to-Cycle Jitter; NOTE 5, 6				30	ps
$f_{jit}(\theta)$	Phase Jitter; NOTE 4, 5, 6				$\pm 52$	ps
$t_L$	PLL Lock Time				1	ms
$t_R / t_F$	Output Rise/Fall Time; NOTE 7	20% to 80%	200		700	ps
odc	Output Duty Cycle		46	50	54	%

NOTE: Electrical parameters are guaranteed over the specified ambient operating temperature range, which is established when the device is mounted in a test socket with maintained transverse airflow greater than 500 lpm. The device will meet specifications after thermal equilibrium has been reached under these conditions.

NOTE 1: Measured from the differential input crossing point to the differential output crossing point.

NOTE 2: Defined as the time difference between the input reference clock and the averaged feedback input signal across all conditions, when the PLL is locked and the input reference frequency is stable.

NOTE 3: Defined as skew between outputs at the same supply voltage and with equal load conditions. Measured at the output differential cross points.

NOTE 4: Phase jitter is dependent on the input source used.

NOTE 5: This parameter is defined in accordance with JEDEC Standard 65.

NOTE 6: Characterized at VCO frequency of 622MHz.

NOTE 7: Measured from the 20% to 80% points. Guaranteed by characterization. Not production tested.



## Parameter Measurement Information

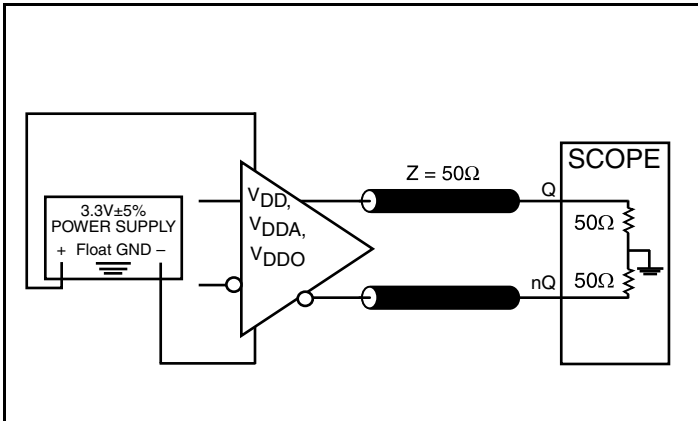

3.3V LVDS Output Load AC Test Circuit

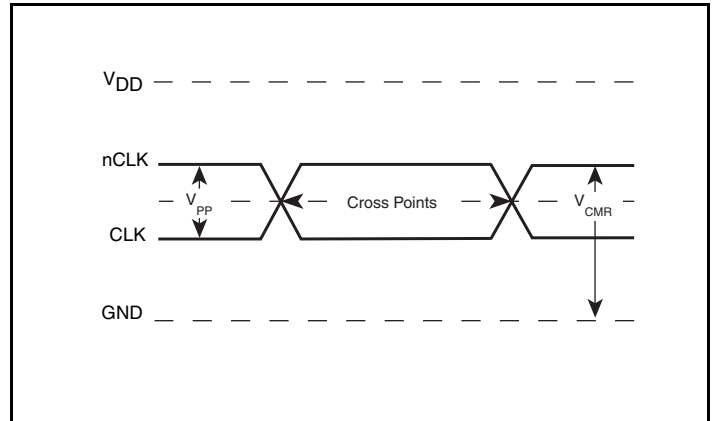

Differential Input Level

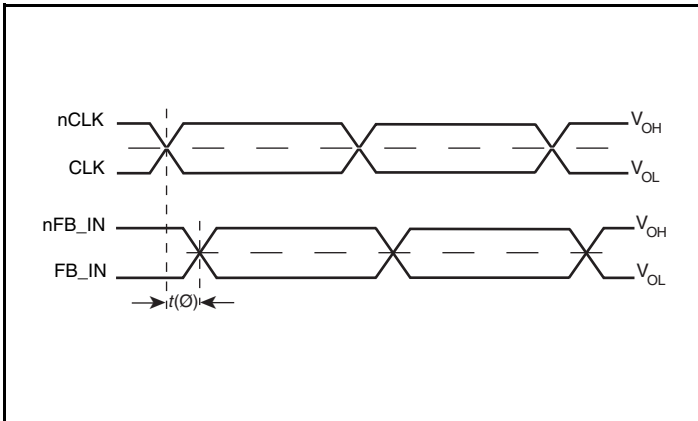

Phase Jitter and Static Phase Offset

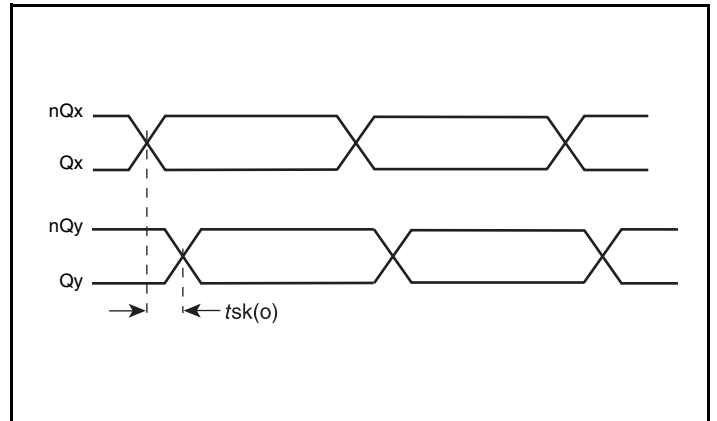

Output Skew

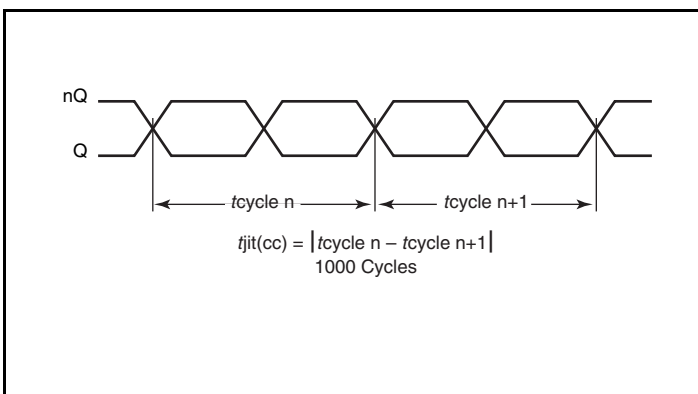

Cycle-to-Cycle Jitter

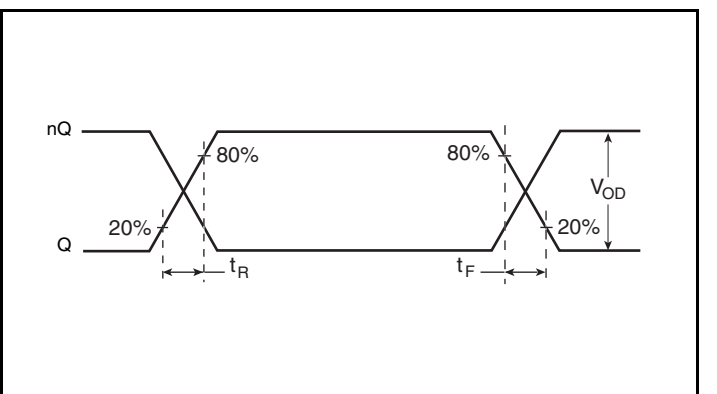

Output Rise/Fall Time

## Parameter Measurement Information, continued

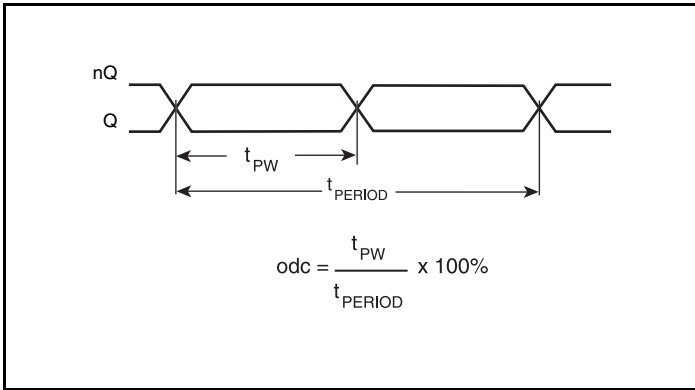

**Output Duty Cycle**

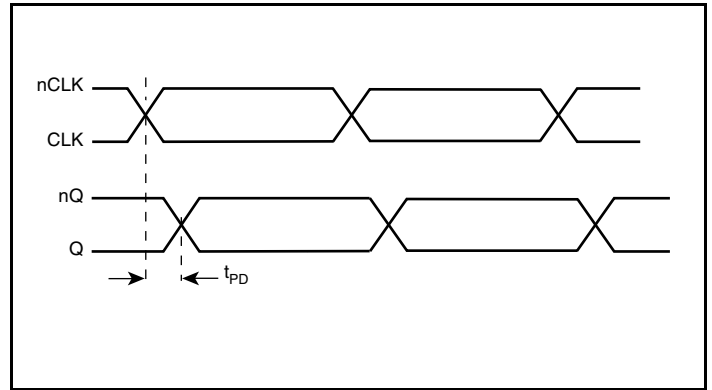

**Propagation Delay**

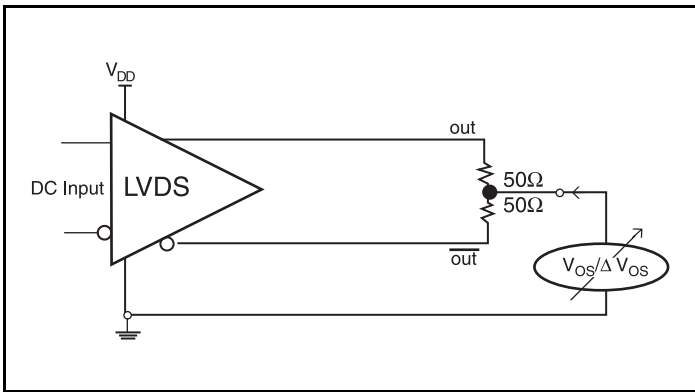

**Offset Voltage Setup**

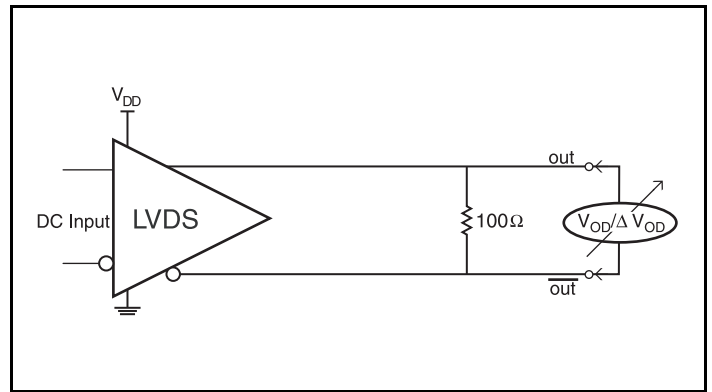

**Differential Output Voltage Setup**

## Application Information

### Power Supply Filtering Technique

As in any high speed analog circuitry, the power supply pins are vulnerable to random noise. To achieve optimum jitter performance, power supply isolation is required. The 8745B-21 provides separate power supplies to isolate any high switching noise from the outputs to the internal PLL.  $V_{DD}$ ,  $V_{DDA}$  and  $V_{DDO}$  should be individually connected to the power supply plane through vias, and  $0.01\mu\text{F}$  bypass capacitors should be used for each pin. *Figure 1* illustrates this for a generic  $V_{DD}$  pin and also shows that  $V_{DDA}$  requires that an additional  $10\Omega$  resistor along with a  $10\mu\text{F}$  bypass capacitor be connected to the  $V_{DDA}$  pin.

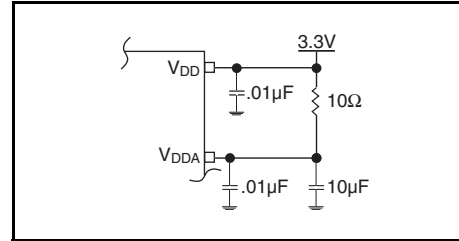

**Figure 1. Power Supply Filtering**

### Wiring the Differential Input to Accept Single Ended Levels

*Figure 2* shows how the differential input can be wired to accept single ended levels. The reference voltage  $V_{REF} = V_{DD}/2$  is generated by the bias resistors  $R1$ ,  $R2$  and  $C1$ . This bias circuit should be located as close as possible to the input pin. The ratio of  $R1$  and  $R2$  might need to be adjusted to position the  $V_{REF}$  in the center of the input voltage swing. For example, if the input clock swing is only  $2.5\text{V}$  and  $V_{DD} = 3.3\text{V}$ ,  $V_{REF}$  should be  $1.25\text{V}$  and  $R2/R1 = 0.609$ .

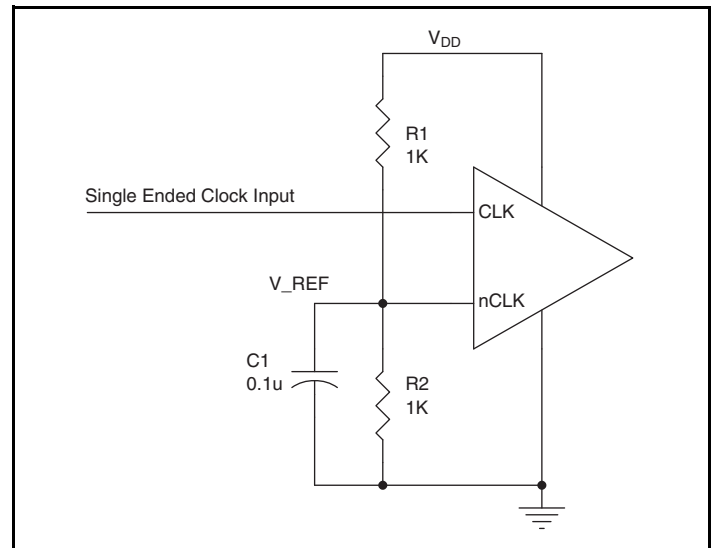
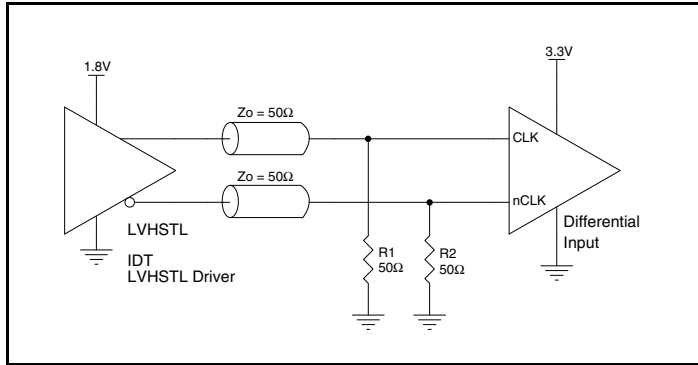

**Figure 2. Single-Ended Signal Driving Differential Input**

### Differential Clock Input Interface

The CLK /nCLK accepts LVDS, LVPECL, LVHSTL, SSTL, HCSL and other differential signals. Both signals must meet the  $V_{PP}$  and  $V_{CMR}$  input requirements. Figures 3A to 3F show interface examples for the CLK/nCLK input driven by the most common driver types. The input interfaces suggested here are examples only. Please consult with the

vendor of the driver component to confirm the driver termination requirements. For example, in Figure 3A, the input termination applies for IDT open emitter LVHSTL drivers. If you are using an LVHSTL driver from another vendor, use their termination recommendation.



**3A. CLK/nCLK Input Driven by an IDT Open Emitter LVHSTL Driver**

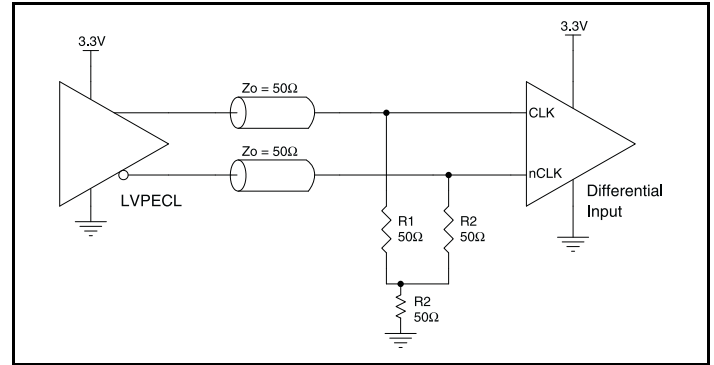

**Figure 3B. CLK/nCLK Input Driven by a 3.3V LVPECL Driver**

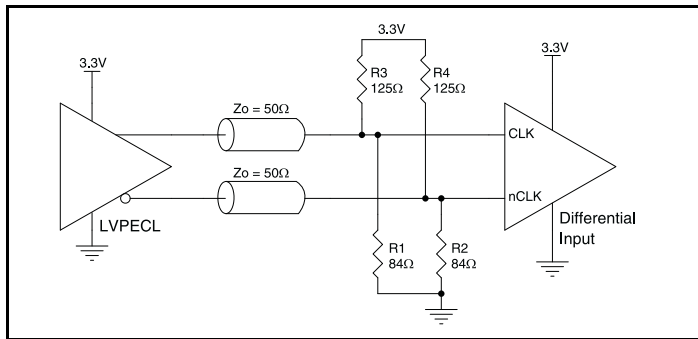

**Figure 3C. CLK/nCLK Input Driven by a 3.3V LVPECL Driver**

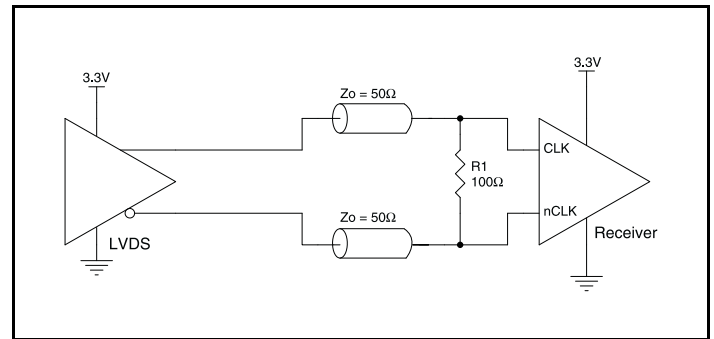

**Figure 3D. CLK/nCLK Input Driven by a 3.3V LVDS Driver**

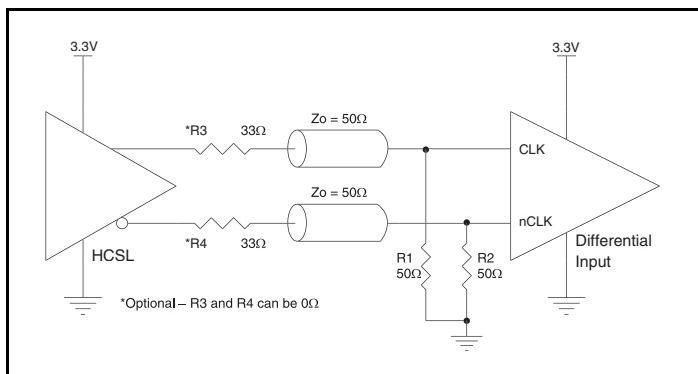

**Figure 3E. CLK/nCLK Input Driven by a 3.3V HCSL Driver**

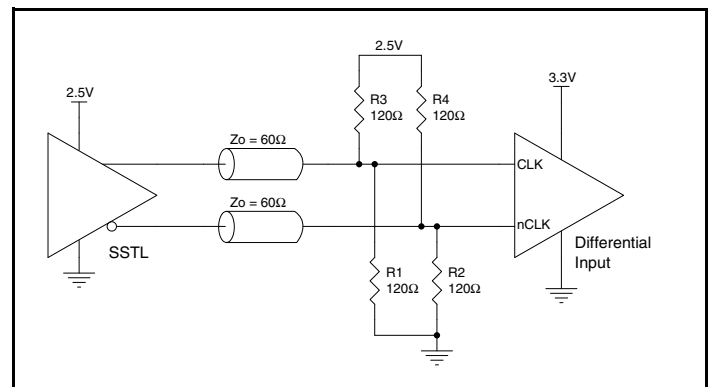

**Figure 3F. CLK/nCLK Input Driven by a 2.5V SSTL Driver**

## Recommendations for Unused Input and Output Pins

### Inputs:

#### LVC MOS Control Pins:

All control pins have internal pull-ups or pull-downs; additional resistance is not required but can be added for additional protection. A  $1\text{k}\Omega$  resistor can be used.

#### CLK/nCLK Input

For applications not requiring the use of the differential input, both CLK and nCLK can be left floating. Though not required, but for additional protection, a  $1\text{k}\Omega$  resistor can be tied from CLK to ground.

### Outputs:

#### LVDS Output

All unused LVDS output pairs can be either left floating or terminated with  $100\Omega$  across. If they are left floating, we recommend that there is no trace attached.

## 3.3V LVDS Driver Termination

A general LVDS interface is shown in *Figure 4*. In a  $100\Omega$  differential transmission line environment, LVDS drivers require a matched load termination of  $100\Omega$  across near the receiver input. For a multiple

LVDS outputs buffer, if only partial outputs are used, it is recommended to terminate the unused outputs.

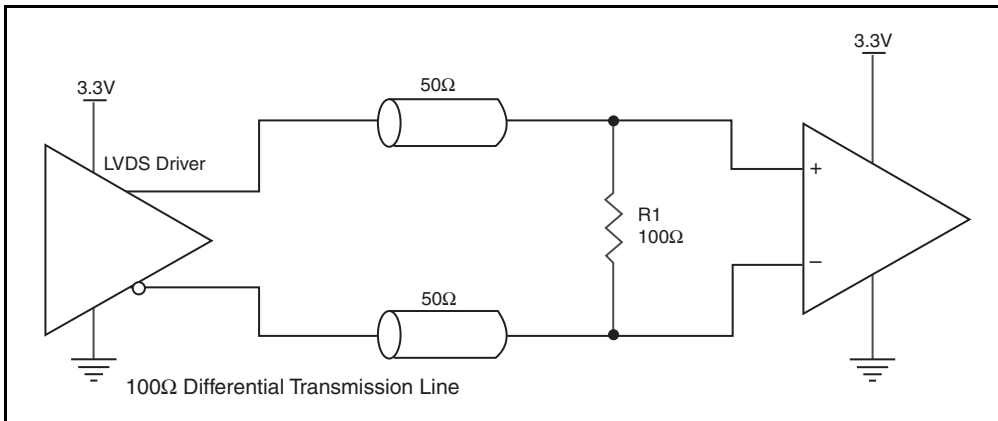
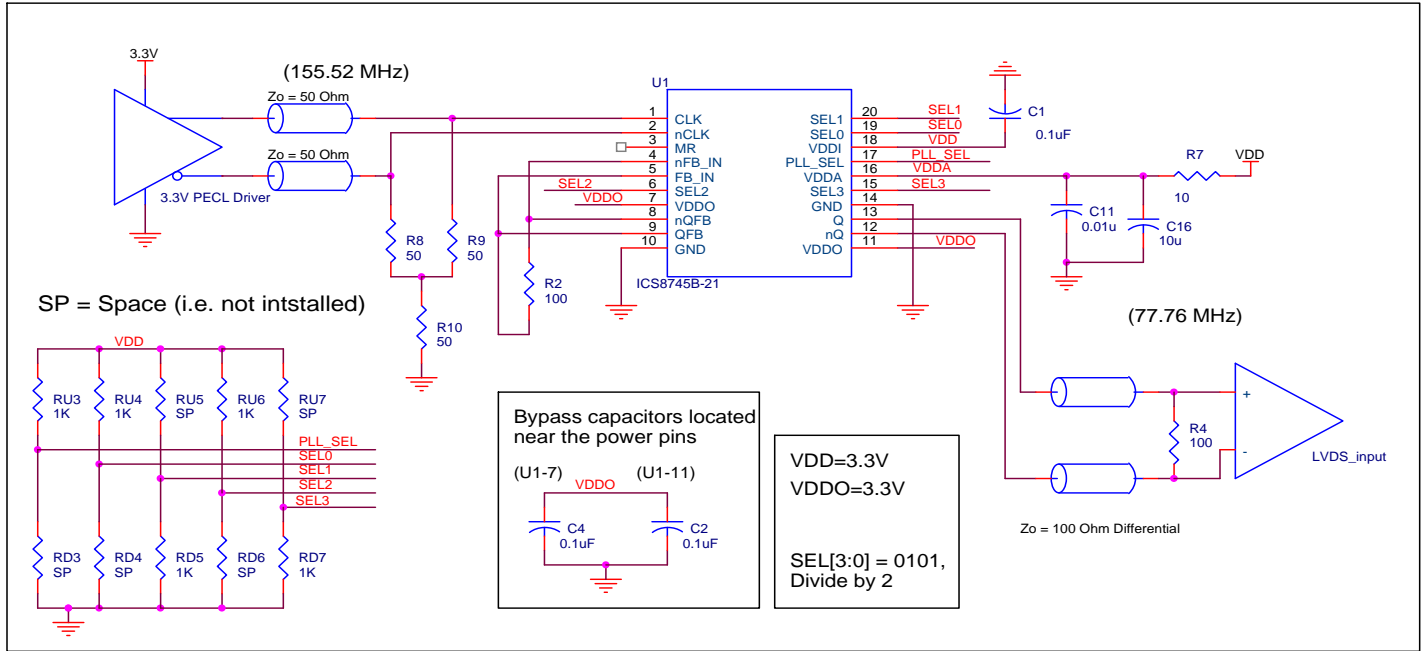

**Figure 4. Typical LVDS Driver Termination**

### Schematic Example

The schematic of the 8745B-21 layout example is shown in *Figure 5A*. The 8745B-21 recommended PCB board layout for this example is shown in *Figure 5B*. This layout example is used as a general

guideline. The layout in the actual system will depend on the selected component types, the density of the components, the density of the traces, and the stack up of the P.C. board.



**Figure 5A. 8745B-21 LVDS Zero Delay Buffer Schematic Example**

The following component footprints are used in this layout example.

All the resistors and capacitors are size 0603.

**Power and Grounding**

Place the decoupling capacitors as close as possible to the power pins. If space allows, placement of the decoupling capacitor on the component side is preferred. This can reduce unwanted inductance between the decoupling capacitor and the power pin caused by the via.

Maximize the power and ground pad sizes and number of vias capacitors. This can reduce the inductance between the power and ground planes and the component power and ground pins.

The RC filter consisting of R7, C11, and C16 should be placed as close to the V<sub>DDA</sub> pin as possible.

**Clock Traces and Termination**

Poor signal integrity can degrade the system performance or cause system failure. In synchronous high-speed digital systems, the clock signal is less tolerant to poor signal integrity than other signals. Any ringing on the rising or falling edge or excessive ring back can cause system failure. The shape of the trace and the trace delay might be

restricted by the available space on the board and the component location. While routing the traces, the clock signal traces should be routed first and should be locked prior to routing other signal traces.

- The differential 50Ω output traces should have the same length.
- Avoid sharp angles on the clock trace. Sharp angle turns cause the characteristic impedance to change on the transmission lines.
- Keep the clock traces on the same layer. Whenever possible, avoid placing vias on the clock traces. Placement of vias on the traces can affect the trace characteristic impedance and hence degrade signal integrity.
- To prevent cross talk, avoid routing other signal traces in parallel with the clock traces. If running parallel traces is unavoidable, allow a separation of at least three trace widths between the differential clock trace and the other signal trace.
- Make sure no other signal traces are routed between the clock trace pair.
- The matching termination resistors should be located as close to the receiver input pins as possible.

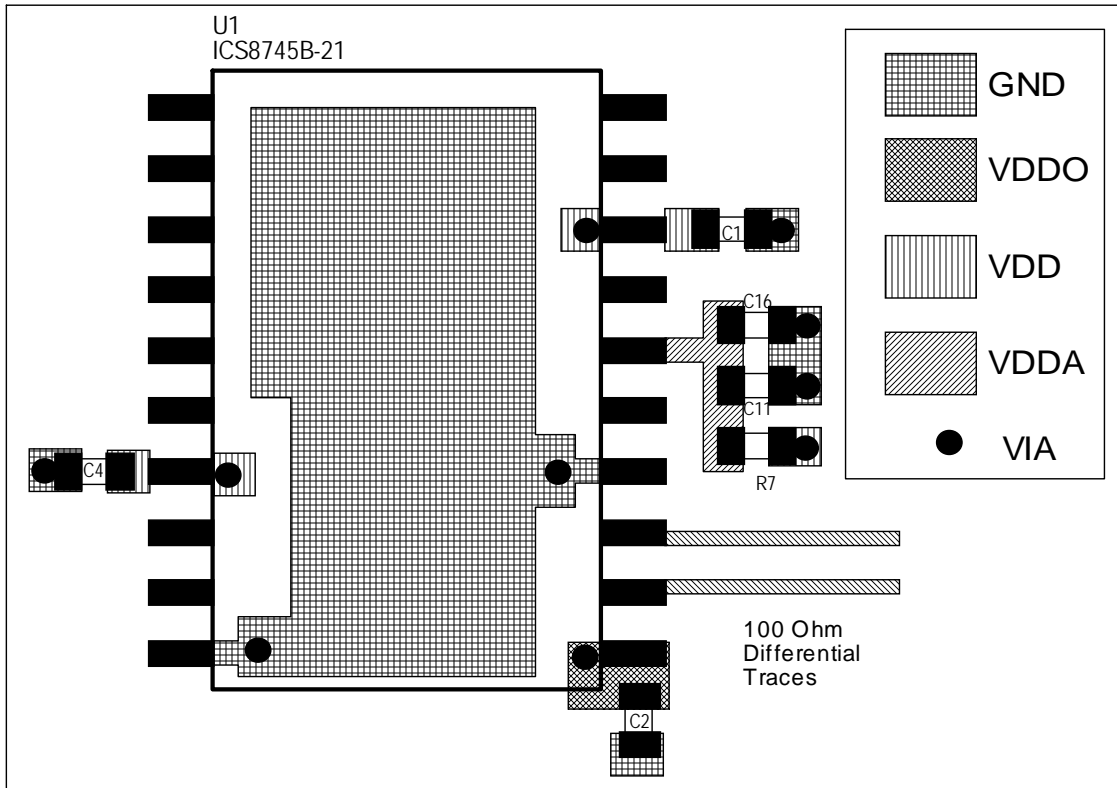

Figure 5B. PCB Board Layout for 8745B-21

## Power Considerations

This section provides information on power dissipation and junction temperature for the 8745B-21. Equations and example calculations are also provided.

### 1. Power Dissipation.

The total power dissipation for the 8745B-21 is the sum of the core power plus the analog power plus the power dissipated in the load(s). The following is the power dissipation for  $V_{DD} = 3.3V + 5\% = 3.465V$ , which gives worst case results.

NOTE: Please refer to Section 3 for details on calculating power dissipated in the load.

- Power (core)<sub>MAX</sub> =  $V_{DD\_MAX} * (I_{DD\_MAX} + I_{DDA\_MAX}) = 3.465V * (125mA + 17mA) = 492mW$
- Power (outputs)<sub>MAX</sub> =  $V_{DDO\_MAX} * I_{DDO\_MAX} = 3.465V * 59mA = 204mW$

**Total Power<sub>MAX</sub> = 492mW + 204mW = 696mW**

### 2. Junction Temperature.

Junction temperature,  $T_j$ , is the temperature at the junction of the bond wire and bond pad directly affects the reliability of the device. The maximum recommended junction temperature is 125°C. Limiting the internal transistor junction temperature,  $T_j$ , to 125°C ensures that the bond wire and bond pad temperature remains below 125°C.

The equation for  $T_j$  is as follows:  $T_j = \theta_{JA} * Pd\_total + T_A$

$T_j$  = Junction Temperature

$\theta_{JA}$  = Junction-to-Ambient Thermal Resistance

$Pd\_total$  = Total Device Power Dissipation (example calculation is in section 1 above)

$T_A$  = Ambient Temperature

In order to calculate junction temperature, the appropriate junction-to-ambient thermal resistance  $\theta_{JA}$  must be used. Assuming a moderate air flow of 200 linear feet per minute and a multi-layer board, the appropriate value is 39.7°C/W per Table 7 below.

Therefore,  $T_j$  for an ambient temperature of 70°C with all outputs switching is:

$$70^\circ\text{C} + 0.696\text{W} * 39.7^\circ\text{C/W} = 97.6^\circ\text{C}. \text{ This is well below the limit of } 125^\circ\text{C}.$$

This calculation is only an example.  $T_j$  will obviously vary depending on the number of loaded outputs, supply voltage, air flow and the type of board (multi-layer).

**Table 7. Thermal Resistance  $\theta_{JA}$  for 20 Lead SOIC, Forced Convection**

$\theta_{JA}$ vs. Air Flow			
Linear Feet per Minute	0	200	500
Single-Layer PCB, JEDEC Standard Test Boards	83.2°C/W	65.7°C/W	57.5°C/W
Multi-Layer PCB, JEDEC Standard Test Boards	46.2°C/W	39.7°C/W	36.8°C/W

NOTE: Most modern PCB designs use multi-layered boards. The data in the second row pertains to most designs.



## Reliability Information

**Table 8.  $\theta_{JA}$  vs. Air Flow Table for a 20 Lead SOIC**

$\theta_{JA}$ vs. Air Flow			
Linear Feet per Minute	0	200	500
Single-Layer PCB, JEDEC Standard Test Boards	83.2°C/W	65.7°C/W	57.5°C/W
Multi-Layer PCB, JEDEC Standard Test Boards	46.2°C/W	39.7°C/W	36.8°C/W

NOTE: Most modern PCB designs use multi-layered boards. The data in the second row pertains to most designs.

## Transistor Count

The transistor count for 8745B-21 is: 2772

## Package Outline and Package Dimensions

**Package Outline - M Suffix for 20 Lead SOIC**

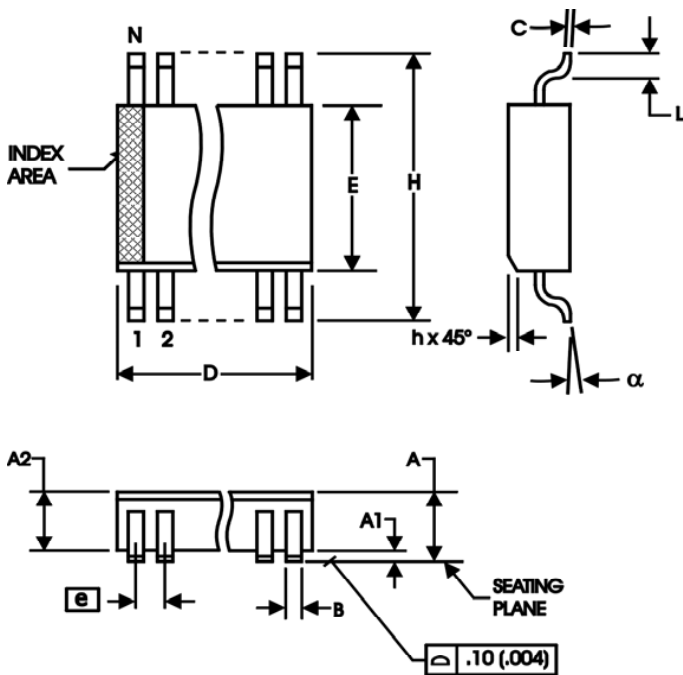

**Table 9. Package Dimensions for 20 Lead SOIC**

300 Millimeters All Dimensions in Millimeters		
Symbol	Minimum	Maximum
N	20	
A		2.65
A1	0.10	
A2	2.05	2.55
B	0.33	0.51
C	0.18	0.32
D	12.60	13.00
E	7.40	7.60
e	1.27 Basic	
H	10.00	10.65
h	0.25	0.75
L	0.40	1.27
$\alpha$	0°	7°

Reference Document: JEDEC Publication 95, MS-013, MS-119

## Ordering Information

Table 10. Ordering Information

Part/Order Number	Marking	Package	Shipping Packaging	Temperature
8745BM-21LF	ICS8745BM-21LF	"Lead-Free" 20 Lead SOIC	Tube	0°C to 70°C
8745BM-21LFT	ICS8745BM-21LF	"Lead-Free" 20 Lead SOIC	1000 Tape & Reel	0°C to 70°C

NOTE: Parts that are ordered with an "LF" suffix to the part number are the Pb-Free configuration and are RoHS compliant.

## Revision History Sheet

Rev	Table	Page	Description of Change	Date
B	T4D	5	LVDS DC Characteristics Table - modified VOS 0.90V min. to 1.05V min, 1.15V typical to 1.2V typical, and 1.4V max. to 1.35V max.	3/17/04
B	T9	1 14	Added Lead-Free bullet. Ordering Information Table - added Lead-Free part and note.	12/2/04
C	T6	7 12 15	AC Characteristics Table - changed $t_{PD}$ max limit from 3.7ns to 4.0ns. Added Recommendations for Unused Input & Output Pins. Added Power Considerations section. Updated format throughout the datasheet.	4/17/07
D	T4C T6 T10	1 6 7 10 11 17	Pin Assignment - corrected lineup of pin names. Differential DC Characteristics Table - updated NOTES. AC Characteristics Table - added thermal note. Power Supply Filtering Technique - updated paragraph. Updated <i>Differential Clock Input Interface</i> . Ordering Information Table - added "LF" marking. Deleted "ICS" prefix in Part/Order number column. Updated Header/Footer of datasheet.	1/25/10
D	T10	17	Ordering Information - Removed leaded Devices - PDN CQ-13-02 Updated Datasheet format	2/17/15



**Corporate Headquarters**  
6024 Silver Creek Valley Road  
San Jose, CA 95138 USA

**Sales**  
1-800-345-7015 or 408-284-8200  
Fax: 408-284-2775  
www.IDT.com

**Tech Support**  
email: [clocks@idt.com](mailto:clocks@idt.com)

DISCLAIMER Integrated Device Technology, Inc. (IDT) and its subsidiaries reserve the right to modify the products and/or specifications described herein at any time and at IDT's sole discretion. All information in this document, including descriptions of product features and performance, is subject to change without notice. Performance specifications and the operating parameters of the described products are determined in the independent state and are not guaranteed to perform the same way when installed in customer products. The information contained herein is provided without representation or warranty of any kind, whether express or implied, including, but not limited to, the suitability of IDT's products for any particular purpose, an implied warranty of merchantability, or non-infringement of the intellectual property rights of others. This document is presented only as a guide and does not convey any license under intellectual property rights of IDT or any third parties.

IDT's products are not intended for use in applications involving extreme environmental conditions or in life support systems or similar devices where the failure or malfunction of an IDT product can be reasonably expected to significantly affect the health or safety of users. Anyone using an IDT product in such a manner does so at their own risk, absent an express, written agreement by IDT.

While the information presented herein has been checked for both accuracy and reliability, Integrated Device Technology (IDT) assumes no responsibility for either its use or for the infringement of any patents or other rights of third parties, which would result from its use. No other circuits, patents, or licenses are implied. This product is intended for use in normal commercial applications. Any other applications, such as those requiring extended temperature ranges, high reliability or other extraordinary environmental requirements are not recommended without additional processing by IDT. IDT reserves the right to change any circuitry or specifications without notice. IDT does not authorize or warrant any IDT product for use in life support devices or critical medical instruments.

Integrated Device Technology, IDT and the IDT logo are registered trademarks of IDT. Product specification subject to change without notice. Other trademarks and service marks used herein, including protected names, logos and designs, are the property of IDT or their respective third party owners.

Copyright ©2015 Integrated Device Technology, Inc.. All rights reserved.