

阅读申明

- 1.本站收集的数据手册和产品资料都来自互联网，版权归原作者所有。如读者和版权方有任何异议请及时告之，我们将妥善解决。
- 2.本站提供的中文数据手册是英文数据手册的中文翻译，其目的是协助用户阅读，该译文无法自动跟随原稿更新，同时也可能存在翻译上的不当。建议读者以英文原稿为参考以便获得更精准的信息。
- 3.本站提供的产品资料，来自厂商的技术支持或者使用者的心得体会等，其内容可能存在描述上的差异，建议读者做出适当判断。
- 4.如需与我们联系，请发邮件到marketing@iczoom.com，主题请标有“数据手册”字样。

Read Statement

1. The datasheets and other product information on the site are all from network reference or other public materials, and the copyright belongs to the original author and original published source. If readers and copyright owners have any objections, please contact us and we will deal with it in a timely manner.
2. The Chinese datasheets provided on the website is a Chinese translation of the English datasheets. Its purpose is for reader's learning exchange only and do not involve commercial purposes. The translation cannot be automatically updated with the original manuscript, and there may also be improper translations. Readers are advised to use the English manuscript as a reference for more accurate information.
3. All product information provided on the website refer to solutions from manufacturers' technical support or users the contents may have differences in description, and readers are advised to take the original article as the standard.
4. If you have any questions, please contact us at marketing@iczoom.com and mark the subject with "Datasheets" .

CBC34123 EnerChip™ RTC

SPI Real-Time Clock/Calendar with Integrated Backup Power

Features

- Integrated rechargeable solid state battery with power-fail detect and automatic switchover, **providing greater than 30 hours of RTC backup**
- Smallest commercially available RTC with integrated backup power in compact 5mm x 5mm 1.4mm QFN package
- Temperature compensated charge control
- Integrated EnerChip™ recharged at VDD > 2.5V
- SMT assembly - lead-free reflow solder tolerant
- Real time clock provides year, month, day, week-day, hours, minutes, and seconds based on a 32.768 kHz quartz crystal
- Resolution: seconds to years
- Watchdog functionality
- Freely programmable timer and alarm with interrupt capability
- 3-line SPI-bus with separate, but combinable data input and output
- Integrated oscillator load capacitors for $C_L = 7$ pF
- Internal Power-On Reset (POR)
- Open-drain interrupt and clock output pins
- Programmable offset register for frequency adjustment
- Eco-friendly, RoHS compliant - tested

Applications

- **Wireless sensors and RFID tags** and other powered, low duty cycle applications.
- **Power bridging** to provide uninterruptible RTC function during exchange of main batteries.
- **Consumer appliances** that have real-time clocks; provides switchover power from main supply to backup battery.
- **Business and industrial systems** such as: network routers, point-of-sale terminals, single-board computers, test equipment, multi-function printers, industrial controllers, and utility meters.
 - Time keeping application
 - Battery powered devices
 - Metering
 - High duration timers
 - Daily alarms
 - Low standby power applications

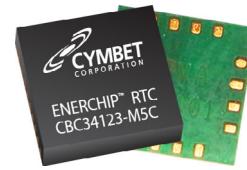

5mm x 5mm x 1.4mm 16-QFN Package

General Description

The EnerChip RTC CBC34123-M5C combines a Real-Time Clock (RTC) and calendar optimized for low power applications with an integrated rechargeable solid state backup battery and all power management functions. The EnerChip RTC ensures a seamless transition from main power to backup power in the event of power loss. The integrated power management circuit ensures thousands of charge-discharge cycles from the integrated EnerChip and manages battery charging, discharge cutoff, power switchover, and temperature compensation to maximize the service life of the device. The CBC34123 provides greater than 30 hours of backup time in the event main power is interrupted. Typical blackout times are less than 4 hours. Longer backup time can be achieved by adding an external EnerChip to the VCHG pin. The EnerChip has extremely low self-discharge, recharges quickly, is non-flammable, and RoHS-compliant. The EnerChip is charged automatically anytime VDD is above 2.5V.

Data is transferred serially via a Serial Peripheral Interface (SPI-bus) with a maximum data rate of 6.25 Mbit/s. Alarm and timer functions provide the option to generate a wake-up signal on an interrupt pin. An offset register allows fine tuning of the clock.

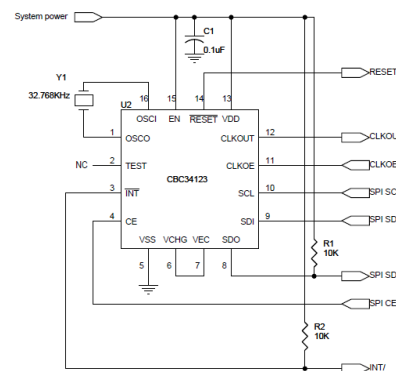

Figure 1: CBC34123 Pin-out Diagram

CBC34123 EnerChip™ RTC

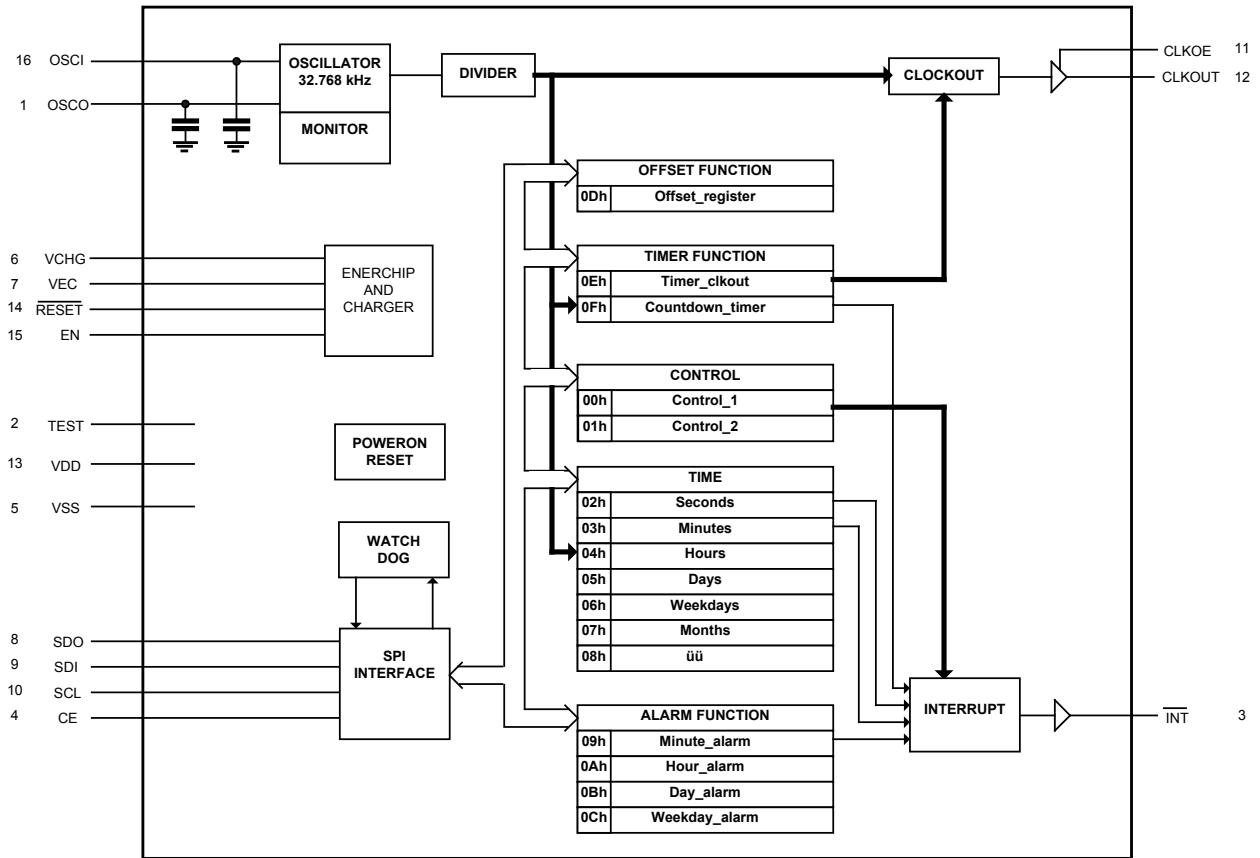

Figure 2: CBC34123 Block Diagram with Registers

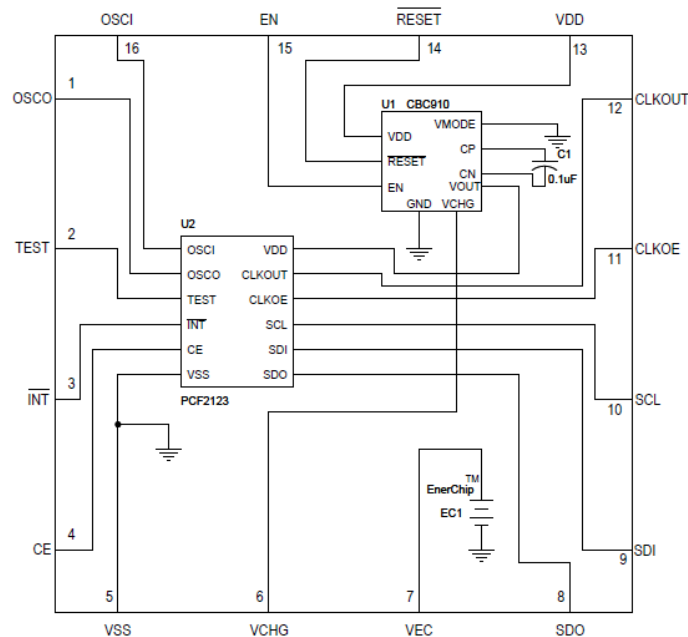

Figure 3: Internal Schematic of CBC34123 EnerChip RTC

CBC34123 EnerChip™ RTC

CBC34123 Input/Output Descriptions

Pin Number	Label	Description
1	OSCO	Oscillator output; high-impedance node; minimize wire length between quartz and package
2	TEST	Test pin; not user accessible; connect to VSS or leave floating (internally pulled down)
3	INT/	Interrupt output (open-drain; active LOW)
4	CE	Chip enable input (active HIGH) with internal pull down
5	VSS	Ground
6	VCHG	4.1V (typical) charging source - connect to VEC and/or optional EnerChip(s) for extended backup time
7	VEC	Positive terminal of integrated thin film battery - connect only to VCHG via PCB trace
8	SDO	Serial data output, push-pull; high-impedance when not driving; can be connected to SDI for single wire data line
9	SDI	Serial data input; may float when CE is inactive
10	SCL	Serial clock input; may float when CE is inactive
11	CLKOE	CLKOUT enable or disable pin; enable is active HIGH; connect to VSS for low power operation
12	CLKOUT	Clock output (open-drain)
13	VDD	Supply voltage; positive or negative steps in VDD can affect oscillator performance; recommend 100nF decoupling close to the device
14	RESET/	Output signal indicating RTC is operating in backup power mode
15	EN	Charge pump enable; activates VCHG 4.1V (typ.) charging source
16	OSCI	Oscillator input; high-impedance node; minimize wire length between quartz and package

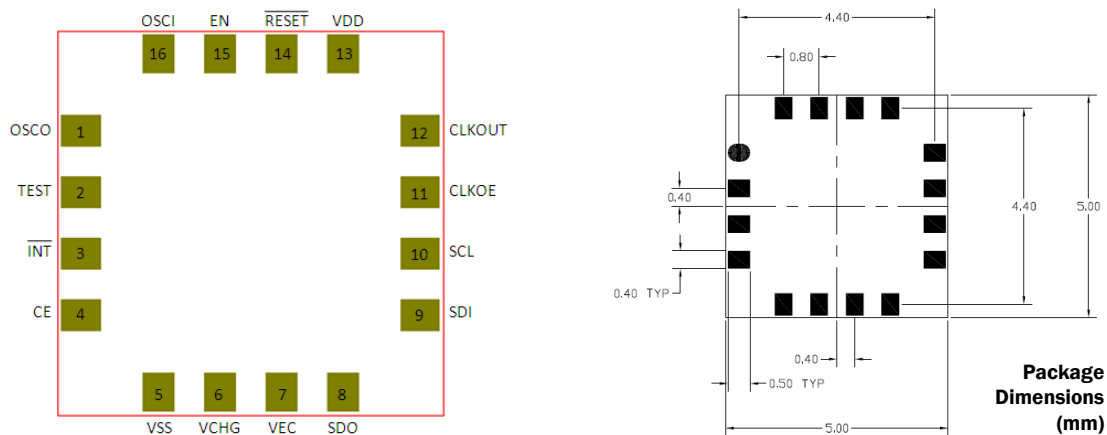

Figure 4: CBC34123 Package (left: top view, looking through package; right: pad dimensions)

EnerChip Properties

Energy capacity (typical):	5 μ Ah
Recharge time to 80%:	10 minutes
Charge/discharge cycles:	>5000 to 10% depth-of-discharge
Operating temperature:	-30 °C to +70 °C
Storage temperature:	-40 °C to +125 °C
Minimum VDD to charge EnerChip:	2.5V

Absolute Maximum Ratings

PARAMETER / PIN	CONDITION	MIN	TYPICAL	MAX	UNITS
VDD with respect to GND	25 °C	GND - 0.3	-	6.0	V
ENABLE Input Voltage	25 °C	GND - 0.3	-	VDD+0.3	V
VEC ⁽¹⁾	25 °C	3.0	-	4.15	V
VCHG ⁽¹⁾	25 °C	3.0	-	4.15	V
$\overline{\text{RESET}}$ Output Voltage	25 °C	GND - 0.3	-	2.7	V
INT/, CE, TEST, OSC1, OSC0, SDO, SDI, SCL, CLKOE, CLKOUT	See NXP PCF2123 Data Sheet				

⁽¹⁾ No external connections to these pins are allowed, except parallel EnerChips for extended backup time.

Integrated EnerChip Thin Film Battery Operating Characteristics

PARAMETER	CONDITION	MIN	TYPICAL	MAX	UNITS	
Self-Discharge (5 yr. average)	Non-recoverable	-	2.5	-	% per year	
	Recoverable	-	1.5 ⁽¹⁾	-	% per year	
Operating Temperature	-	-30	25	+70	°C	
Storage Temperature	-	-40	-	+125 ⁽²⁾	°C	
Recharge Cycles (to 80% of rated capacity)	25 °C	10% depth-of-discharge	5000	-	-	cycles
		50% depth-of discharge	1000	-	-	cycles
	40 °C	10% depth-of-discharge	2500	-	-	cycles
		50% depth-of-discharge	500	-	-	cycles
Recharge Time (to 80% of rated capacity; 4.1V charge; 25 °C) ⁽³⁾	Charge cycle 2	-	11	22	minutes	
	Charge cycle 1000	-	45	70		
Capacity (see Figure 5)	40nA discharge; 25 °C	5	-	-	µAh	

⁽¹⁾ First month recoverable self-discharge is 5% average.

⁽²⁾ Storage temperature is for uncharged EnerChip CC device.

⁽³⁾ EnerChip charging time increases approximately 2x per 10°C decrease in temperature.

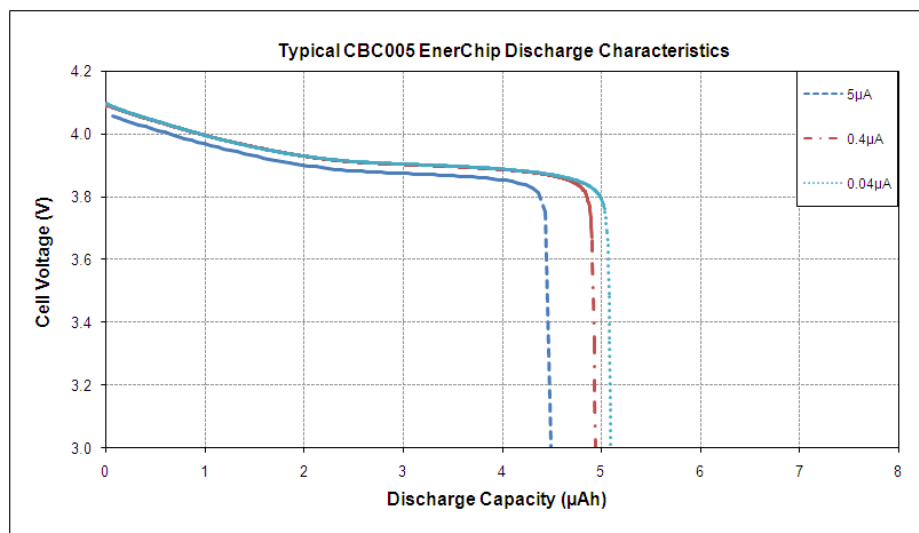

Figure 5: Typical Discharge Characteristics of the CBC005 EnerChip Within the CBC34123

Note: All specifications contained within this document are subject to change without notice.

POWER SUPPLY CURRENT CHARACTERISTICS OF INTEGRATED CBC910 POWER MANAGEMENT CIRCUIT ONLY
Ta = -20°C to +70°C

CHARACTERISTIC	SYMBOL	CONDITION	MIN	MAX	UNITS	
Quiescent Current (CBC910 power management circuit only; V _{DD} > V _{RESET} ; RTC current not included)	I _Q	ENABLE=GND	V _{DD} =3.3V	-	3.5	μA
			V _{DD} =5.5V	-	6.0	μA
		ENABLE=V _{DD}	V _{DD} =3.3V	-	35	μA
			V _{DD} =5.5V	-	38	μA
EnerChip Cutoff Current (I _{QBATON} adds to RTC current when in backup mode)	I _{QBATOFF}	V _{BAT} < V _{BATCO} , V _{OUT} =0	-	0.5	nA	
	I _{QBATON}	V _{BAT} > V _{BATCO} , I _{OUT} =0	-	42	nA	

INTERFACE LOGIC SIGNAL CHARACTERISTICS
V_{DD} = 2.5V to 5.5V, Ta = -20°C to +70°C

CHARACTERISTIC	SYMBOL	CONDITION	MIN	MAX	UNITS
High Level Input Voltage	V _{IH}	-	V _{DD} - 0.5	-	Volts
Low Level Input Voltage	V _{IL}	-	-	0.5	Volts
High Level Output Voltage	V _{OH}	V _{DD} > V _{TH} (see Figures 4 and 5) I _L =10μA	V _{DD} - 0.04V ⁽¹⁾	-	Volts
Low Level Output Voltage	V _{OL}	I _L = -100μA	-	0.3	Volts
Logic Input Leakage Current	I _{IN}	0 < V _{IN} < V _{DD}	-1.0	+1.0	nA

⁽¹⁾ \overline{RESET} tracks V_{DD}; $\overline{RESET} = V_{DD} - (I_{OUT} \times R_{OUT})$.

 \overline{RESET} SIGNAL AC/DC CHARACTERISTICS
V_{DD} = 2.5V to 5.5V, Ta = -20°C to +70°C

CHARACTERISTIC	SYMBOL	CONDITION	MIN	MAX	UNITS
V _{DD} Rising to \overline{RESET} Rising	t _{RESETH}	V _{DD} rising from 2.8V TO 3.1V in <10μs	60	200	ms
V _{DD} Falling to \overline{RESET} Falling	t _{RESETL}	V _{DD} falling from 3.1V to 2.8V in <100ns	0.5	2	μs
TRIP Voltage V _{DD} Rising	V _{RESET}	V _{MODE} =GND	2.85	3.15	V
\overline{RESET} Hysteresis Voltage (V _{DD} to \overline{RESET})	V _{HYST}	V _{MODE} =GND	45	75	mV

CHARGE PUMP CHARACTERISTICS (PERTAINS TO INTEGRATED CBC910 POWER MANAGEMENT CIRCUIT)**V_{DD} = 2.5V to 5.5V, T_a = -20°C to +70°C**

CHARACTERISTIC	SYMBOL	CONDITION	MIN	MAX	UNITS
ENABLE=V _{DD} to Charge Pump Active	t _{CPON}	ENABLE to 3rd charge pump pulse, V _{DD} =3.3V	60	80	μs
ENABLE Falling to Charge Pump Inactive	t _{CPOFF}	-	0	1	μs
Charge Pump Frequency	f _{CP}		-	120	KHz ⁽¹⁾
Charge Pump Resistance	R _{CP}	Delta V _{BAT} , for I _{BAT} charging current of 1μA to 100μA C _{FLY} =0.1μF, C _{BAT} =1.0μF	150	300	Ω
V _{CHG} Output Voltage	V _{CP}	C _{FLY} =0.1μF, C _{BAT} =1.0μF, I _{OUT} =1μA, Temp=+25°C	4.065	4.150	V
V _{CHG} Temp. Coefficient	T _{CCP}	I _{OUT} =1μA, Temp=+25°C	-2.0	-2.4	mV/°C
Charge Pump Current Drive	I _{CP}	I _{BAT} =1mA C _{FLY} =0.1μF, C _{BAT} =1.0μF	1.0	-	mA
Charge Pump on Voltage	V _{ENABLE}	ENABLE=V _{DD}	2.5	-	V

⁽¹⁾ f_{CP} = 1/t_{CPPER}**ADDITIONAL CHARACTERISTICS****T_a = -20°C to +70°C**

CHARACTERISTIC	SYMBOL	CONDITION	LIMITS		UNITS
			MIN	MAX	
V _{BAT} Cutoff Threshold	V _{BATCO}	I _{OUT} =1μA	2.75	3.25	V
Cutoff Temp. Coefficient	T _{CCO}	-	+1	+2	mV/°C
V _{BAT} Cutoff Delay Time	t _{COFF}	V _{BAT} from 40mV above to 20mV below V _{BATCO} I _{OUT} =1μA	18	-	ms

Note: All specifications contained within this document are subject to change without notice

Important Reference Documents

For complete specifications of the integrated PCF2123 Real-Time Clock, see here:

http://www.cymbet.com/pdfs/NXP_RTC_PCF2123.pdf

For complete specifications of the Cymbet 5μAh EnerChip and integrated power management circuit, see here:

<http://www.cymbet.com/pdfs/DS-72-41.pdf>.

For guidelines regarding crystal selection and other important information pertaining to the PCF2123, see UM10301 - User Manual for NXP Real Time Clocks, located here:

http://www.nxp.com/documents/user_manual/UM10301.pdf

Functional Description of Integrated CBC34123 Real-Time Clock

The CBC34123 contains 16 8-bit registers with an auto-incrementing address counter, an on-chip 32.768 kHz oscillator with two integrated load capacitors, a frequency divider which provides the source clock for the Real Time Clock (RTC), a programmable clock output, and a 6.25 Mbit/s SPI-bus. An offset register allows fine tuning of the clock.

All 16 registers are designed as addressable 8-bit parallel registers although not all bits are implemented.

- The first two registers (memory address 00h and 01h) are used as control registers.
- The memory addresses 02h through 08h are used as counters for the clock function (seconds up to years). The registers Seconds, Minutes, Hours, Days, Weekdays, Months, and Years are all coded in Binary Coded Decimal (BCD) format. When one of the RTC registers is written or read the contents of all counters are frozen. Therefore, faulty writing or reading of the clock and calendar during a carry condition is prevented.
- Addresses 09h through 0Ch define the alarm condition.
- Address 0Dh defines the offset calibration.
- Address 0Eh defines the clock out and timer mode.
- Address registers 0Eh and 0Fh are used for the countdown timer function. The countdown timer has four selectable source clocks allowing for countdown periods in the range from 244 ms up to four hours. There are also two pre-defined timers which can be used to generate an interrupt once per second or once per minute. These are defined in register Control_2 (01h).

Low Power Operation

Minimum power operation will be achieved by reducing the number and frequency of switching signals inside the IC, i.e., low frequency timer clocks and a low frequency CLKOUT will result in lower operating power. A second prime consideration is the series resistance R_s of the quartz used.

Power Consumption with Respect to Quartz Series Resistance

The series resistance acts as a loss element. Low R_s will reduce current consumption further.

CBC34123 Register Overview

16 registers are available. The time registers are encoded in the Binary Coded Decimal (BCD) format to simplify application use. Other registers are either bit-wise or standard binary.

Bit positions labeled as '-' are not implemented and will return a '0' when read. The bit position labeled as '--' is not implemented and will return a '0' or '1' when read. Bit positions labeled with N should always be written with logic '0' ⁽¹⁾.

Address	Register name	Bit							
		7	6	5	4	3	2	1	0
Control and status registers									
00h	Control_1	EXT_TEST	N	STOP	SR	N	12_24	CIE	N
01h	Control_2	MI	SI	MSF	TI_TP	AF	TF	AIE	TIE
Time and date registers									
02h	Seconds	OS	SECONDS (0 to 59)						
03h	Minutes	--	MINUTES (0 to 59)						
04h	Hours	-	-	AMPM	HOURS (1 to 12) in 12 h mode HOURS (0 to 23) in 24 h mode				
05h	Days	-	-	DAYS (1 to 31)					
06h	Weekdays	-	-	-	-	-	WEEKDAYS (0 to 6)		
07h	Months	-	-	-	MONTHS (1 to 12)				
08h	Years	YEARS (0 to 99)							
Alarm registers									
09h	Minute_alarm	AE_M	MINUTE_ALARM (0 to 59)						
0Ah	Hour_alarm	AE_H	-	AMPM	HOUR_ALARM (1 to 12) in 12 h mode HOUR_ALARM (0 to 23) in 24 h mode				
0Bh	Day_alarm	AE_D	-	DAY_ALARM (1 to 31)					
0Ch	Weekday_alarm	AE_W	-	-	-	-	WEEKDAY_ALARM (0 to 6)		
Offset register									
0Dh	Offset_register	MODE	OFFSET[6:0]						
Timer registers									
0Eh	Timer_clkout	-	COF[2:0]			TE	-	CTD[1:0]	
0Fh	Countdown_timer	COUNTDOWN_TIMER[7:0]							

[1] Except in the case of software reset, see [Section 8.3.1.1](#).

CBC34123 EnerChip™ RTC

Typical CBC34123 EnerChip RTC Connection to Microcontroller

Figure 5 illustrates how the CBC34123 is typically connected to a microcontroller (MCU) in a system. For simplicity, only the MCU lines routed to/from the CBC34123 are shown. The I/O line from the MCU to the EN pin of the CBC34123 is optional for reducing power consumption of the CBC34123. The EN pin can be forced low by the MCU when the integrated EnerChip does not need to be charged. If EN is not connected to the MCU or otherwise controlled externally, it must be tied to VDD to ensure the EnerChip is charged when VDD is valid.

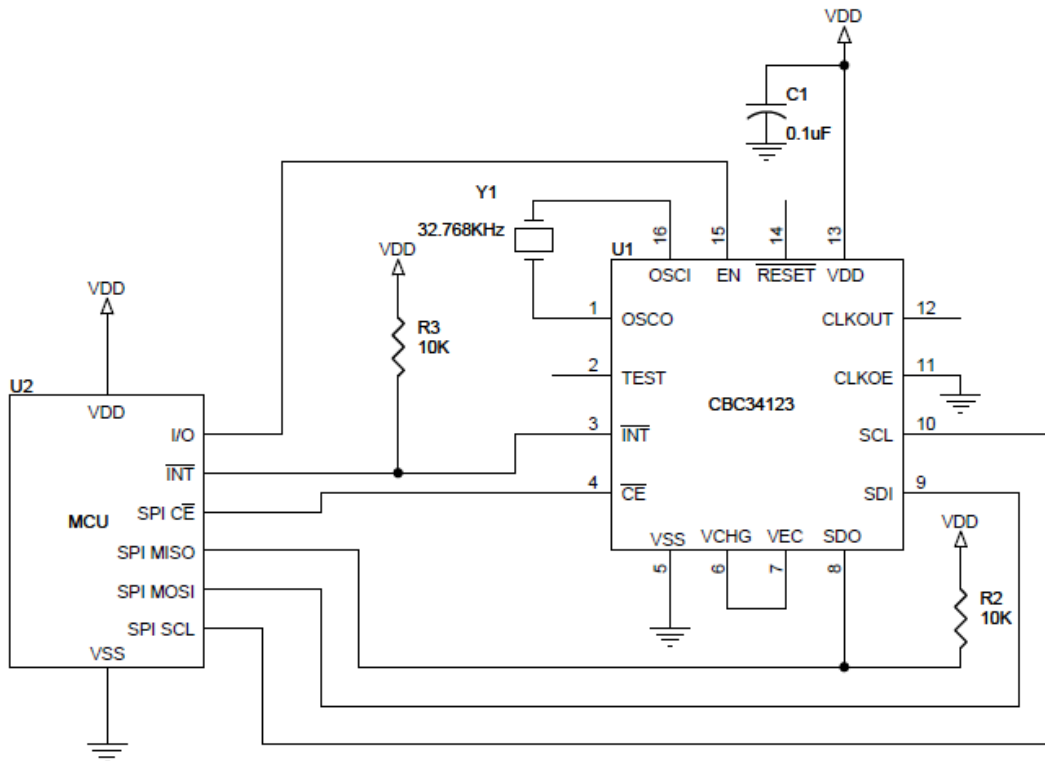

Figure 5: Typical Application Schematic Showing MCU Connections to CBC34123

GUIDELINES FOR HANDLING ENERCHIP RTC DEVICES

The EnerChip™ RTC with an integrated thin film, solid state battery features all solid state construction, are packaged in standard integrated circuit packages, and can be reflow soldered for high volume PCB assembly.

The CBC34123 EnerChip RTC is considered an MSL-3 rated device for storage and handling purposes.

Device Handling & Storage

- EnerChip RTCs are packaged and shipped in tubes or reels in moisture barrier bags, and are sensitive to moisture absorption. They must be kept in the sealed bag until ready for board mounting and reflow soldering.
- If the EnerChip RTCs are removed from the sealed bag more than 168 hours prior to board mounting, they must be baked at 125°C for a minimum of 24 hours prior to board mounting and reflow soldering.
- Store the EnerChip RTCs in an environment where the temperature and humidity do not undergo large fluctuations. Store at 10°C to 30°C and at less than 60% relative humidity.

Electrostatic Discharge (ESD)

- The EnerChip RTCs are sensitive to ESD damage prior to receiving a battery charge cycle. Therefore, adherence to ESD prevention guidelines is required.
- Remove RTC devices from protective shipping and storage containers at approved ESD workstations only.
- All equipment used to process the devices must be configured to minimize the generation of static charges. This includes soldering and de-soldering equipment and tools, pick-and-place equipment, test equipment, and all other tools and equipment used to handle or process the devices.
- Failure to observe these precautions can lead to premature failure and shall void product warranty.

Other Use Guidelines

- Do not connect the EnerChip RTC to other types of batteries.
- To increase battery life, avoid placing the EnerChip RTC near devices that would generate heat exceeding the 70°C operating limit.

DO NOT HAND SOLDER ENERCHIP RTC DEVICES

When soldering an individual uncharged EnerChip RTC, a QFN capable soldering station with temperature control should be used. It is very important to be able to control the solder temperature and time when soldering an EnerChip RTC.

ENERCHIP ASSEMBLY REPAIR TECHNIQUES

For the EnerChip RTC QFN package, use a hot air rework station to remove a defective or misplaced EnerChip package. If there are other EnerChips in the vicinity of the EnerChip being replaced, use proper heat shielding to protect the adjacent EnerChip package from the heat source and turn off any heat source that would otherwise be used to heat the bottom of the board during removal of the EnerChip. This will prevent the adjacent EnerChip(s) from being damaged during the rework procedure.

SMT PROCESS

The EnerChip RTCs are packaged in standard surface mount packages. Refer to the solder paste material data sheets for attachment of the package to a PCB using solder reflow processes. Ensure that the solder reflow oven is programmed to the correct temperature profile prior to assembling the EnerChip RTC on the PCB.

REFLOW SOLDERING

- The maximum number of times an uncharged EnerChip RTC may be reflow soldered is three times.
- **The surface temperature of the EnerChip RTC package must not exceed 240 °C.**
- The recommended solder reflow profile is shown in Figure 6 below; refer to the table for time and temperature requirements. Whenever possible, use lower temperature solder reflow profiles.

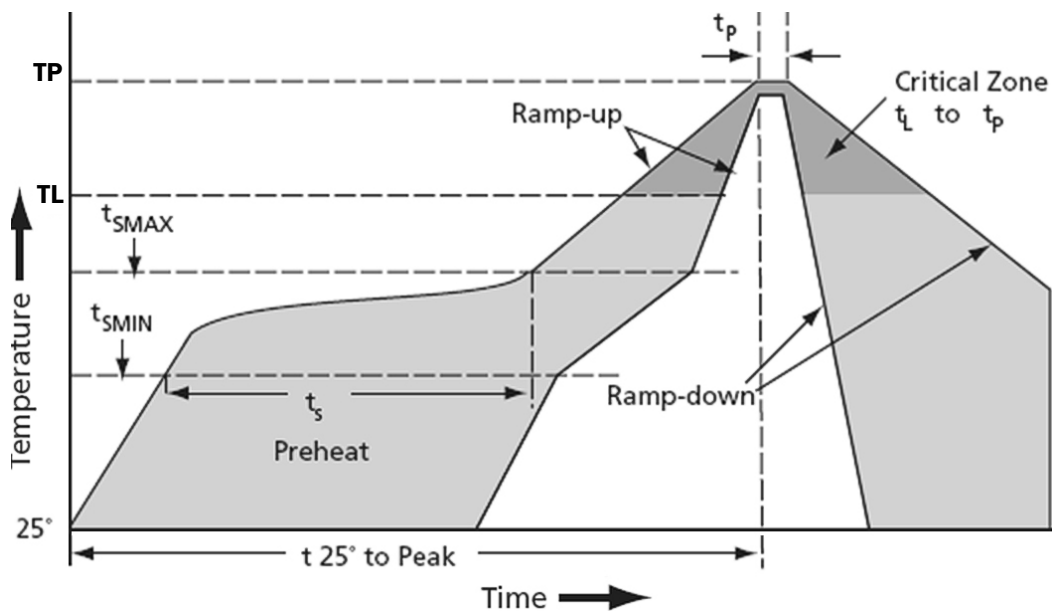

Parameter	Sn/Pb	Pb-free
Soak temperature, min, TSMIN	100 °C	150 °C
Soak temperature, max, TSMAX	150 °C	200 °C
Soak time, max, tS	2 min	2 min
Max ramp-up rate (TL to TP)	3 °C/sec	3 °C/sec
Liquidous temperature, TL	183 °C	217 °C
Time tL maintained above TL	60-150 sec	60-150 sec
Max peak temperature, TP	220 °C	240 °C
Max time tP at peak temperature TP	20 sec	30 sec
Max ramp-down rate (TP to TL)	6 °C/sec	6 °C/sec
Time 25 °C to peak temperature	6 min max	8 min max

Figure 6: EnerChip RTC Solder Reflow Profile and Specification Table

GUIDELINES FOR IN-CIRCUIT TESTING OF THE INTERNAL ENERCHIP BATTERY

It is very important to verify EnerChip device connectivity after reflow solder process. It is important to read and understand the proper test flow for the EnerChip devices. Following the proper test method will ensure reworkability of boards.

Precautions and Important Processes

After assembly on a printed circuit board, the CBC34123 integrated solid state battery is in an uncharged state. It is important that the CBC34123 battery remain untested and uncharged until the last step of an in-circuit system test so that if other components fail test and need to be replaced, the CBC34123 will still be in a reflow-solderable state. The crystal and RTC in the CBC34123 can be tested independently from the battery at the same time the other system elements are being tested.

There are two considerations when doing post-assembly testing of the user's circuit board:

1. When performing circuit testing, short the internal EnerChip battery to GND by forcing the VCHG/VEC pins to ground potential during testing of the EnerChip RTC and other circuit functions. This will prevent the integrated EnerChip from accumulating charge while the CBC34123 VDD and EN pins are active.
2. When the overall circuit testing is complete, it is permissible to verify connection to the EnerChip battery and 4.1V output of the charge pump at the VCHG pin by forcing the CBC34123 VDD and EN pins high for **NO MORE THAN 3 SECONDS**. Activating the charge pump for longer than 3 seconds will put sufficient charge into the EnerChip that board level rework is no longer permitted without destroying the EnerChip.

Factory In-Circuit EnerChip Post Assembly Test Steps**CBC34123 In-Circuit Test Procedure**

1. In order to keep the CBC34123 battery from charging during testing, apply GND using an in-circuit test bed pin or other shorting method to the VCHG and VEC pins (6 and 7, respectively) that are normally tied together on the PCB. Alternatively, the EN pin on the CBC34123 can be forced to a logic low before performing board level testing as this will also prevent charge from accumulating in the battery. *WARNING: If the enable pin is asserted for more than 3 seconds with $VDD \geq 2.5$ volts, the CBC34123 may not be reflowed again.*
2. Enable power domains under test, with VCHG/VEC net shorted to GND or EN forced to a logic low level.
3. Run all vectors to ensure proper functionality of all semiconductor devices.
4. After all other circuits are functional and boards have been reworked if needed.
5. Apply voltage to VIN that is in the range of 2.5V to 5.5V. (Note: VIN = VDD.)
6. Verify that the VCHG/VEC net is 4.1 volts +/- 0.025 volts.
7. Allow the battery to charge a very small amount by leaving the device in the above-noted configuration for one second.
8. The chart in Figure 7 should be referenced to determine the voltage on the VCHG/VEC pin to be expected after driving the ENABLE pin high for one second. The decay curves in the chart represent specific load impedances as might be encountered with Automated Test Equipment (ATE). Additionally, the decay curves represent the span of EnerChip cell impedances as specified in the respective data sheets. Note: If not using ATE with the ability to add a load impedance, it will be necessary to add resistance in parallel with the voltage measurement device so the readings will match the graph of Figure 7. Any measurement equipment and associated impedance circuits must only be temporally tied to the VCHG/VEC node for the time needed to make the measurement (seconds) and no longer as the measurement impedance will cause the battery to become discharged below 2.5V at which time the cell will become permanently damaged.
9. The graph in Figure 7 depicts the time-dependent and temperature-dependent voltage of the EnerChip RTC after applying a 4.1VDC charging voltage for approximately one second, followed by a brief discharge at a specific load resistance. Using this graph as a guide, the test engineer can develop a simple test that is feasible with the available test equipment and fixtures and meets the production throughput needs.

1. The test engineer has the freedom to choose a point on the discharge curve that falls within the parameters of test throughput and equipment measurement capability. In order for the EnerChip to be considered as meeting the gross functional test specification, the voltage on the VCHG/VEC pin must be above the value indicated by whichever line is chosen as the reference line.
2. Data at two temperatures is shown in order to encompass the range of anticipated factory test floors. Note the influence of temperature on the EnerChip test discharge voltage when setting the test specification pass/fail limits.

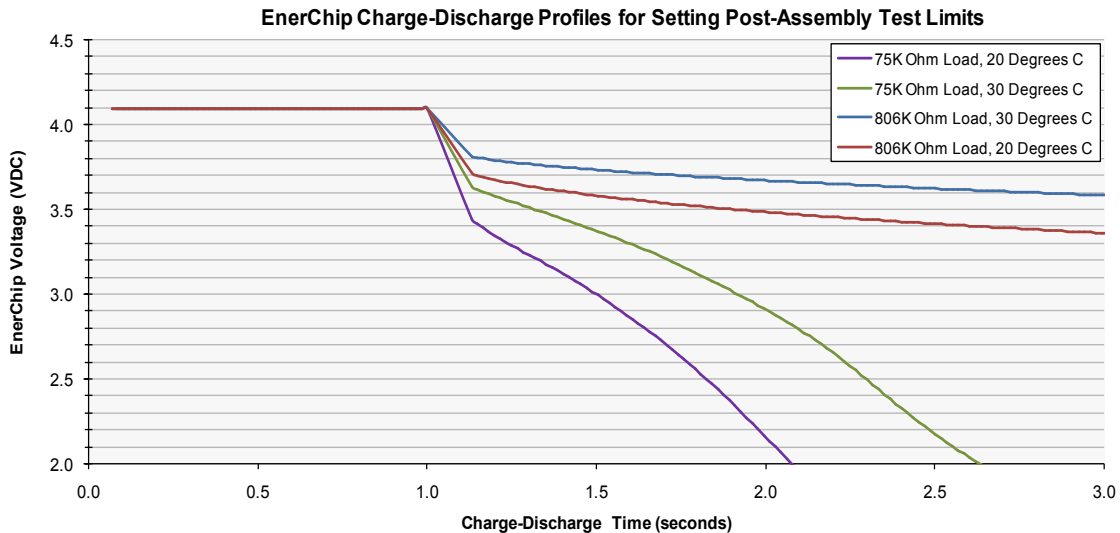

Figure 7: Voltage Determination on the VCHG/VEC Pin

CBC34123 Internal Battery Backup Verification: Optional Board/System Level Test. ⁽¹⁾

Warning: Board level reflow/rework is not permitted if the following procedure is used.

The following test is normally used in the prototype testing phase as this test may take 10-15 minutes to perform which is typically unsuitable for high speed in-circuit testing.

1. Power up board or system.
2. Ensure that CBC34123 EN pin 15 is asserted and VDD is > 2.5 volts.
3. Allow battery to charge for several minutes.
4. Program device to be battery-backed.
5. Remove power for at least several seconds to one minute.
6. Power up board or system.
7. Read device formerly under battery-backed operation.
8. Verify device contents.

Notes:

⁽¹⁾ This test does not verify the actual capacity of the integrated battery. In order to verify actual capacity, the device must be charged for at least one hour and then provide RTC power holdover until battery cut-off occurs.

CBC34123 EnerChip™ RTC

CBC34123 Packaging

EnerChip CBC34123 devices are packaging in tubes or reels. The following specifications are for the 1000 and 5000 part reel packaging configurations.

CBC34123-Q5C-TR1 is a 7 inch reel with 1000 parts. Cymbet uses the Advantek LOKREEL Mini RJ7xx packaging reel that has an outside diameter of 7 inches (180mm) and 1/2 inch (13mm) diameter arbor hole. Reel hubs measure 2.36 inches (60mm). The 7 inch reel is compliant with EIAJ standards for dimension and surface resistivity.

CBC34123-Q5C-TR5 is a 13 inch reel with 5000 parts. Cymbet uses the Advantek 13" LOKREEL packaging reel that has an outside diameter of 13 inches (330mm) and 1/2 inch (13mm) diameter arbor hole. Reel hubs measure 4 inches (102mm). The 13 inch reel is compliant with EIAJ standards for dimension and surface resistivity.

Cymbet Part	Package Type, # of Devices	Reel Size Outside Diameter - A	Tape Width W, W1 Cavity Pitch P1	Meters per Reel	Pockets/ Reel	Width A0	Length B0	Depth K0
CBC34123-M5C-TR1	QFN, 1000	180mm	16mm, 8 mm	108	7000	5.45	5.45	1.8
CBC34123-M5C-TR5	QFN, 5000	330mm	16mm, 8mm	540	13000	5.45	5.45	1.8

TAPE AND REEL INFORMATION

REEL DIMENSIONS

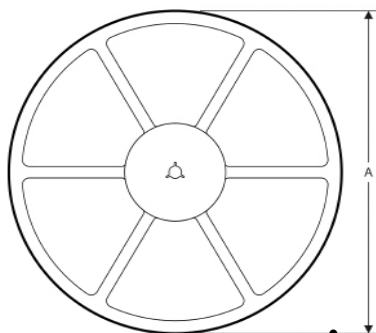

TAPE AND REEL INFORMATION

TAPE DIMENSIONS

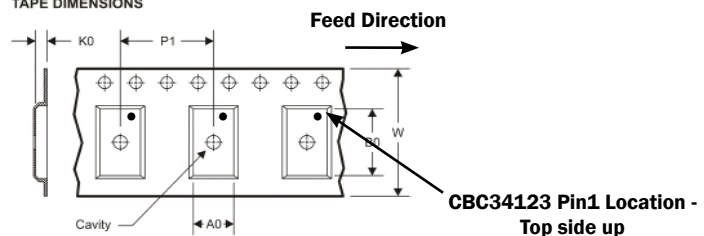

A0	Dimension designed to accommodate the component width
B0	Dimension designed to accommodate the component length
K0	Dimension designed to accommodate the component thickness
W	Overall width of the carrier tape
P1	Pitch between successive cavity centers

Ordering Information

EnerChip CC Part Number	Description	Notes
CBC34123-M5C	EnerChip RTC in 5mm x 5mm x 1.4mm 16-QFN Land Grid Array	Shipped in Tube
CBC34123-M5C-TR1 CBC34123-M5C-TR5	EnerChip RTC in 5mm x 5mm x 1.4mm 16-QFN Land Grid Array	Tape-and-Reel - 1000 pcs (TR1) or 5000 pcs (TR5) per reel
CBC-EVAL-12	EnerChip RTC Evaluation Kit	USB based Eval Kit with CBC34123 tab board

U.S. Patent No. 8,144,508. Additional U.S. and Foreign Patents Pending

Disclaimer of Warranties; As Is

The information provided in this data sheet is provided "As Is" and Cymbet Corporation disclaims all representations or warranties of any kind, express or implied, relating to this data sheet and the Cymbet EnerChip product described herein, including without limitation, the implied warranties of merchantability, fitness for a particular purpose, non-infringement, title, or any warranties arising out of course of dealing, course of performance, or usage of trade. Cymbet EnerChip products are not authorized for use in life critical applications. Users shall confirm suitability of the Cymbet EnerChip product in any products or applications in which the Cymbet EnerChip product is adopted for use and are solely responsible for all legal, regulatory, and safety-related requirements concerning their products and applications and any use of the Cymbet EnerChip product described herein in any such product or applications.

Cymbet, the Cymbet Logo, and EnerChip are Cymbet Corporation Trademarks