

阅读申明

- 1.本站收集的数据手册和产品资料都来自互联网，版权归原作者所有。如读者和版权方有任何异议请及时告之，我们将妥善解决。
- 2.本站提供的中文数据手册是英文数据手册的中文翻译，其目的是协助用户阅读，该译文无法自动跟随原稿更新，同时也可能存在翻译上的不当。建议读者以英文原稿为参考以便获得更精准的信息。
- 3.本站提供的产品资料，来自厂商的技术支持或者使用者的心得体会等，其内容可能存在描述上的差异，建议读者做出适当判断。
- 4.如需与我们联系，请发邮件到marketing@iczoom.com，主题请标有“数据手册”字样。

Read Statement

1. The datasheets and other product information on the site are all from network reference or other public materials, and the copyright belongs to the original author and original published source. If readers and copyright owners have any objections, please contact us and we will deal with it in a timely manner.
2. The Chinese datasheets provided on the website is a Chinese translation of the English datasheets. Its purpose is for reader's learning exchange only and do not involve commercial purposes. The translation cannot be automatically updated with the original manuscript, and there may also be improper translations. Readers are advised to use the English manuscript as a reference for more accurate information.
3. All product information provided on the website refer to solutions from manufacturers' technical support or users the contents may have differences in description, and readers are advised to take the original article as the standard.
4. If you have any questions, please contact us at marketing@iczoom.com and mark the subject with "Datasheets" .



AK4432

108dB 192kHz 32bit 2-Channel Audio DAC

1. General Description

The AK4432 is a 32-bit Stereo DAC which corresponds to digital audio systems. An internal circuit includes newly developed 32-bit Digital Filter achieving short group delay and high quality sound. The AK4432 has single end SCF outputs, increasing performance for systems with excessive clock jitter. The AK4432 is ideal for a wide range of applications that demands high sound quality including Home Theater and Car audio surround systems. It is housed in a 16-pin TSSOP package, saving more board space.

2. Features

1. 2ch 32bit DAC

- 128 times Oversampling
- 32-bit High Quality Sound Low Group Delay Digital Filter
- Single Ended Output, Smoothing Filter
- THD+N: 91dB
- DR, S/N: 108dB
- Channel Isolation Digital Volume (12dB~-115dB, 0.5dB Step, Mute)
- Soft Mute
- De-emphasis Filter (32kHz, 44.1kHz, 48kHz)
- I/F Format: MSB justified, LSB justified, I²S, TDM
- Zero Detection

2. Sampling Frequency

- Normal Speed Mode: 8kHz to 48kHz
- Double Speed Mode: 64kHz to 96kHz
- Quad Speed Mode: 128kHz to 192kHz

3. Master Clock

- | | |
|------------------------------|---------------------------------------|
| 256fs, 384fs, 512fs or 768fs | (Normal Speed Mode: fs=8kHz ~ 48kHz) |
| 256fs or 384fs | (Double Speed Mode: fs=48kHz ~ 96kHz) |
| 128fs or 192fs | (Quad Speed Mode: fs=96kHz ~ 192kHz) |

4. μ P Interface: 3-wire Serial (7MHz max)/ I²C bus (400kHz Mode, 1MHz Mode)

5. Power Supply

- Analog: AVDD = 3.0 ~ 3.6V
- Input/Output Buffer: LVDD = 3.0 ~ 3.6V
- Integrated LDO for Digital Power Supply

6. Power Consumptions: 7.8mA (fs=48kHz)

7. Operational Temperature: Ta = - 40 ~ 105°C

8. Package: 16-pin TSSOP (0.65mm pitch)

3. Table of Contents

1. General Description	1
2. Features	1
3. Table of Contents	2
4. Block Diagram	3
■ Block Diagram	3
■ Compatibility with AK4438, AK4452 and AK4458	4
5. Pin Configurations and Functions	5
■ Ordering Guide	5
■ Pin Layout	5
■ Pin Functions	6
■ Handling of Unused Pin	6
6. Absolute Maximum Ratings	7
7. Recommended Operation Conditions	7
8. Analog Characteristics	8
9. Filter Characteristics (fs=48kHz)	9
■ Sharp Roll-Off Filter (DASD bit = "0", DASL bit = "0")	9
■ Slow Roll-Off Filter (DASD bit = "0", DASL bit = "1")	10
■ Short Delay Sharp Roll-Off Filter (DASD bit = "1", DASL bit = "0")	11
■ Short Delay Slow Roll-Off Filter (DASD bit = "1", DASL bit = "1")	12
10. DC Characteristics	13
11. Switching Characteristics	14
■ Timing Diagram	17
12. Functional Descriptions	21
■ System Clock	21
■ Audio Interface Format	23
■ Digital Volume Function	30
■ Soft Mute Operation	31
■ Error Detection	32
■ System Reset	32
■ Power Down Function	33
■ Power Off and Reset Functions	34
■ Clock Synchronization	35
■ Parallel Mode	36
■ Audio Interface	36
■ Soft Mute	36
■ System Clock	36
■ Serial Control Interface	37
■ Register Map	43
■ Register Definitions	44
13. Recommended External Circuits	46
14. Package	48
■ Outline Dimensions	48
■ Material & Lead Finish	48
■ Marking	49
15. Revision History	49
IMPORTANT NOTICE	50

4. Block Diagram

■ Block Diagram

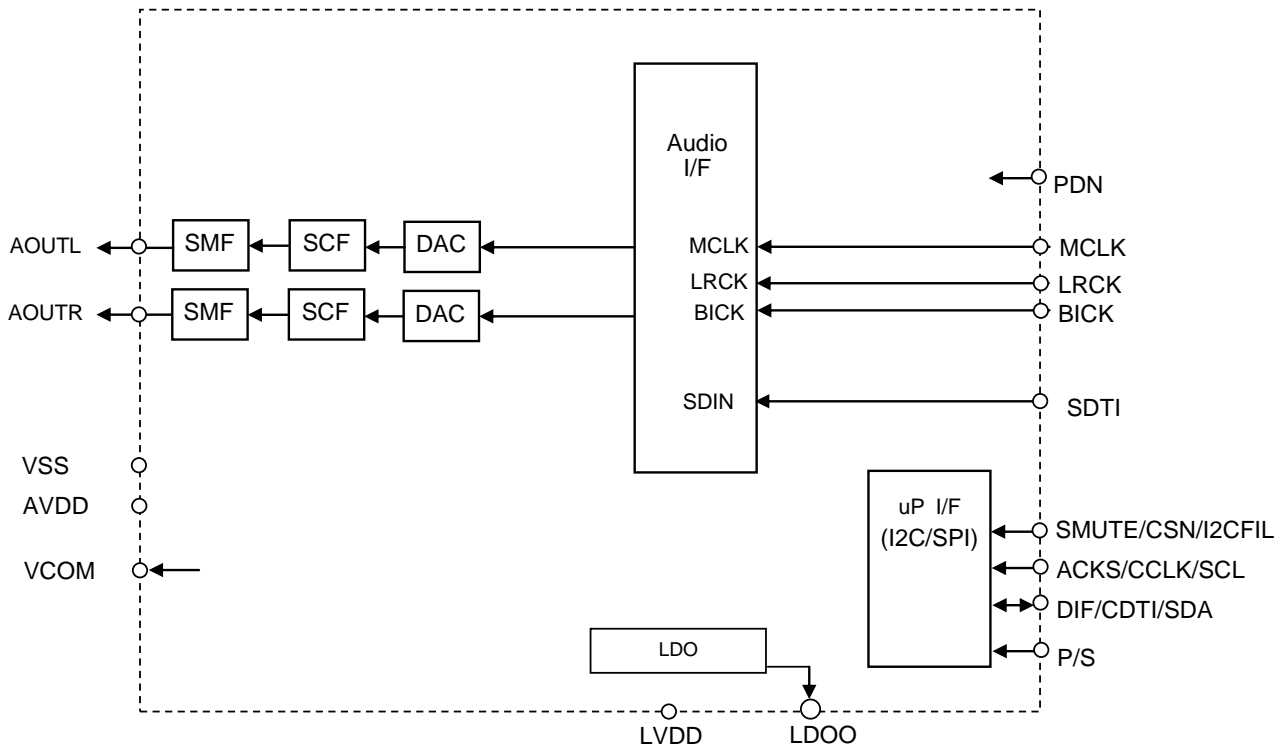

Figure 1. Block Diagram

■Compatibility with AK4438, AK4452 and AK4458

	AK4432	AK4436 / 38	AK4452 / 54 / 56 / 58
Channel	2ch	6ch / 8ch	2ch / 4ch / 6ch / 8ch
fs	8k to 192kHz	8k to 768kHz	8k to 768kHz
S/(N+D)	91dB	91dB	107dB
DR	108dB	108dB	115dB
AVDD (Analog Supply)	3.0 to 3.6V	3.0 to 3.6V	3.0 to 5.5V
TVDD or LVDD (I/O Buffer)	3.0 to 3.6V	1.7 to 3.6V	1.7 to 3.6V
Digital Filter	SA(Sharp)	69.9dB	80dB
	GD(Sharp)	26.4/fs	26.8/fs
	GD (SD Slow)	5.2/fs	4.8/fs
	Super Slow Roll-off	No	Yes
OSR Doubler (Over Sampling)	No (128x)	Yes (256x)	Yes (256x)
Zero Detection	No	Yes	Yes
Digital Volume	+12 to -115.0dB	+0 to -127.0dB	+0 to -127.0dB
ATT Speed (*Default)	1020/fs (*) 4080	4080/fs (*) 2040、510、255	4080/fs (*) 2040、510、255
LR Ch Output Select	No	Yes	Yes
Reset Function (MCLK detect)	No	Yes	Yes
Clock Synchronization	Yes (Note)	Yes	Yes
Package	16-pin TSSOP	32-pin QFN	AK4452/54: 32-pin QFN AK4456/58: 48-pin QFN

Note. MSB justified and 32-bit I²S compatible formats are available for audio interface but LSB justified format is not available.

5. Pin Configurations and Functions

■ **Ordering Guide**

AK4432VT	-40 ~ +105°C	16-pin TSSOP (0.65mm pitch)
AKD4432	Evaluation Board for the AK4432	

■ **Pin Layout**

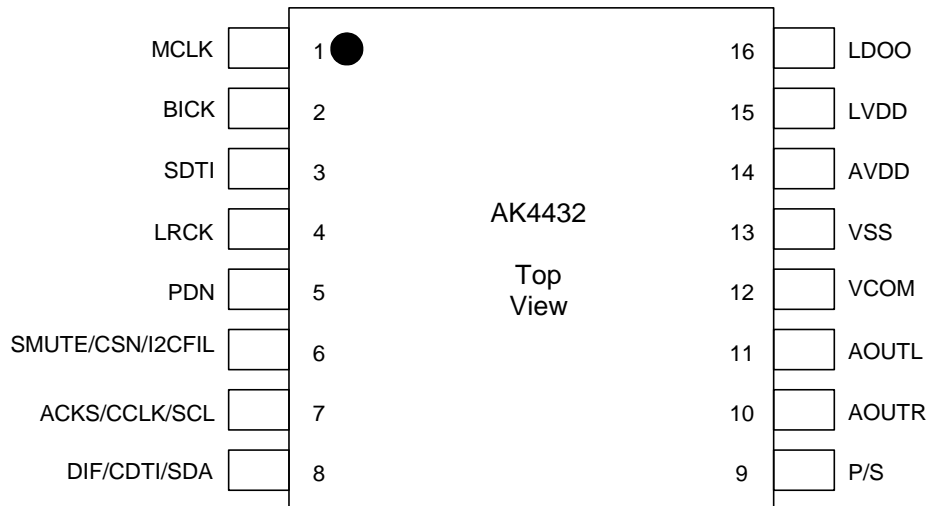

Figure 2. Pin Layout

■ Pin Functions

No.	Pin Name	I/O	PD state	Function
1	MCLK	I	-	External Master Clock Input Pin
2	BICK	I	-	Audio Serial Data Clock Pin
3	SDTI	I	-	Audio Serial Data Input
4	LRCK	I	-	Input Channel Clock Pin
5	PDN	I	-	Power-Down & Reset Pin When "L", the AK4432 is powered-down and the control registers are reset to default state.
6	SMUTE	I	-	Soft Mute Pin in Parallel control mode. When this pin is changed to "H", soft mute cycle is initiated. When returning "L", the output mute releases.
	CSN	I		Chip Select Pin in 3-wire serial control mode
	I2CFIL	I		I2C Interface Mode Select Pin "L": Fast Mode (400kHz), "H": Fast Mode Plus (1MHz). Do not change this pin during PDN pin = "H".
7	ACKS	I	-	Auto Setting Mode in Parallel control mode "L": Manual Setting Mode, "H": Auto Setting Mode
	CCLK	I		Control Data Clock Pin in 3-wire serial control mode
	SCL	I		Control Data Clock Pin in I2C Bus serial control mode
8	DIF	I	-	Audio Data Format Select in Parallel control mode. "L": 32bit MSB, "H": 32bit I2S
	CDTI	I		Control Data Input Pin in 3-wire serial control mode
	SDA	I/O		Control Data Input Pin in I2C Bus serial control mode
9	P/S	I	-	Parallel/Serial Mode Select Pin "L": Serial Mode, "H": Parallel Mode Do not change this pin during PDN pin = "H".
10	AOUTR	O	Hi-z	Rch Analog Output Pin
11	AOUTL	O	Hi-z	Lch Analog Output Pin
12	VCOM	O	500ohm Pull-down	Common Voltage Output Pin, AVDDx1/2 Large external capacitor around 2.2μF is used to reduce power-supply noise.
13	VSS	-	-	Ground Pin
14	AVDD	-	-	Analog Power Supply Pin, 3.0V~3.6V
15	LVDD	-	-	LDO Power Supply / Digital I/F Power Supply Pin, 3.0V~3.6V
16	LDOO	O	580ohm Pull-down	LDO Output Pin This pin should be connected to ground with 1.0uF.

Note 1. All digital input pins must not be allowed to float.

■ Handling of Unused Pin

Unused I/O pins must be connected appropriately.

Classification	Pin Name	Setting
Analog	AOUTL, AOUTR	Open

6. Absolute Maximum Ratings

(VSS = 0V; [Note 2](#))

Parameter	Symbol	Min.	Max.	Unit
Power Supply	AVDD	-0.3	4.3	V
Power Supply	LVDD	-0.3	4.3	V
Input Current (any pins except for supplies)	IIN	-	±10	mA
Input Voltage (Note 3)	VIN	-0.3	(LVDD+0.3) or 4.3	V
Ambient Temperature (power applied)	Ta	-40	105	°C
Storage Temperature	Tstg	-65	150	°C

Note 2. All voltages with respect to ground. VSS must be connected to the same analog ground plane.

Note 3. The maximum Digital input voltage is smaller value between (LVDD+0.3)V and 4.3V.

WARNING: Operation at or beyond these limits may result in permanent damage to the device.
Normal operation is not guaranteed at these extremes.

7. Recommended Operation Conditions

(VSS=0V; [Note 2](#))

Parameter		Symbol	Min.	Typ.	Max.	Unit
Power Supplies	Analog	AVDD	3.0	3.3	3.6	V
	LDO, Digital (I/F)	LVDD	3.0	3.3	3.6	V

Note 4. Do not turn off the power supply of the AK4432 with the power supply of the peripheral device turned on. When using the I²C interface, pull-up resistors of SDA and SCL pins should be connected to LVDD or less voltage.

* AKM assumes no responsibility for the usage beyond the conditions in this data sheet.

8. Analog Characteristics

(Ta=25°C; AVDD = LVDD=3.3V; VSS =0V; fs=48kHz, 96kHz, 192kHz; BICK=64fs; Signal Frequency=1kHz; 32bit Data; Measurement Frequency=20Hz~20kHz at fs=48kHz, 20Hz~40kHz at fs=96kHz, 20Hz~40kHz at fs=192kHz, unless otherwise specified.)

Parameter	Min.	Typ.	Max.	Unit
DAC Analog Output Characteristics				
Resolution			32	bit
Output Voltage (Note 5)	2.55	2.83	3.11	Vpp
S/(N+D) (0dBFS)	fs=48kHz	80	91	dB
	fs=96kHz		89	dB
	fs=192kHz		89	dB
Dynamic Range (-60dBFS)	fs=48kHz (A-weighted)		108	dB
	fs=96kHz		101	
	fs=192kHz		101	
S/N	fs=48kHz (A-weighted)		108	dB
	fs=96kHz		101	
	fs=192kHz		101	
Interchannel Isolation	90	110		dB
Interchannel Gain Mismatch		0	0.7	dB
Load Resistance (Note 6)	10			kΩ
Load Capacitance			30	pF

Note 5. Full-scale output voltage. The output voltage is always proportional to AVDD (AVDD x 0.86).

Note 6. AC Load

Parameter	Min.	Typ.	Max.	Unit
Power Supplies				
Power Supply Current				
Normal Operation (PDN pin = "H")				
AVDD		6.5	9.0	mA
LVDD	fs=48kHz, 96kHz, 192kHz	1.3	2	mA
	fs=48kHz	1.6	2.5	mA
	fs=96kHz	2.1	3.0	mA
Power-down mode (PDN pin = "L") (Note 7)		10	200	μA

Note 7. Quiescent Current. All digital input pins including clock pins are fixed to VSS.

9. Filter Characteristics (fs=48kHz)

(Ta= -40 ~ +105°C; AVDD =3.0~ 3.6V, LVDD=3.0~ 3.6V; DEM=OFF)

■ Sharp Roll-Off Filter (DASD bit = “0”, DASL bit = “0”)

fs=48kHz

Parameter		Symbol	Min.	Typ.	Max.	Unit
Passband (Note 8)	-0.08dB~+0.08dB	PB	0	-	22.2	kHz
	-6.0dB	PB	-	23.99	-	kHz
Passband Ripple		PR	-0.08		+0.08	dB
Stopband (Note 8)		SB	26.2			kHz
Stopband Attenuation		SA	69.9			dB
Group Delay (Note 9)		GD	-	26.4	-	1/fs
Digital Filter + SCF + SMF						
Frequency Response: 0Hz ~ 20kHz		FR	-0.20		-0.10	dB

fs=96kHz

Parameter		Symbol	Min.	Typ.	Max.	Unit
Passband (Note 8)	-0.08dB~+0.08dB	PB	0	-	44.4	kHz
	-6.0dB	PB	-	48.00	-	kHz
Passband Ripple		PR	-0.08		+0.08	dB
Stopband (Note 8)		SB	52.5			kHz
Stopband Attenuation		SA	69.8			dB
Group Delay (Note 9)		GD	-	26.4	-	1/fs
Digital Filter + SCF + SMF						
Frequency Response: 0Hz ~ 40kHz		FR	-0.50		-0.10	dB

fs=192kHz

Parameter		Symbol	Min.	Typ.	Max.	Unit
Passband (Note 8)	-0.08dB~+0.08dB	PB	0	-	88.8	kHz
	-6.0dB	PB	-	96.00	-	kHz
Passband Ripple		PR	-0.08		+0.08	dB
Stopband (Note 8)		SB	104.9			kHz
Stopband Attenuation		SA	69.8			dB
Group Delay (Note 9)		GD	-	26.4	-	1/fs
Digital Filter + SCF + SMF						
Frequency Response: 0Hz ~ 80kHz		FR	-2.00		0.00	dB

■ Slow Roll-Off Filter (DASD bit = “0”, DASL bit = “1”)

fs=48kHz

Parameter		Symbol	Min.	Typ.	Max.	Unit
Passband (Note 8)	-0.07dB~+0.021dB	PB	0	-	9.0	kHz
	-3.0dB	PB	-	19.75	-	kHz
Passband Ripple		PR	-0.07		+0.021	dB
Stopband (Note 8)		SB	42.6			kHz
Stopband Attenuation		SA	72.6			dB
Group Delay (Note 9)		GD	-	26.4	-	1/fs
Digital Filter + SCF + SMF						
Frequency Response: 0Hz ~ 20kHz		FR	-3.75		-2.75	dB

fs=96kHz

Parameter		Symbol	Min.	Typ.	Max.	Unit
Passband (Note 8)	-0.07dB~+0.023dB	PB	0	-	18.1	kHz
	-3.0dB	PB	-	39.6	-	kHz
Passband Ripple		PR	-0.07		+0.023	dB
Stopband (Note 8)		SB	85.1			kHz
Stopband Attenuation		SA	72.6			dB
Group Delay (Note 9)		GD	-	26.4	-	1/fs
Digital Filter + SCF + SMF						
Frequency Response: 0Hz ~ 40kHz		FR	-4.25		-2.75	dB

fs=192kHz

Parameter		Symbol	Min.	Typ.	Max.	Unit
Passband (Note 8)	-0.07dB~+0.023dB	PB	0	-	36.1	kHz
	-3.0dB	PB	-	79.3	-	kHz
Passband Ripple		PR	-0.07		+0.023	dB
Stopband (Note 8)		SB	170.3			kHz
Stopband Attenuation		SA	72.6			dB
Group Delay (Note 9)		GD	-	26.4	-	1/fs
Digital Filter + SCF + SMF						
Frequency Response: 0Hz ~ 80kHz		FR	-5.00		-3.00	dB

■ Short Delay Sharp Roll-Off Filter (DASD bit = “1”, DASL bit = “0”)

fs=48kHz

Parameter		Symbol	Min.	Typ.	Max.	Unit
Passband (Note 8)	-0.07dB~+0.07dB	PB	0	-	22.0	kHz
	-6.0dB	PB	-	24.11	-	kHz
Passband Ripple		PR	-0.07		+0.07	dB
Stopband (Note 8)		SB	26.2			kHz
Stopband Attenuation		SA	56.6			dB
Group Delay (Note 9)		GD	-	5.9	-	1/fs
Digital Filter + SCF + SMF						
Frequency Response: 0Hz ~ 20kHz		FR	-0.20		-0.10	dB

fs=96kHz

Parameter		Symbol	Min.	Typ.	Max.	Unit
Passband (Note 8)	-0.08dB~+0.08dB	PB	0	-	44.3	kHz
	-6.0dB	PB	-	48.25	-	kHz
Passband Ripple		PR	-0.08		+0.08	dB
Stopband (Note 8)		SB	52.5			kHz
Stopband Attenuation		SA	56.4			dB
Group Delay (Note 9)		GD	-	5.9	-	1/fs
Digital Filter + SCF + SMF						
Frequency Response: 0Hz ~ 40kHz		FR	-0.50		-0.10	dB

fs=192kHz

Parameter		Symbol	Min.	Typ.	Max.	Unit
Passband (Note 8)	-0.08dB~+0.08dB	PB	0	-	88.6	kHz
	-6.0dB	PB	-	96.50	-	kHz
Passband Ripple		PR	-0.08		+0.08	dB
Stopband (Note 8)		SB	104.9			kHz
Stopband Attenuation		SA	56.4			dB
Group Delay (Note 9)		GD	-	5.9	-	1/fs
Digital Filter + SCF + SMF						
Frequency Response: 0Hz ~ 80kHz		FR	-2.00		0.00	dB

■ Short Delay Slow Roll-Off Filter (DASD bit = “1”, DASL bit = “1”)

fs=48kHz

Parameter		Symbol	Min.	Typ.	Max.	Unit
Passband (Note 8)	-0.07dB~+0.05dB	PB	0	-	10.1	kHz
	-3.0dB	PB	-	20.24	-	kHz
Passband Ripple		PR	-0.07		+0.05	dB
Stopband (Note 8)		SB	43.0			kHz
Stopband Attenuation		SA	74.9			dB
Group Delay (Note 9)		GD	-	5.2	-	1/fs
Digital Filter + SCF + SMF						
Frequency Response: 0Hz ~ 20kHz		FR	-3.50		-2.50	dB

fs=96kHz

Parameter		Symbol	Min.	Typ.	Max.	Unit
Passband (Note 8)	-0.07dB~+0.05dB	PB	0	-	20.3	kHz
	-3.0dB	PB	-	40.50	-	kHz
Passband Ripple		PR	-0.07		+0.05	dB
Stopband (Note 8)		SB	86.0			kHz
Stopband Attenuation		SA	74.9			dB
Group Delay (Note 9)		GD	-	5.2	-	1/fs
Digital Filter + SCF + SMF						
Frequency Response: 0Hz ~ 40kHz		FR	-4.00		-2.50	dB

fs=192kHz

Parameter		Symbol	Min.	Typ.	Max.	Unit
Passband (Note 8)	-0.07dB~+0.05dB	PB	0	-	40.6	kHz
	-3.0dB	PB	-	81.00	-	kHz
Passband Ripple		PR	-0.07		+0.05	dB
Stopband (Note 8)		SB	172.0			kHz
Stopband Attenuation		SA	74.9			dB
Group Delay (Note 9)		GD	-	5.2	-	1/fs
Digital Filter + SCF + SMF						
Frequency Response: 0Hz ~ 80kHz		FR	-4.75		-2.75	dB

Note 8. The passband and stopband frequencies are proportional to “fs” (system sampling rate). Each frequency response refers to that of 1kHz.

Note 9. The calculated delay time caused by digital filtering. The digital filter’s delay is calculated as the time from setting 16/24/32bit impulse data into the input register until an analog peak signal is output.

10. DC Characteristics

(Ta= -40 ~ +105°C; AVDD =3.0~ 3.6V, LVDD =3.0~ 3.6V, VSS=0V)

Parameter	Symbol	Min.	Typ.	Max.	Unit
All digital input pins except SCL and SDA pins					
High-Level Input Voltage	VIH1	80%LVDD	-	-	V
Low-Level Input Voltage	VIL1	-	-	20%LVDD	V
SCL, SDA Pin					
High-Level Input Voltage	VIH2	70%LVDD	-	-	V
Low-Level Input Voltage	VIL2	-	-	30%LVDD	V
SDA Pin					
Low-Level Output Voltage					
Fast Mode (Iout= 3mA)	VOL1	-		0.4	V
Fast Mode Plus (Iout= 20mA)	VOL2	-		0.4	V
Input Leakage Current	Iin	-	-	±10	μA

11. Switching Characteristics

(Ta=-40 ~ 105°C; AVDD=LVDD=3.0 ~ 3.6V; CL=20pF, unless otherwise specified)

Parameter	Symbol	Min.	Typ.	Max.	Unit
Master Clock Timing					
External Clock					
256fsn:	fCLK	2.048		12.288	MHz
Pulse Width Low	tCLKL	32			ns
Pulse Width High	tCLKH	32			ns
384fsn:	fCLK	3.072		18.432	MHz
Pulse Width Low	tCLKL	22			ns
Pulse Width High	tCLKH	22			ns
512fsn, 256fsd, 128fsq:	fCLK	4.096		24.576	MHz
Pulse Width Low	tCLKL	16			ns
Pulse Width High	tCLKH	16			ns
768fsn, 384fsd, 192fsq:	fCLK	16.384		36.864	MHz
Pulse Width Low	tCLKL	11			ns
Pulse Width High	tCLKH	11			ns
LRCK Timing (Slave Mode)					
Stereo mode (TDM1-0 bits = "00")					
Normal Speed Mode	fsn	8		48	kHz
Double Speed Mode	fsd	48		96	kHz
Quad Speed Mode	fsq	96		192	kHz
Duty Cycle	Duty	-	50	-	%
TDM128 mode (TDM1-0 bits = "01")					
LRCK frequency	fsn	8		48	kHz
	fsd	48		96	kHz
	fsq	96		192	kHz
I ² S compatible: Pulse Width Low	tLRL	1/(128fsq)		127/(128fsq)	s
MSB or LSB justified: Pulse Width High	tLRH	1/(128fsq)		127/(128fsq)	s
TDM256 mode (TDM1-0 bits = "10")					
LRCK frequency	fsn	8		48	kHz
	fsd	48		96	kHz
I ² S compatible: Pulse Width Low	tLRL	1/(256fsd)		255/(256fsd)	s
MSB or LSB justified: Pulse Width High	tLRH	1/(256fsd)		255/(256fsd)	s

Parameter	Symbol	Min.	Typ.	Max.	Unit
Audio Interface Timing					
Normal Mode (TDM1-0 bits = "00")					
BICK Period					
Normal Speed Mode	tBCK	1/256fsn			ns
Double Speed Mode	tBCK	1/256fsd			ns
Quad Speed Mode	tBCK	1/128fsq			ns
BICK Pulse Width Low	tBCKL	18			ns
BICK Pulse Width High	tBCKH	18			ns
BICK "↑" to LRCK Edge (Note 10)	tBLR	5			ns
LRCK Edge to BICK "↑" (Note 10)	tLRB	5			ns
SDTI Hold Time	tSDH	5			ns
SDTI Setup Time	tSDS	5			ns
TDM128 mode (TDM1-0 bits = "01")					
BICK Period					
Normal Speed Mode	tBCK	1/128fsn			ns
Double Speed Mode	tBCK	1/128fsd			ns
Quad Speed Mode	tBCK	1/128fsq			ns
BICK Pulse Width Low	tBCKL	18			ns
BICK Pulse Width High	tBCKH	18			ns
BICK "↑" to LRCK Edge (Note 10)	tBLR	5			ns
LRCK Edge to BICK "↑" (Note 10)	tLRB	5			ns
SDTI Hold Time	tSDH	5			ns
SDTI Setup Time	tSDS	5			ns
TDM256 mode (TDM1-0 bits = "10")					
BICK Period					
Normal Speed Mode	tBCK	1/256fsn			ns
Double Speed Mode	tBCK	1/256fsd			ns
BICK Pulse Width Low	tBCKL	18			ns
BICK Pulse Width High	tBCKH	18			ns
BICK "↑" to LRCK Edge (Note 10)	tBLR	5			ns
LRCK Edge to BICK "↑" (Note 10)	tLRB	5			ns
SDTI Hold Time	tSDH	5			ns
SDTI Setup Time	tSDS	5			ns

Note 10. BICK rising edge must not occur at the same time as LRCK edge.

Parameter	Symbol	Min.	Typ.	Max.	Unit
Control Interface Timing (3-wire Serial mode):					
CCLK frequency	fCCK			7	MHz
CCLK Pulse Width Low	tCCKL	60			ns
Pulse Width High	tCCKH	60			ns
CDTI Setup Time	tCDS	60			ns
CDTI Hold Time	tCDH	60			ns
CSN “H” Time	tCSW	150			ns
CSN “↓” to CCLK “↓”	tCSS	150			ns
CCLK “↑” to CSN “↑”	tCSH	240			ns
Control Interface Timing (I²C Fast mode):					
SCL Clock Frequency	fSCL	-		400	kHz
Bus Free Time Between Transmissions	tBUF	1.3		-	μs
Start Condition Hold Time (prior to first clock pulse)	tHD:STA	0.6		-	μs
Clock Low Time	tLOW	1.3		-	μs
Clock High Time	tHIGH	0.6		-	μs
Setup Time for Repeated Start Condition	tSU:STA	0.6		-	μs
SDA Hold Time from SCL Falling (Note 11)	tHD:DAT	0		-	μs
SDA Setup Time from SCL Rising	tSU:DAT	0.1		-	μs
Rise Time of Both SDA and SCL Lines	tR	-		1.0	μs
Fall Time of Both SDA and SCL Lines	tF	-		0.3	μs
Setup Time for Stop Condition	tSU:STO	0.6		-	μs
Pulse Width of Spike Noise Suppressed by Input Filter	tSP	0		50	ns
Capacitive load on bus	Cb	-		400	pF
Control Interface Timing (I²C Fast mode Plus):					
SCL Clock Frequency	fSCL	-		1	MHz
Bus Free Time Between Transmissions	tBUF	0.5		-	μs
Start Condition Hold Time (prior to first clock pulse)	tHD:STA	0.26		-	μs
Clock Low Time	tLOW	0.5		-	μs
Clock High Time	tHIGH	0.26		-	μs
Setup Time for Repeated Start Condition	tSU:STA	0.26		-	μs
SDA Hold Time from SCL Falling (Note 12)	tHD:DAT	0		-	μs
SDA Setup Time from SCL Rising	tSU:DAT	0.05		-	μs
Rise Time of Both SDA and SCL Lines	tR	-		0.12	μs
Fall Time of Both SDA and SCL Lines	tF	-		0.12	μs
Setup Time for Stop Condition	tSU:STO	0.26		-	μs
Pulse Width of Spike Noise Suppressed by Input Filter	tSP	0		50	ns
Capacitive load on bus	Cb	-		550	pF
Power-down & Reset Timing					
PDN Pulse Width (Note 13)	tPD	800			ns

Note 11. Data must be held for sufficient time to bridge the 300 ns transition time of SCL.

Note 12. Data must be held for sufficient time to bridge the 120ns transition time of SCL.

Note 13. The AK4432 can be reset by setting the PDN pin to “L” upon power-up. The PDN pin must held “L” for more than 800ns for a certain reset. The AK4432 is not reset by the “L” pulse less than 50ns.

Note 14. I²C is a trademark of NXP B.V.

■ Timing Diagram

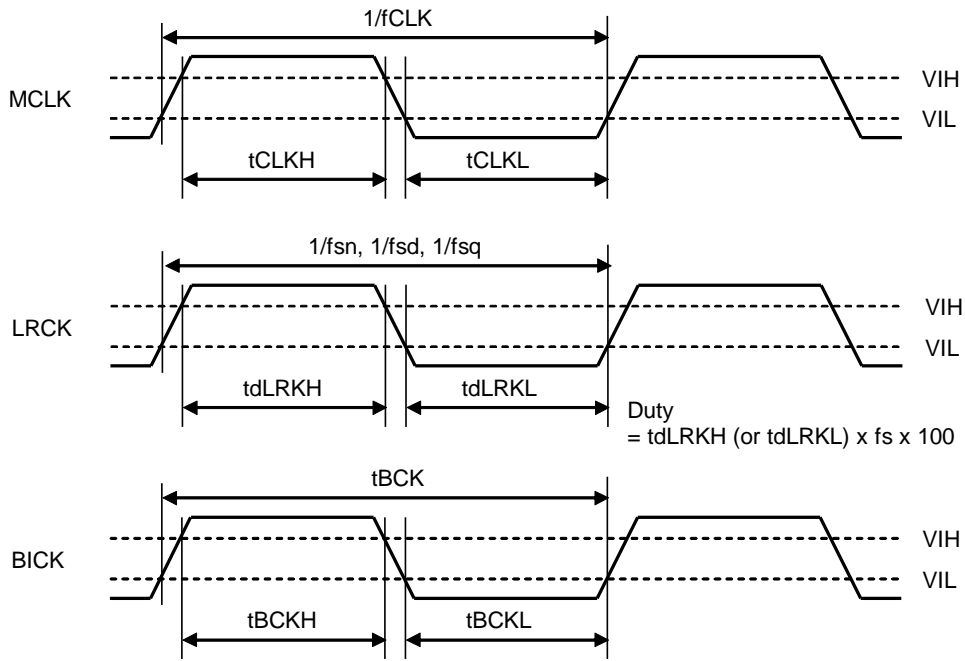

Figure 3. Clock Timing (TDM1-0 bits = "00")

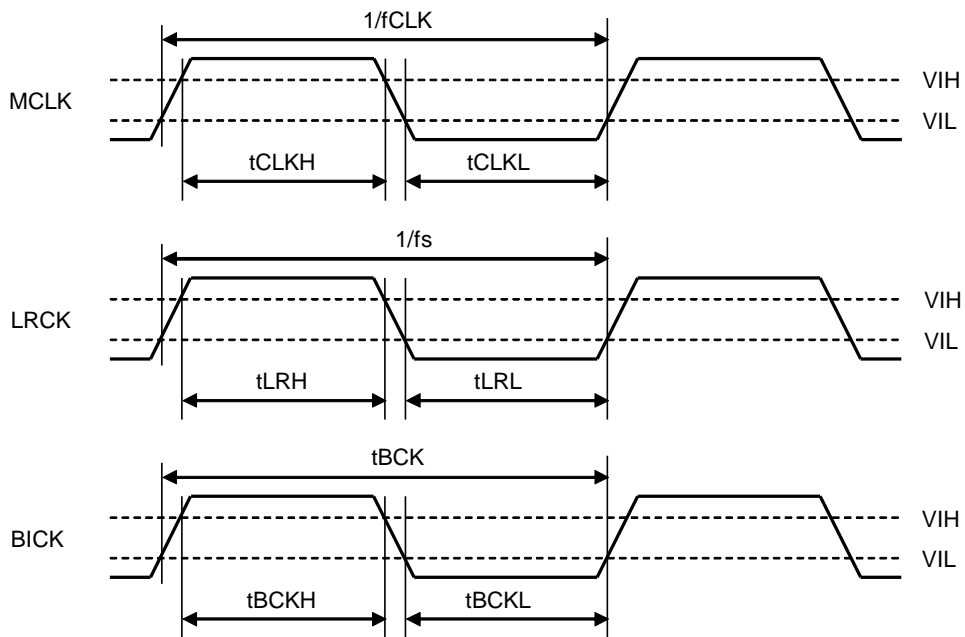

Figure 4. Clock Timing (Except TDM1-0 bits = "00")

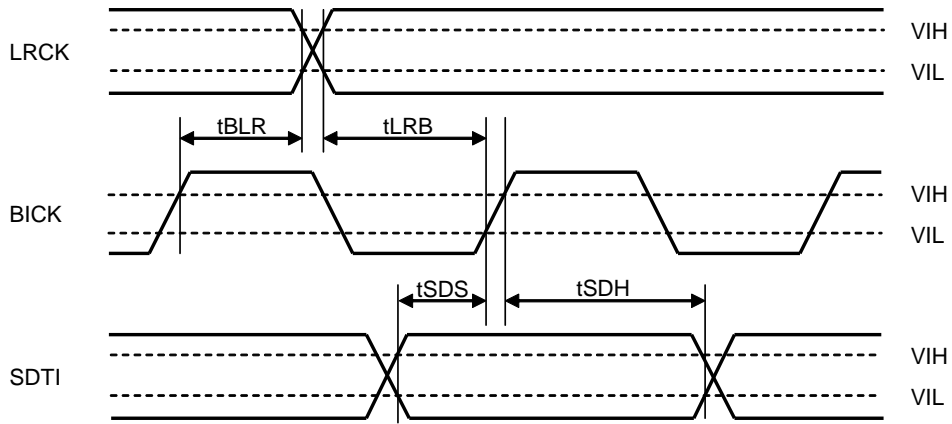

Figure 5. Audio Interface Timing (TDM1-0 bits = "00")

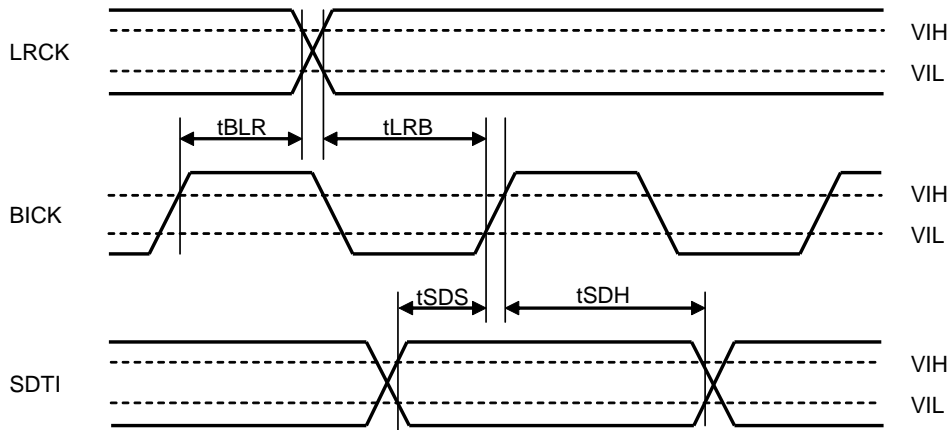

Figure 6. Audio Interface Timing (Except TDM1-0 bits = "00")

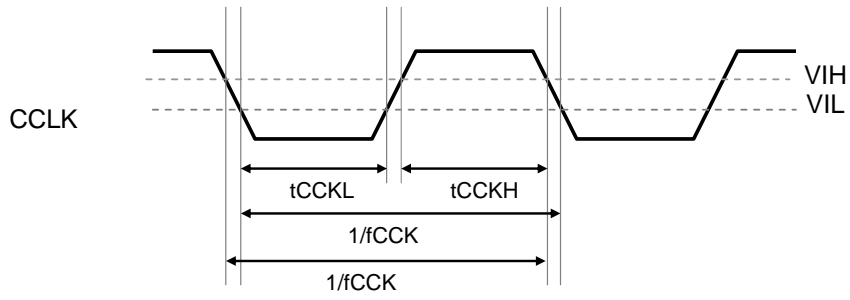

Figure 7. 3-wire Serial Mode Interface Timing

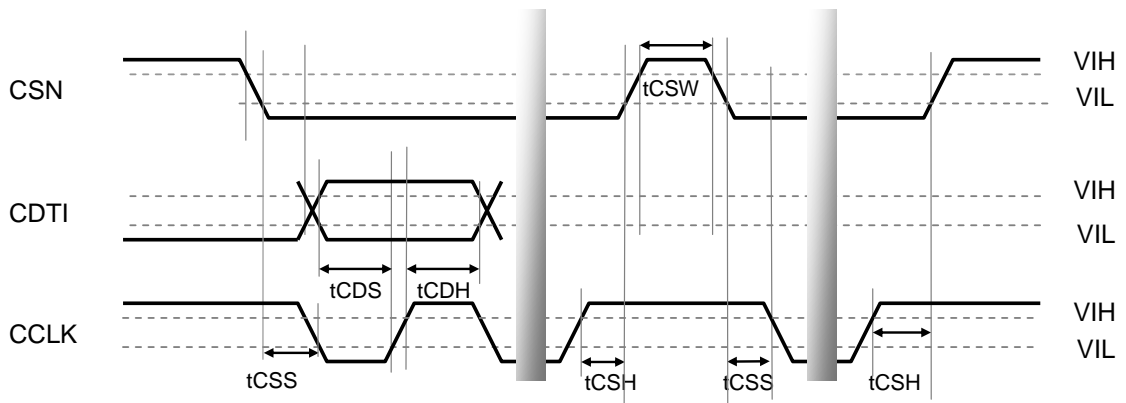

Figure 8. WRITE Data Input Timing (3-wire Serial mode)

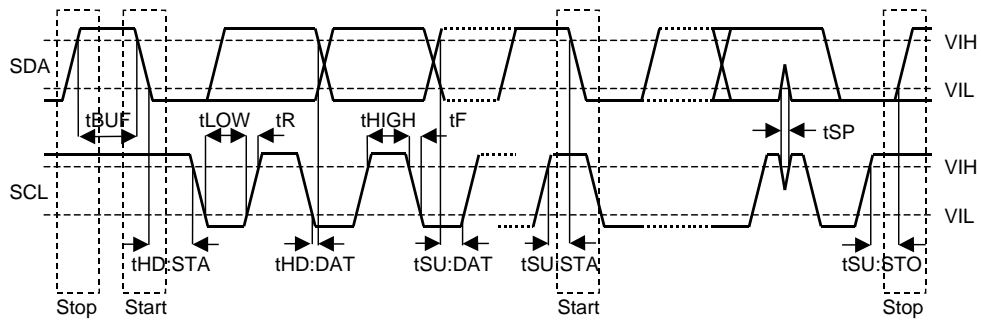

Figure 9. I²C Bus Mode Timing

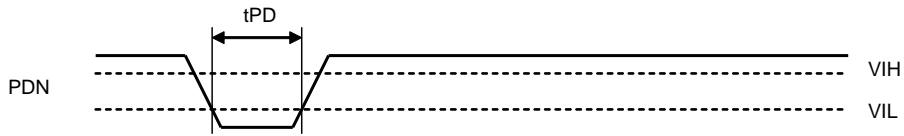

Figure 10. Power-down & Reset Timing

12. Functional Descriptions

■ System Clock

The external clocks which are required to operate the AK4432 are MCLK, LRCK and BICK. MCLK should be synchronized with LRCK and BICK but the phase is not critical. There are two methods to set MCLK frequency. In Manual Setting Mode (ACKS bit= "0": Default), the sampling speed is set by DFS0, DFS1 (Table 1). The frequency of MCLK at each sampling speed is set automatically (Table 2, Table 3, Table 4). In Auto Setting Mode (ACKS bit= "1"), as MCLK frequency is detected automatically (Table 5) and the internal master clock attains the appropriate frequency (Table 6), so it is not necessary to set DFS bits.

The AK4432 exits system reset (power-down mode) by inputting MCLK and LRCK after the PDN pin="H".

If the clock is stopped, a click noise occurs when restarting the clock. Mute the digital output externally if the click noise affects system applications.

DFS1	DFS0	Sampling Speed Mode (fs)	
0	0	Normal Speed Mode	8kHz~48kHz
0	1	Double Speed Mode	48kHz~96kHz
1	0	Quad Speed Mode	96kHz~192kHz
1	1	N/A	-

(default)

(N/A: Not available)

Table 1. Sampling Speed (Manual Setting Mode)

LRCK fs	MCLK (MHz)				BICK (MHz)
	256fs	384fs	512fs	768fs	
8.0kHz	2.0480	3.0720	4.0960	6.1440	0.512
44.1kHz	11.2896	16.9344	22.5792	33.8688	2.8224
48.0kHz	12.2880	18.4320	24.5760	36.8640	3.0720

Table 2. System Clock Example (Normal Speed Mode @Manual Setting Mode)

LRCK fs	MCLK (MHz)		BICK (MHz)
	256fs	384fs	
88.2kHz	22.5792	33.8688	5.6448
96.0kHz	24.5760	36.8640	6.1440

Table 3. System Clock Example (Double Speed Mode @Manual Setting Mode)

LRCK fs	MCLK (MHz)		BICK (MHz)
	128fs	192fs	
176.4kHz	22.5792	33.8688	11.2896
192.0kHz	24.5760	36.8640	12.2880

Table 4. System Clock Example (Quad Speed Mode @Manual Setting Mode)

MCLK		Sampling Speed Mode
512fs	768fs	Normal Speed Mode
256fs	384fs	Double Speed Mode
128fs	192fs	Quad Speed Mode

Table 5. Sampling Speed (Auto Setting Mode)

LRCK fs	MCLK (MHz)						Sampling Speed Mode
	128fs	192fs	256fs	384fs	512fs	768fs	
8.0kHz	-	-	-	-	4.0960	6.1440	Normal Speed Mode
44.1kHz	-	-	-	-	22.5792	33.8688	
48.0kHz	-	-	-	-	24.5760	36.8640	
88.2kHz	-	-	22.5792	33.8688	-	-	Double Speed Mode
96.0kHz	-	-	24.5760	36.8640	-	-	
176.4kHz	22.5792	33.8688	-	-	-	-	Quad Speed Mode
192.0kHz	24.5760	36.8640	-	-	-	-	

Table 6. System Clock Example (Auto Setting Mode)

■ Audio Interface Format

TDM1-0 bits, DIF2-0 bits, SDS2-0 bits, TDM1-0 pins and DIF pin settings should not be changed during operation. MSB justified and I²S formats are available but LSB justified format is not available when SYNCE bit = "1" (default).

Normal Mode (TDM1-0 bit="00")

Two channels audio data is shifted in via the SDTI pin using BICK and LRCK inputs. Eight data formats are supported and selected by the DIF2-0 bits as shown in [Table 7](#). In all formats the serial data is MSB first, 2's complement format and is latched on the rising edge of BICK. Input "0" data to unused bits if the data does not use maximum bits when MSB justified, I²S format is selected. (e.g. Mode2 can be used in 16-bit MSB justified by zeroing the unused 8bits LSB).

TDM128 Mode (TDM1-0 bit="01")

Four channels audio data is shifted in via the SDTI pin using BICK and LRCK inputs. Data is selected by SDS1-0 bits. BICK is fixed to 128fs. Six data formats are supported and selected by the DIF2-0 bits as shown in [Table 7](#). In all formats the serial data is MSB first, 2's complement format and is latched on the rising edge of BICK.

TDM256 Mode (TDM1-0 bit="1X")

Eight channels audio data is shifted in via the SDTI pin using BICK and LRCK inputs. Data is selected by SDS1-0 bits. BICK is fixed to 256fs. Six data formats are supported and selected by the DIF2-0 bits as shown in [Table 7](#). In all formats the serial data is MSB first, 2's complement format and is latched on the rising edge of BICK.

Mode		TDM1	TDM0	DIF2	DIF1	DIF0	SDTI Format	LRCK	BICK
Normal (Note 15)	0	0	0	0	0	0	16-bit LSB justified	H/L	≥32fs
	1			0	0	1	20-bit LSB justified	H/L	≥40fs
	2			0	1	0	24-bit MSB justified	H/L	≥48fs
	3			0	1	1	16-bit I ² S compatible	L/H	32fs
				24-bit I ² S compatible	L/H	≥48fs			
	4			1	0	0	24-bit LSB justified	H/L	≥48fs
	5			1	0	1	32-bit LSB justified	H/L	≥64fs
	6			1	1	0	32-bit MSB justified	H/L	≥64fs
7	1	1	1	32-bit I ² S compatible	L/H	≥64fs			
TDM128	-	0	1	0	0	0	N/A	↑	128fs
	-			0	0	1	N/A	↑	128fs
	8			0	1	0	24-bit MSB justified	↑	128fs
	9			0	1	1	24-bit I ² S compatible	↓	128fs
	10			1	0	0	24-bit LSB justified	↑	128fs
	11			1	0	1	32-bit LSB justified	↑	128fs
	12			1	1	0	32-bit MSB justified	↑	128fs
	13			1	1	1	32-bit I ² S compatible	↓	128fs
TDM256	-	1	0	0	0	0	N/A	↑	256fs
	-			0	0	1	N/A	↑	256fs
	14			0	1	0	24-bit MSB justified	↑	256fs
	15			0	1	1	24-bit I ² S compatible	↓	256fs
	16			1	0	0	24-bit LSB justified	↑	256fs
	17			1	0	1	32-bit LSB justified	↑	256fs
	18			1	1	0	32-bit MSB justified	↑	256fs
	19			1	1	1	32-bit I ² S compatible	↓	256fs

Note 15. BICK that is input to each channel must be longer than the bit length of setting format.

Table 7. Audio Data Format (N/A: Not available)

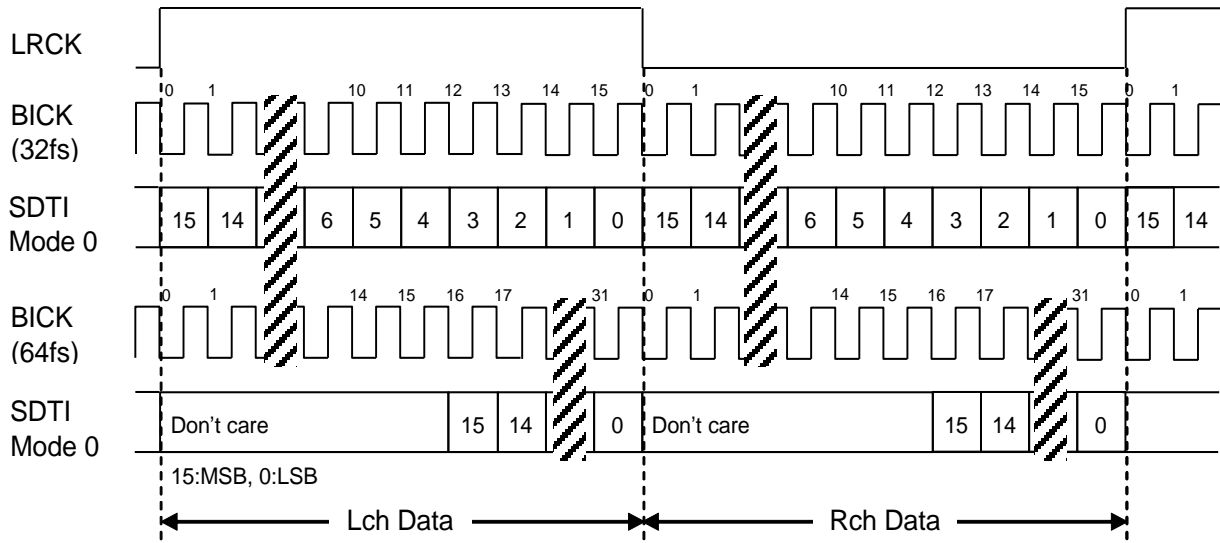

Figure 11. Mode 0 Timing

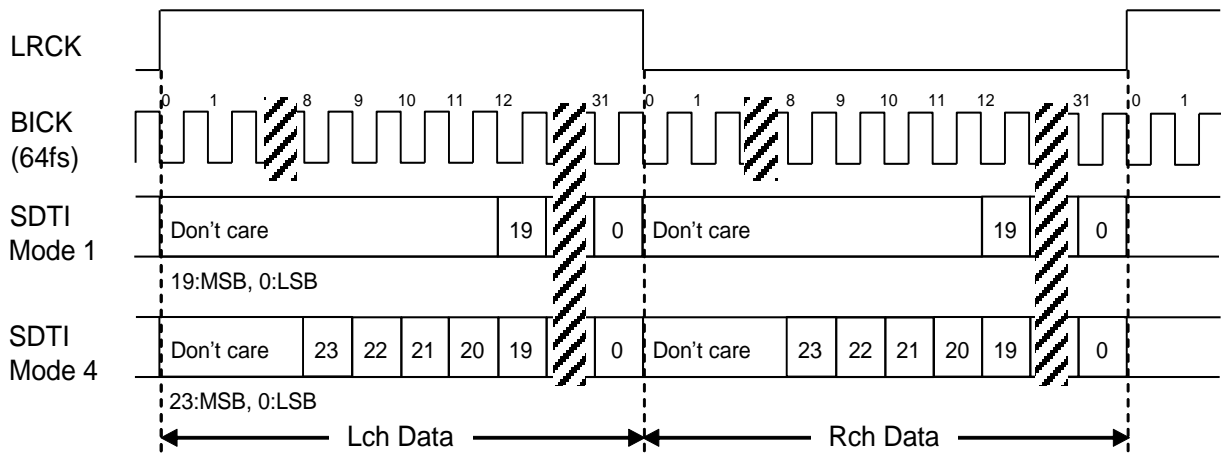

Figure 12. Mode 1/4 Timing

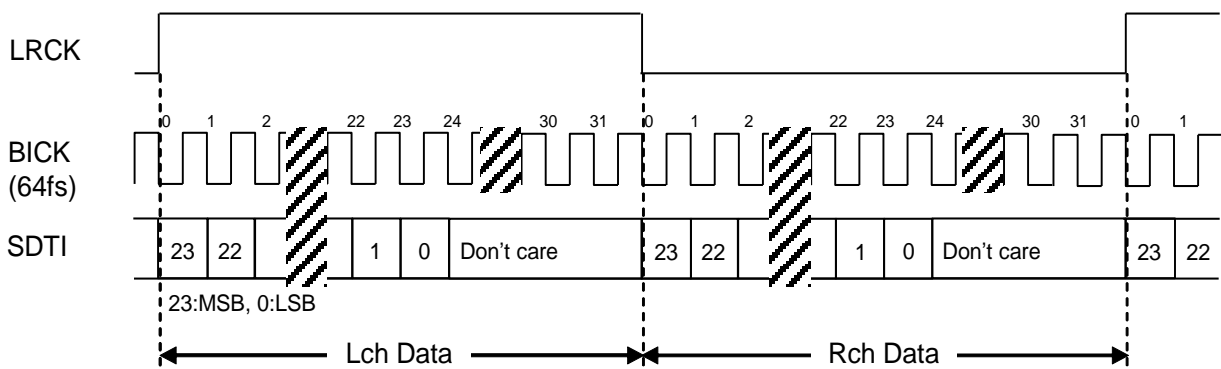

Figure 13. Mode 2 Timing

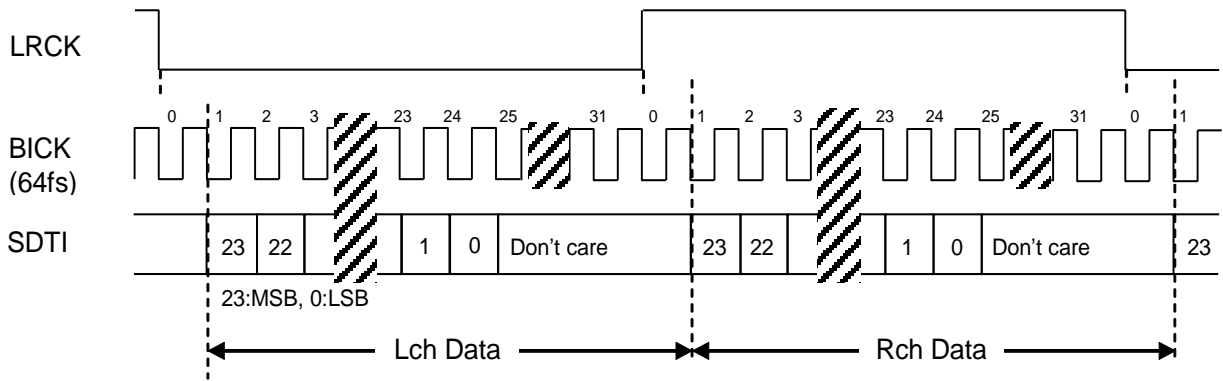

Figure 14. Mode 3 Timing

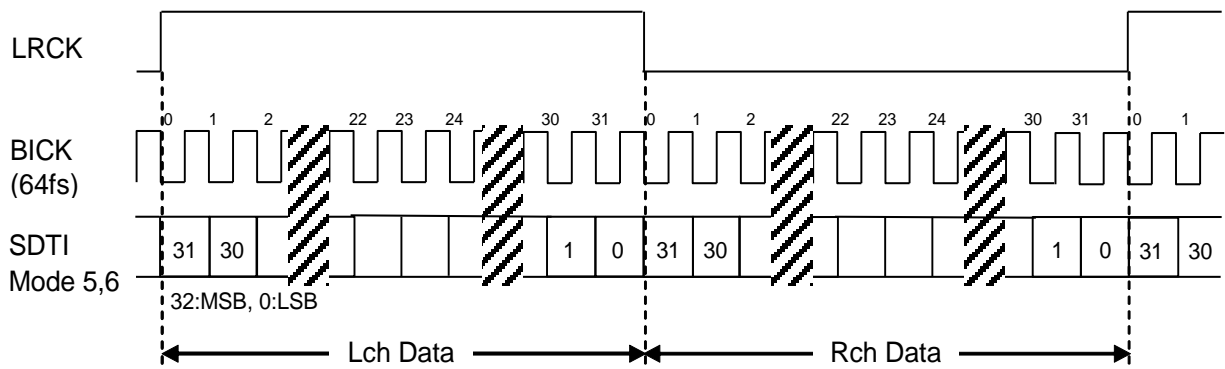

Figure 15. Mode 5/6 Timing

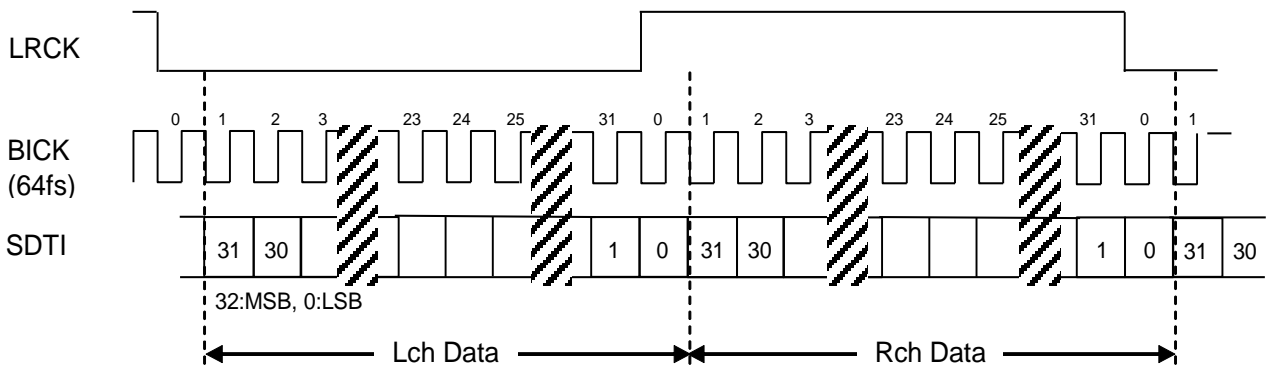

Figure 16. Mode 7 Timing

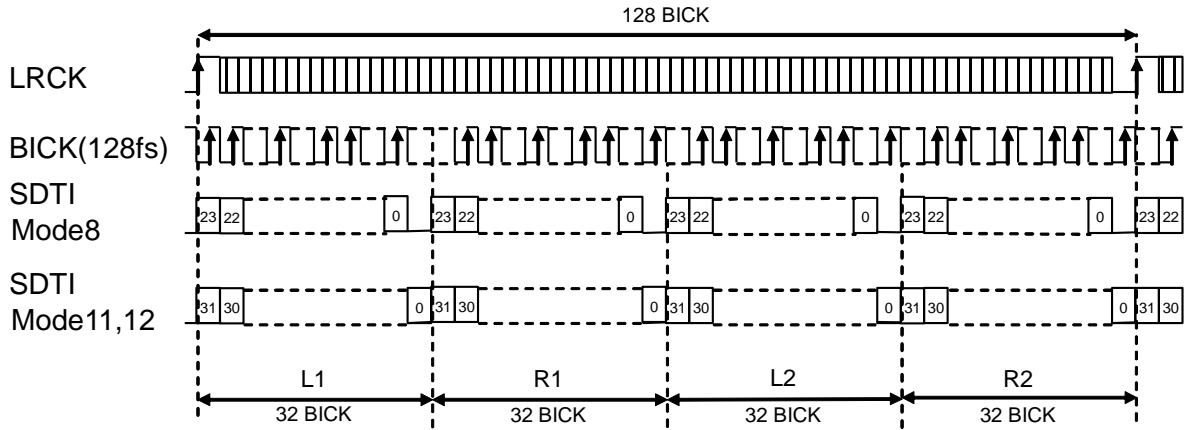

Figure 17. Mode 8/11/12 Timing

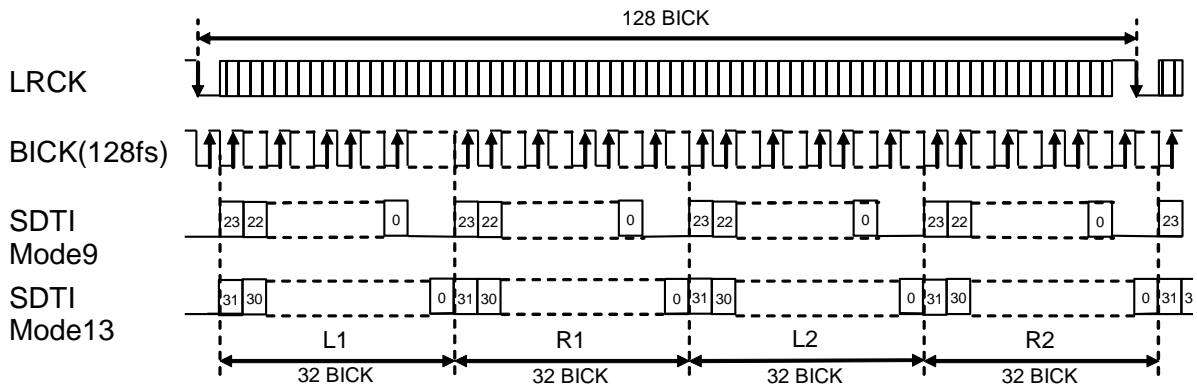

Figure 18. Mode 9/13 Timing

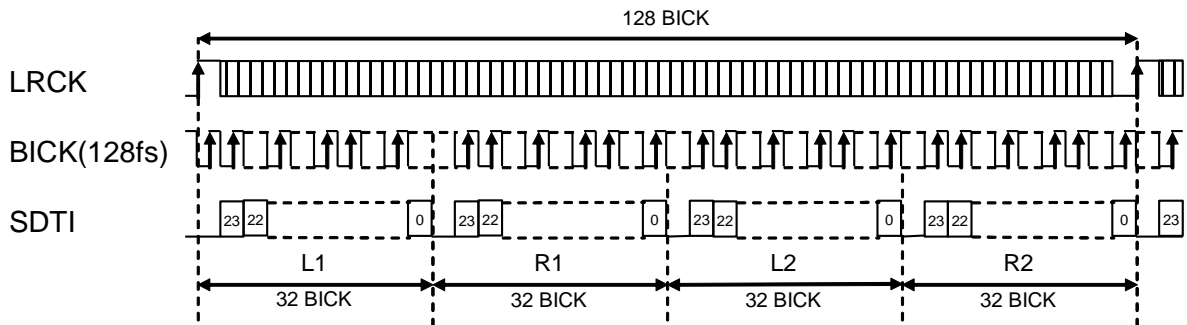

Figure 19. Mode 10 Timing

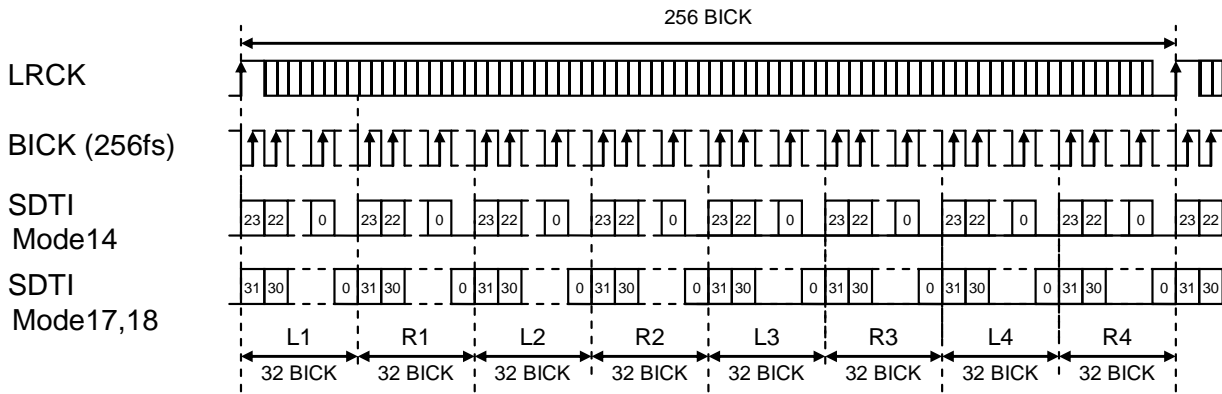

Figure 20. Mode 14/17/18 Timing

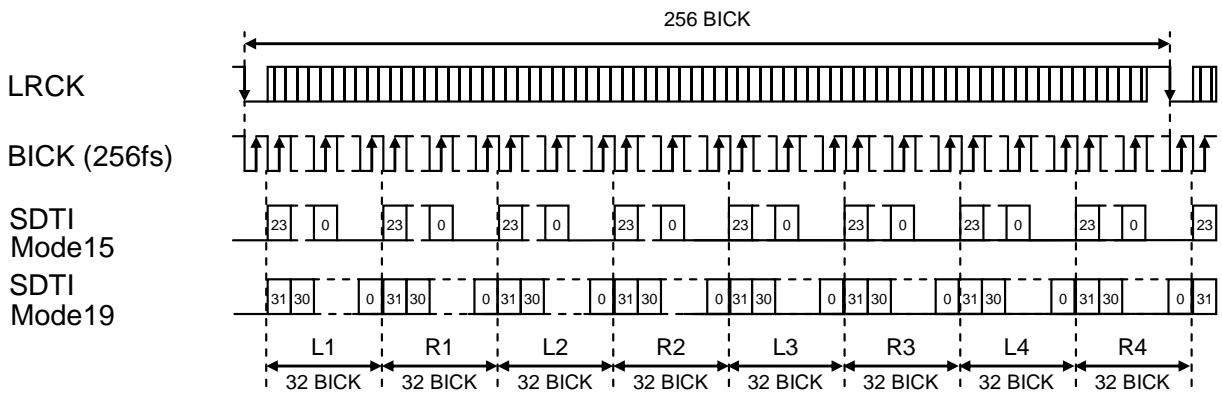

Figure 21. Mode 15/19 Timing

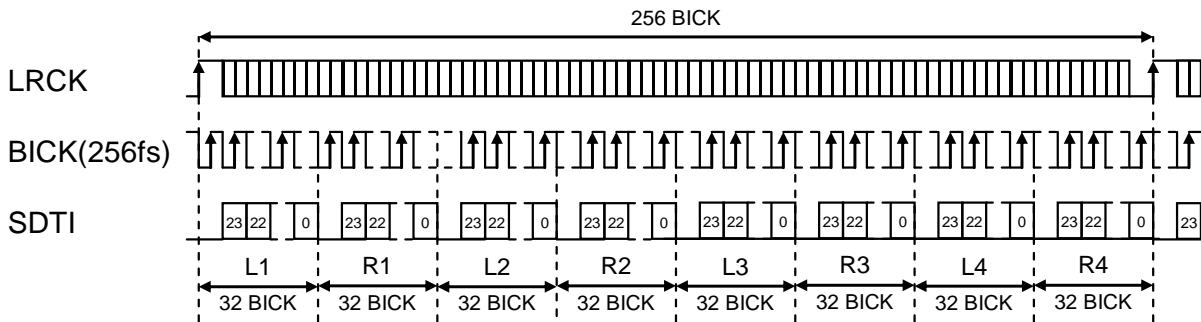

Figure 22. Mode 16 Timing

[2] Data Select

SDS1-0 bits control the playback channel of each DAC.

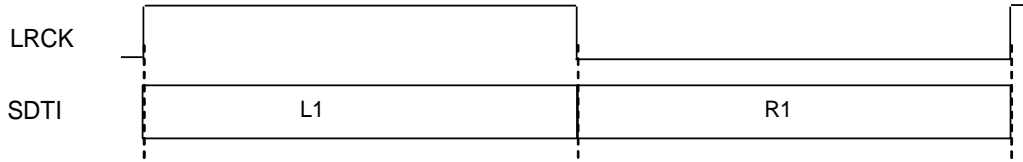

Figure 23. Data Slot in Normal Mode

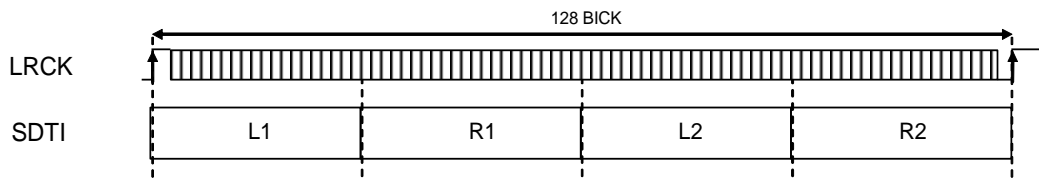

Figure 24. Data Slot in TDM128 Mode

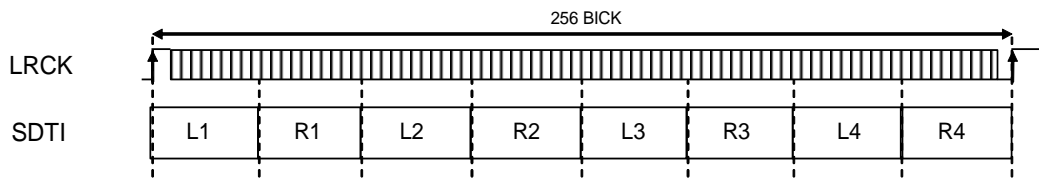

Figure 25. Data Slot in TDM256 Mode

	SDS1	SDS0	DAC1	
			Lch	Rch
Normal	x	x	L1	R1
TDM128	x	0	L1	R1
	x	1	L2	R2
TDM256	0	0	L1	R1
	0	1	L2	R2
	1	0	L3	R3
	1	1	L4	R4

(x: don't care)

Table 8. Data Select

■ Digital Volume Function

The AK4432 has a channel-independent digital attenuator (256 levels, 0.5dB steps). Attenuation level of each channel of the DAC can be set by ATT7-0 bits (register 04-05H), respectively (Table 9).

DAC Lch ATTL7-0bits	DAC Rch ATTR7-0bits	Attenuation Level
00h	00h	+12.0dB
01h	01h	+11.5dB
02h	02h	+11.0dB
:	:	:
17h	17h	+0.5dB
18h	18h	0.0dB
19h	19h	-0.5dB
:	:	:
FDh	FDh	-114.5dB
FEh	FEh	-115.0dB
FFh	FFh	MUTE ($-\infty$)

(default)

Table 9. Attenuation level of Digital Attenuator

Transition time between set values of ATT7-0 bits can be selected by the ATS bit (Table 10). When changing output levels, transitions are executed via soft changes (0.125dB steps by every 1/4 ATT speed); thus not switching noise occurs during these transitions.

Mode	ATS	ATT speed(Transition Time)	
		1 step(0.5dB)	Soft Transition(0.125dB)
0	0	4/fs	1/fs
1	1	16/fs	4/fs

(default)

Table 10. Digital Volume Transition Time

In Mode0, it takes $255\text{step} \cdot 4/\text{fs} + 1/\text{fs}(\text{mute}) = 1020/\text{fs}$ (21.3ms @fs=48kHz) from FFH to 00H and in Mode1, it takes $255\text{step} \cdot 16/\text{fs} + 4/\text{fs}(\text{mute}) = 4084/\text{fs}$ (85.1ms @fs=48kHz).

Mode	ATS	00h \leftrightarrow FFh Transition Time			
		Transition Time(fs)	fs=48kHz	fs=44.1kHz	fs=8kHz
0	0	1021/fs	21.3ms	23.2ms	127.6ms
1	1	4084/fs	85.1ms	92.6ms	510.5ms

(default)

Table 11. Digital Volume Transition Time 00h \leftrightarrow FFh

Just after power up the DAC, the digital volume level is at MUTE. Then, the volume changes to the value set by registers in soft transition after releasing the power-down state.

■ Soft Mute Operation

The soft mute operation is performed at digital domain. When the SMUTE pin goes to “H” or set SMUTE bit to “1”, the output signal is attenuated by $-\infty$ during $ATT_DATA \times ATT$ transition time from the current ATT level. When the SMUTE pin is returned to “L” or the SMUTE bit is returned to “0”, the mute is cancelled and the output attenuation gradually changes to the ATT level during $ATT_DATA \times ATT$ transition time. If the soft mute is cancelled before attenuating $-\infty$, the attenuation is discontinued and returned to ATT level by the same cycle. The soft mute is effective for changing the signal source without stopping the signal transmission.

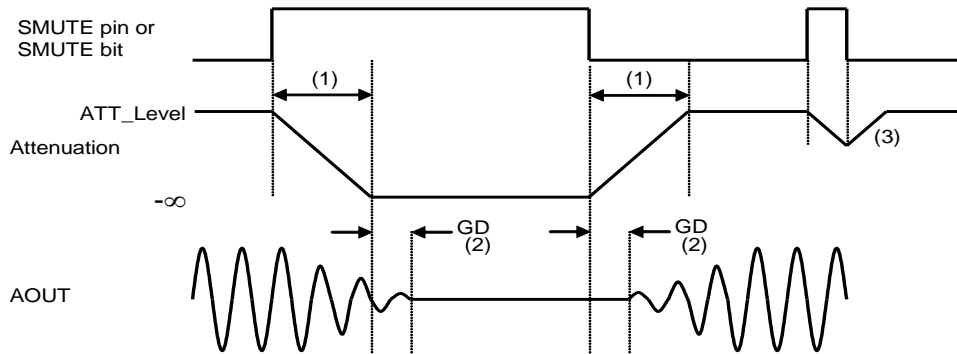

Note:

- (1) $ATT_DATA \times ATT$ transition time. For example, this time is 1020LRCK cycles (1020/fs) at $ATT_DATA=255$ in Normal Speed Mode.
- (2) The analog output corresponding to the digital input has group delay (GD).
- (3) If the soft mute is cancelled before attenuating $-\infty$ after starting the operation, the attenuation is discontinued and returned to ATT level by the same cycle.

Figure 26. Soft Mute Function and Zero Detection

■ Error Detection

Three types of error can be detected by the AK4432 (Table 12). The internal LDO will be powered down and register access will be disabled when an error is detected. Once an error is detected, the AK4432 will not return to normal operation automatically even if all error conditions are removed. Reset the AK4432 once by bringing the PDN pin = "L" and start up again. In I²C mode, errors can be detected by monitoring Acknowledge. If an error occurs, the AK4432 stops sending Acknowledge.

No	Error	Error Condition
1	Internal Reference Voltage Error	Internal reference voltage is not powered up.
2	LDO Over Voltage Detection	LDO voltage > 1.6V (Typ)
3	LDO Over Current Detection	LDO current < 100mA (Typ)

Table 12. ERROR Detection

■ System Reset

The AK4432 should be reset once by bringing the PDN pin = "L" upon power-up. Power-down state of the reference voltage such as LDO and VCOM will be released by the PDN pin = "H", and then after 1ms register writing becomes available. The internal DAC will be powered up after MCLK and LRCK are input. The AK4432 is in power-down state until MCLK and LRCK are input.

■ Power Down Function

The AK4432 is placed in power-down mode by bringing the PDN pin “L” and the analog outputs become floating (Hi-Z) state. Power-up and power-down timings are shown in [Figure 27](#).

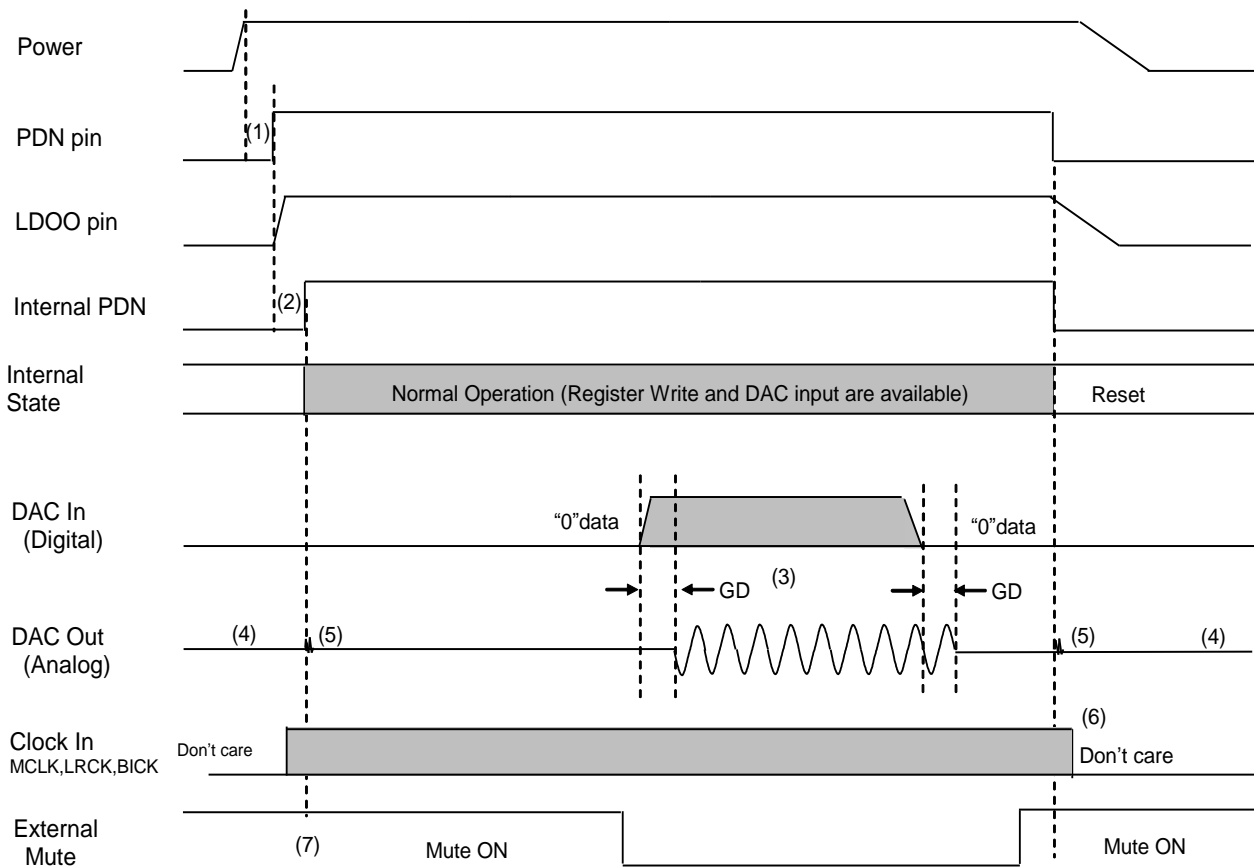

Note:

- (1) After AVDD and LVDD are powered-up, the PDN pin should be “L” for 800ns.
- (2) After PDN pin = “H”, the LDO circuit (internal digital block driving power supply) and REF generating circuit (analog reference voltage source) are powered up, and control registers are initialized. Control register settings should be made after 1ms from the PDN pin = “H”.
- (3) The analog output corresponding to digital input has group delay (GD).
- (4) Analog outputs are floating (Hi-Z) in power down mode.
- (5) Click noise occurs at an edge of PDN signal. This noise is output even if “0” data is input.
- (6) MCLK, BICK and LRCK clocks can be stopped in power-down mode (PDN pin= “L”).
- (7) Mute the analog output externally if click noise (5) adversely affect system performance. The timing example is shown in this figure.

Figure 27. Pin Power Down/Up Sequence Example

■ Power Off and Reset Functions

PMDA	DAC	Register	Digital	Analog Output
0	OFF	Keep	OFF	Hi-Z
1	ON	Keep	ON	normal

(default)

Table 13. Power OFF and Reset Function

(1) Power OFF Function (PMDA bit)

All DACs will be powered down immediately by setting PMDA bit to “0”. In this time, all internal circuits except register are powered down and the analog output goes to floating state (Hi-z). Figure 28 shows a timing example of power-on and power-down.

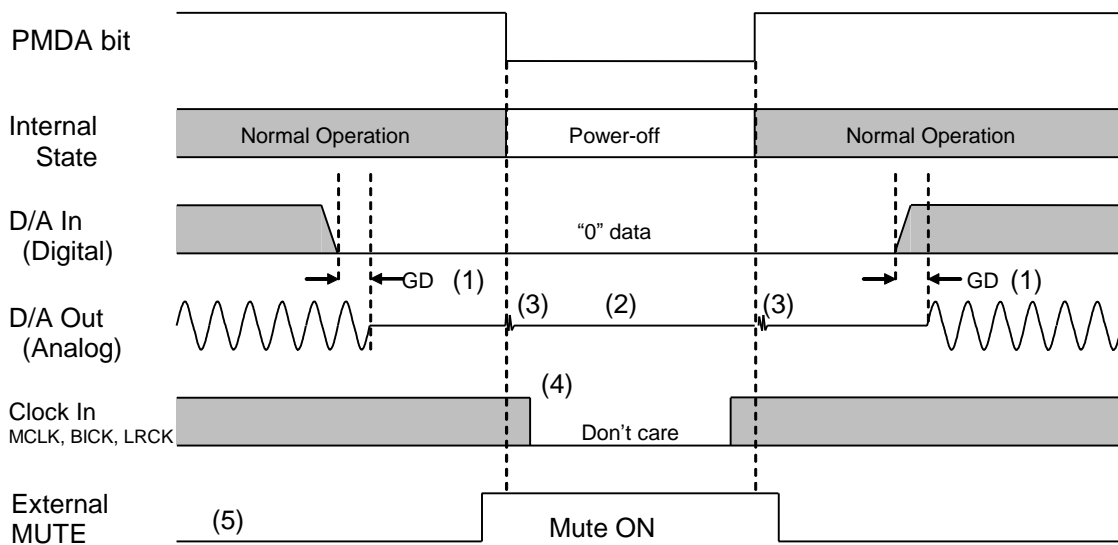

Note:

- (1) The analog output corresponding to digital input has group delay (GD).
- (2) Analog outputs are floating (Hi-Z) in power down mode.
- (3) Click noise occurs at the edges (“↑↓”) of the internal timing of PMDA bit. This noise is output even if “0” data is input.
- (4) Each clock input (MCLK, BICK, LRCK) can be stopped in power down mode (PMDA bit = “0”).
- (5) Mute the analog output externally if the click noise (3) adversely affects system performance.

Figure 28. Power-off/on Sequence Example 1

■ Clock Synchronization

The AK4432 has a reset function of internal counter that keeps the phase difference of the DAC outputs between the AK7738 less than 13/256fs. Clock synchronization function is enabled by SYNCE bit = “1” (default = “1”). SYNCE bit setting must be changed when data is all “0” (no data input). When SYNCE bit = “1” (default) MSB justified and 32-bit I²S compatible formats are available but LSB justified format is not available.

(1) Synchronization with AK7738

In the use cases shown below (Figure 29), the phase difference of DAC output between the AK7738 and the AK4432 can be kept less than 13/256fs by clock synchronization function.

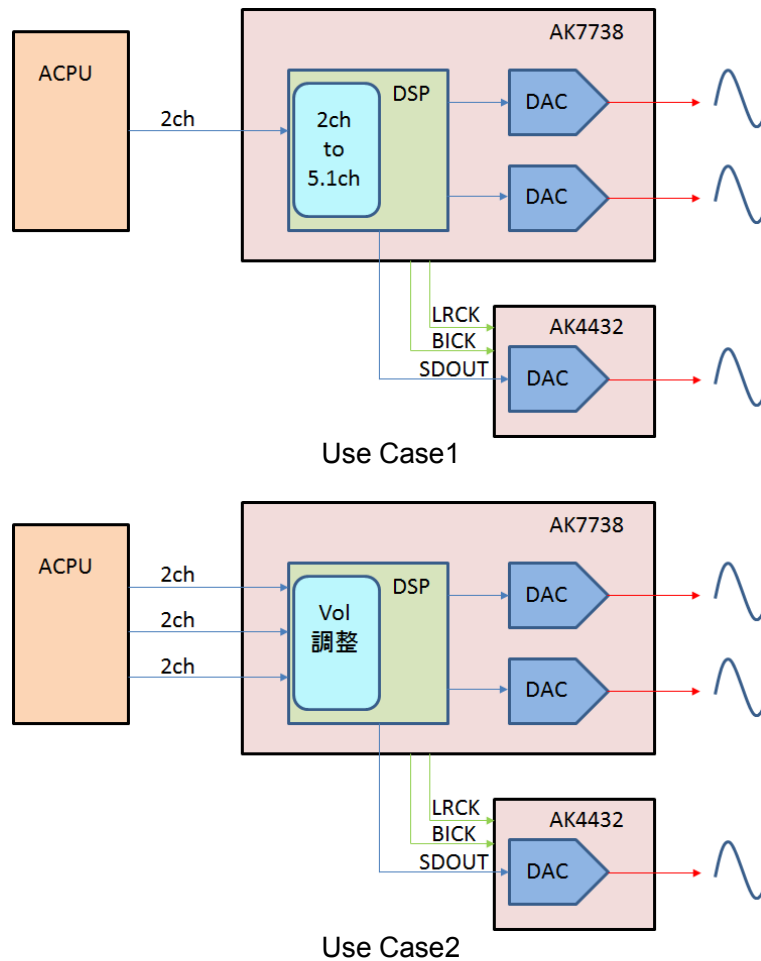

Figure 29. Available Use Cases for Synchronization with the AK7738

Note: When synchronizing with the AK7738, both the AK7738 and the AK4432 should be set as BICK =64fs, 32-bit MSB justified (DIF2-0 bits = “110”).

	LRCK[kHz]	BICK[fs]	MCLK[fs]	MCLK[MHz]	Phase Diff. [1/MCLK]	Phase Diff. [μs]	Phase Diff. [deg] *1
Normal	48	64	256	12.288	7 ~ 13	0.57 ~ 1.06	4.1 ~ 7.6
Double	96	64	256	24.576	9 ~ 12	0.37 ~ 0.49	2.6 ~ 3.5
Quad	192	64	128	24.576	7 ~ 10	0.29 ~ 0.41	2.1 ~ 2.9

Table 14. Phase Difference Relationship between the AK7738 and the AK4432

Note 16. Phase difference to a 20 kHz signal.

■ Parallel Mode

The AK4432 will be in parallel control mode (pin control mode) by bringing the PS pin= "H". In parallel mode, functions that need to set by registers are not available except three followings that can be used by pin settings.

Functions that cannot be controlled by pin settings are operated in their default register settings.

■ Audio Interface

The DIF pin controls audio interface mode (Table 15). Available modes are 32-bit MSB justified (DIF pin = "L") and 32-bit I2C compatible (DIF pin = "H").

DIF pin	Mode
L	Mode6 (Table 7)
H	Mode7 (Table 7)

Table 15. Audio Interface Forma (Parallel Mode)

■ Soft Mute

Soft mute function can be used by controlling SUMTE signal by the SMUTE pin. (Figure 26)

■ System Clock

Auto setting mode becomes available by setting the ACKS pin to "H". The AK4432 is in Manual setting mode when the ACKS pin is "L". In this case, the sampling speed is fixed to Normal speed mode (Table 16). Input MCKI frequency shown in Table 16.

ACKS pin	MCKI	Sampling Speed Mode
L	768fs, 512fs, 384fs, 256fs	Normal Speed Mode
H	512fs, 768fs	Normal Speed Mode
H	256fs, 384fs	Double Speed Mode
H	128fs, 192fs	Quad Speed Mode

Table 16. System Clock (Parallel Mode)

■ Serial Control Interface

The AK4432 corresponds to both 3-wire serial and I²C bus interfaces. After releasing power-down mode, the AK4432 is in I²C interface mode. 3-wire serial mode will be enabled by writing a dummy command four times continuously following power-up when the CSN pin = "H". (Figure 30)

Input "0cDE → 0xADDA → 0x7A" to the CDTI pin during the CSN pin = "L" is defined as a dummy command. The data format is MSB first. (Figure 30)

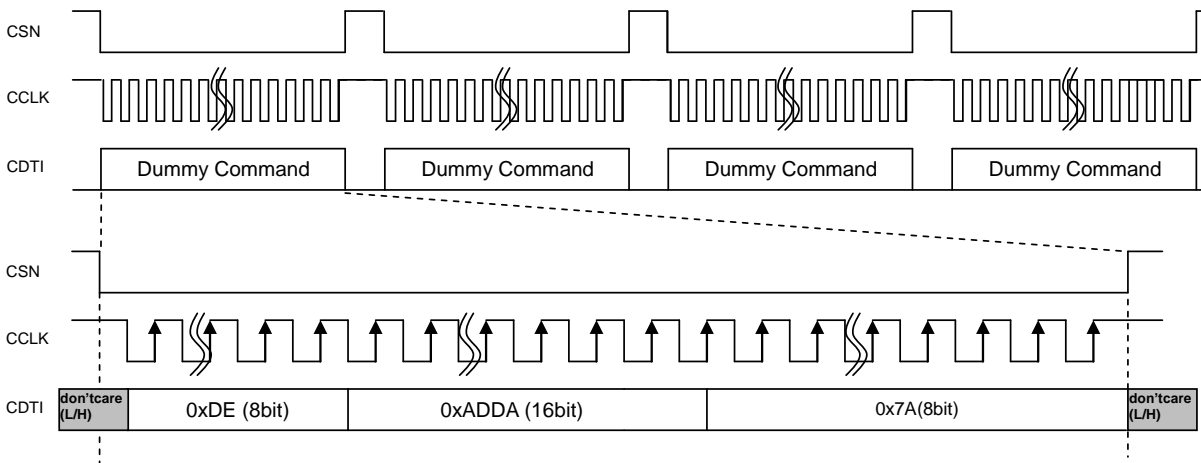

Figure 30. Dummy Comand Format

(1) 3-wire Serial Control Mode (I2C pin = "L")

The internal registers may be written through the 3-wire μ P interface pins (CSN, CCLK and CDTI). The data on this interface consists of a Command code (8bits, the most significant bit is R/W flag and fixed to "1" (write only) and other 7bits are fixed to "1000000"), Register address (MSB first, 16bits) and Control data (MSB first, 8bits) (Figure 31). Address and data are clocked in on the rising edge of CCLK and data is clocked out on the falling edge. For write operations, data is latched on the 8th rising edge of CCLK. The clock speed of CCLK is 7MHz (max).

The AK4432 can perform more than one byte write operation per sequence (Figure 35). The master can transmit more than one byte instead of terminating the write cycle after the first data byte is transferred. After receiving each data packet the internal 16-bit address counter is incremented by one, and the next data is automatically taken into the next address. If the address exceeds 05H prior to generating a stop condition, the address counter will "roll over" to 00H and the previous data will be overwritten.

Internal registers are initialized by setting the PDN pin = "L".

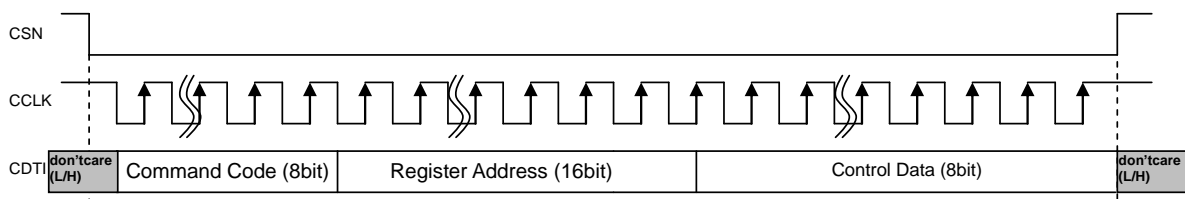
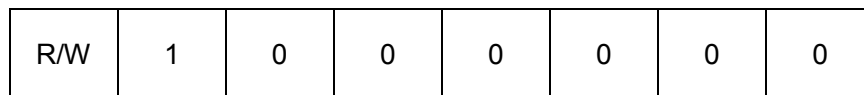

Figure 31. Control I/F Timing



R/W: READ/WRITE (Fixed to "1", Write only)

Figure 32. Command Code

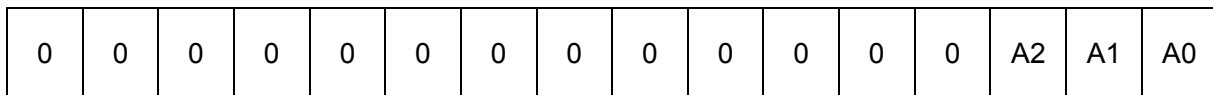

Figure 33. Register Address

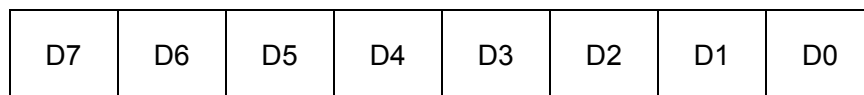

Figure 34. Control Data

- * The AK4432 does not support data read in 3-wire serial mode.
- * Control register write is not possible when the PDN pin = "L".
- * Data will not be written if there are 17times or more CCLK rising edges, or 15times or less CCLK rising edges while the CSN pin is "L".

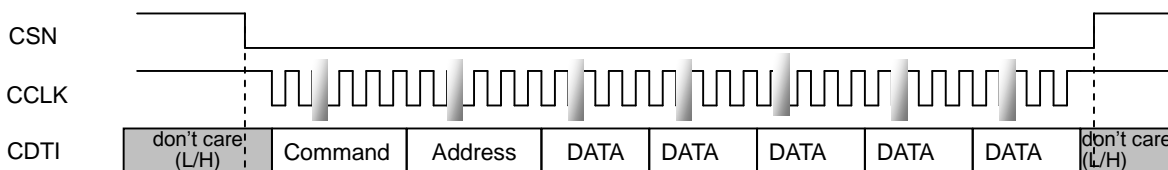

Figure 35. Continuous Write of Control Data

(2) I²C-bus Control Mode

The I²C-bus in the AK4432 can run in fast-mode (max: 400kHz) and fast-mode plus (max: 1MHz) (Table 17). I²C-bus mode should be fixed to either mode during operation. The PDN pin must be “L” when changing the I²C-bus mode.

SMUTE/CSN/I2CFIL pin	Bus Mode
L	Fast Mode
H	Fast Mode Plus

Table 17. I²C-Bus Mode Setting

(1) WRITE Operation

Figure 36 shows the data transfer sequence of the I²C-bus mode. All commands are preceded by a START condition. A High to Low transition on the SDA line while SCL is HIGH indicates a START condition (Figure 44). After a START condition, a slave address is sent. This address is 7 bits long followed by the eighth bit that is a data direction bit (R/W). The most significant seven bits of the slave address are fixed as “0011001” (Figure 37). If the slave address matches that of the AK4432, the AK4432 generates an acknowledge and the operation is executed. The master must generate the acknowledge-related clock pulse and release the SDA line (HIGH) during the acknowledge clock pulse (Figure 45). R/W bit = “1” indicates that the read operation is to be executed. “0” indicates that the write operation is to be executed.

The second byte is an 8-bit command code. The format is MSB first, and it is fixed to “11000000” (Figure 38).

The third byte and fourth byte consist of the control register address of the AK4432. The format is MSB first, the third byte is fixed to zeros and the most significant 5bits of the fourth byte are fixed to zeros (Figure 39, Figure 40). The data after the fifth byte contains control data. The format is MSB first, 8bits (Figure 41). The AK4432 generates an acknowledge after each byte is received. Data transfer is always terminated by a STOP condition generated by the master. A LOW to HIGH transition on the SDA line while SCL is HIGH defines STOP condition (Figure 44).

The AK4432 can perform more than one byte write operation per sequence. The master can transmit more than one byte instead of terminating the write cycle after the first data byte is transferred. After receiving each data packet the internal 16-bit address counter is incremented by one, and the next data is automatically taken into the next address. If the address exceeds “05H” prior to generating a stop condition, the address counter will “roll over” to “00H” and the previous data will be overwritten.

The data on the SDA line must remain stable during the HIGH period of the clock. The HIGH or LOW state of the data line can only be changed when the clock signal on the SCL line is LOW (Figure 46) except for the START and STOP conditions.

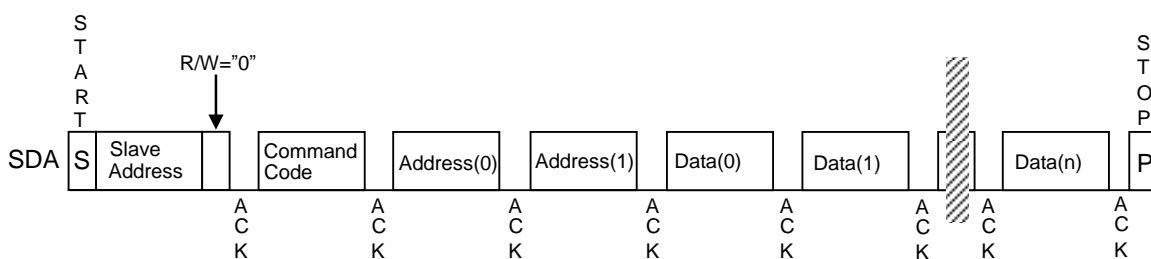
Figure 36. Data Transfer Sequence in I²C-bus Mode

0	0	1	1	0	0	1	R/W
---	---	---	---	---	---	---	-----

R/W: READ/WRITE ("0": Write, "1": Read)

Figure 37. The First Byte

1	1	0	0	0	0	0	0
---	---	---	---	---	---	---	---

Figure 38. The Second Byte

0	0	0	0	0	0	0	0
---	---	---	---	---	---	---	---

Figure 39. The Third Byte

0	0	0	0	0	A2	A1	A0
---	---	---	---	---	----	----	----

Figure 40. The Fourth Byte

D7	D6	D5	D4	D3	D2	D1	D0
----	----	----	----	----	----	----	----

Figure 41. Byte Structure of The Fifth and Succeeding Bytes

(2) READ Operation

In the AK4432, when a “write- slave-address assignment” (R/W bit = “0”) is received at the first byte(Figure 37), the command code “01000000”(Figure 44) at the second byte and the address at the third and fourth bytes are received (Figure 39, Figure 40). When the fourth byte is received and an acknowledgement is transmitted, the read command waits for the next restart condition. After receiving the restart condition, if a “read slave-address assignment” is received at the first byte, data is transferred at the second and succeeding bytes. When the master does not generate an acknowledge but generates a stop condition instead, the AK4432 ceases transmission.

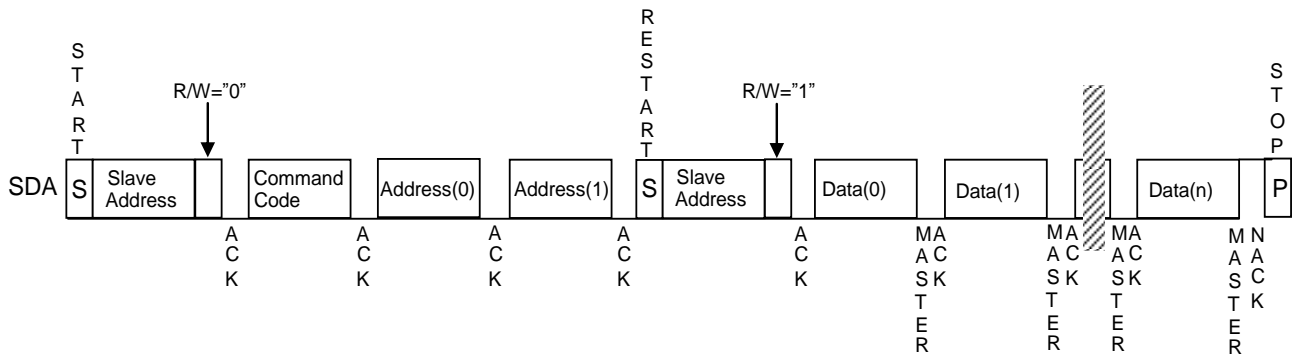

Figure 42. Random Address Read

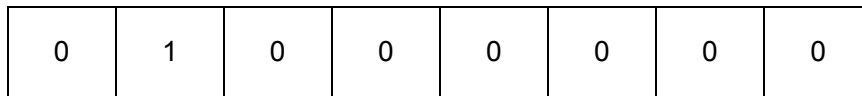

Figure 43. The Second Byte (READ)

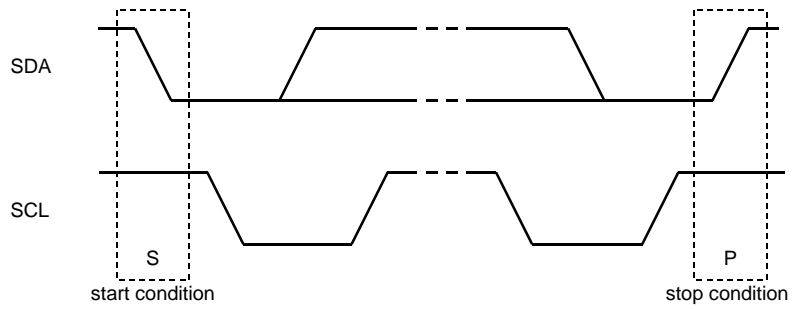

Figure 44. START and STOP Conditions

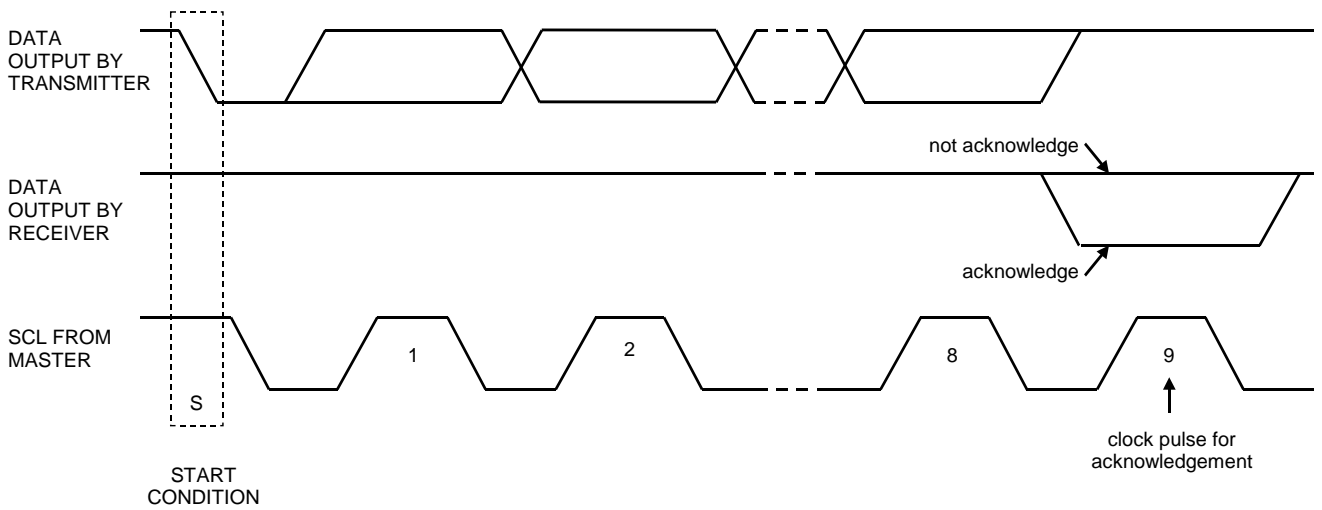

Figure 45. Acknowledge on the I²C-Bus

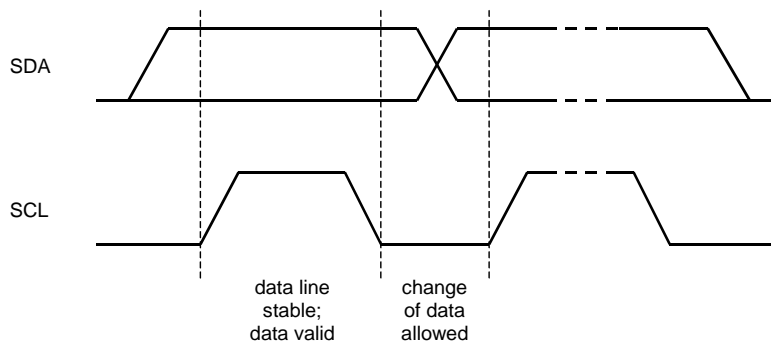

Figure 46. Bit Transfer on the I²C-Bus

■ Register Map

Addr	Register Name	D7	D6	D5	D4	D3	D2	D1	D0
00H	Power Management	0	0	0	0	0	0	PMDA	0
01H	Control 1	0	0	0	0	0	DFS1	DFS0	ACKS
02H	Data interface	0	SDS1	SDS0	TDM1	TDM0	DIF2	DIF1	DIF0
03H	Control 2	0	0	0	DASL	DASD	ATS	SMUTE	SYNCE
04H	AOUTL Volume Control	ATTL7	ATTL6	ATTL5	ATTL4	ATTL3	ATTL2	ATTL1	ATTLO
05H	AOUTR Volume Control	ATTR7	ATTR6	ATTR5	ATTR4	ATTR3	ATTR2	ATTR1	ATTR0

Note 17. Data must not be written into addresses from 06H to FFH.

Note 18. The bit defined as 0 must contain a "0" value.

Note 19. When the PDN pin goes to "L", the registers are initialized to their default values.

■ Register Definitions

Addr	Register Name	D7	D6	D5	D4	D3	D2	D1	D0
00H	Power Management	0	0	0	0	0	0	PMDA	0
	R/W	R/W	R/W	R/W	R/W	R/W	R/W	R/W	R/W
	Default	0	0	0	0	0	0	1	0

RMDA: DAC Power Management
 0: Power Down
 1: Normal Operation

Addr	Register Name	D7	D6	D5	D4	D3	D2	D1	D0
01H	Control 1	0	0	0	0	0	DFS1	DFS0	ACKS
	R/W	R/W	R/W	R/W	R/W	R/W	R/W	R/W	R/W
	Default	0	0	0	0	0	0	0	0

ACKS: Master Clock Frequency Auto Setting Mode Enable
 0: Disable, Manual Setting Mode
 1: Enable, Auto Setting Mode
 When ACKS bit = "1", the MCLK frequency is detected automatically. In this case, the setting of DFS bits is ignored. When this bit is "0", DFS1-0 bits set the sampling speed mode and MCLK frequency for each mode is detected automatically.

DFS1-0: Sampling Speed Mode ([Table 1](#))
 The setting of DFS bits is ignored at ACKS bit = "1".

Addr	Register Name	D7	D6	D5	D4	D3	D2	D1	D0
02H	Data interface	0	SDS1	SDS0	TDM1	TDM0	DIF2	DIF1	DIF0
	R/W	R/W	R/W	R/W	R/W	R/W	R/W	R/W	R/W
	Default	0	0	0	0	0	1	1	0

DIF2-0: Audio Interface Mode Select ([Table 7](#))
 Default: "110" (32-bit MSB justified)

TDM1-0: TDM Format Select
 Default: "00" (Stereo Mode)

Mode	TDM1	TDM0	Sampling Speed Mode
0	0	0	Stereo mode (Normal, Double, Quad Speed Mode)
1	0	1	TDM128 mode (Normal, Double, Quad Speed Mode)
2	1	0	TDM256 mode (Double, Quad Speed Mode)
3	1	1	TDM256 mode (Double, Quad Speed Mode)

SDS1-0: DAC Data Select
 Default: "00" (Stereo Mode)
 0: Normal Operation
 1: Output Other Slot Data ([Table 8](#))

Addr	Register Name	D7	D6	D5	D4	D3	D2	D1	D0
03H	Control 2	0	0	0	DASL	DASD	ATS	SMUTE	SYNCE
	R/W	R/W	R/W	R/W	R/W	R/W	R/W	R/W	R/W
	Default	0	0	0	0	0	0	0	1

SYNCE: SYNC Mode Enable

0: OFF

1: ON (default)

SMUTE: Soft Mute Enable

0: Normal Operation

1: All DAC outputs are soft muted

ATS: Transition Time Setting of Digital Attenuator (Table 10)

Default: "00"

DASD: Digital Filter Setting for DAC Block

0: Sharp roll off filter or Slow roll off filter (default)

1: Short delay Sharp roll off filter or Short delay Slow roll off filter

DASL: Slow Roll-off Filter Enable for DAC Block

0: Sharp Roll-off Filter (default)

1: Slow Roll-off Filter

DASD bit	DASL bit	Mode
0	0	Sharp roll-off filter
0	1	Slow roll-off filter
1	0	Short delay Sharp roll-off filter
1	1	Short delay Slow roll-off filter

(default)

Table 18 Digital Filter setting for DAC Block

Addr	Register Name	D7	D6	D5	D4	D3	D2	D1	D0
04H	AOUTL Volume Control	ATTL7	ATTL6	ATTL5	ATTL4	ATTL3	ATTL2	ATTL1	ATTL0
05H	AOUTR Volume Control	ATTR7	ATTR6	ATTR5	ATTR4	ATTR3	ATTR2	ATTR1	ATTR0
	R/W	R/W	R/W	R/W	R/W	R/W	R/W	R/W	R/W
	Default	0	0	0	1	1	0	0	0

ATTL7-0: DAC Lch Attenuation Level

Default:18(0dB)

ATTR7-0: DAC Rch Attenuation Level

Default:18(0dB)

13. Recommended External Circuits

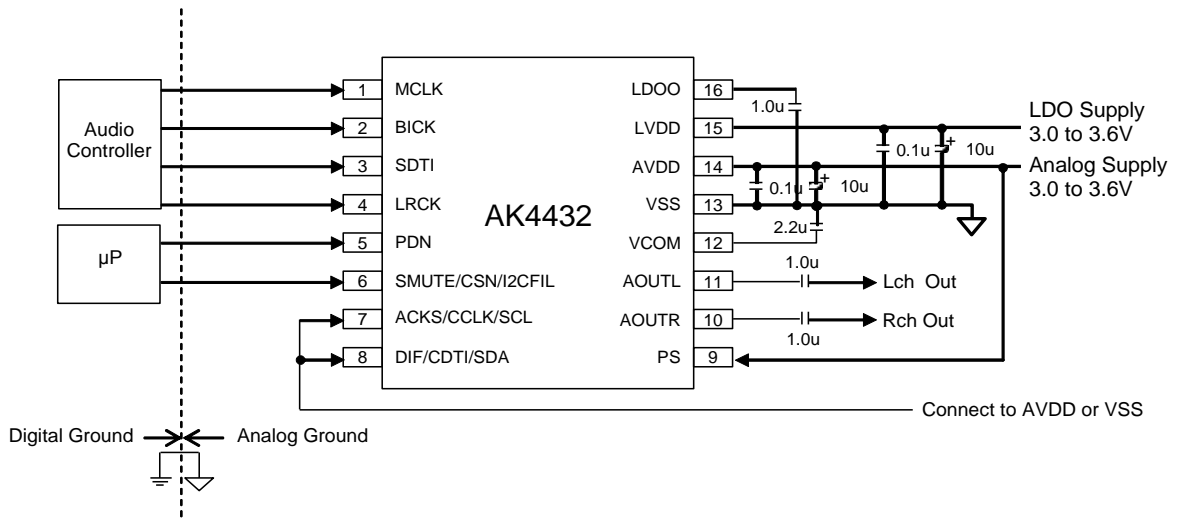

Figure 47. System Connection Diagram (P/S pin = "H")

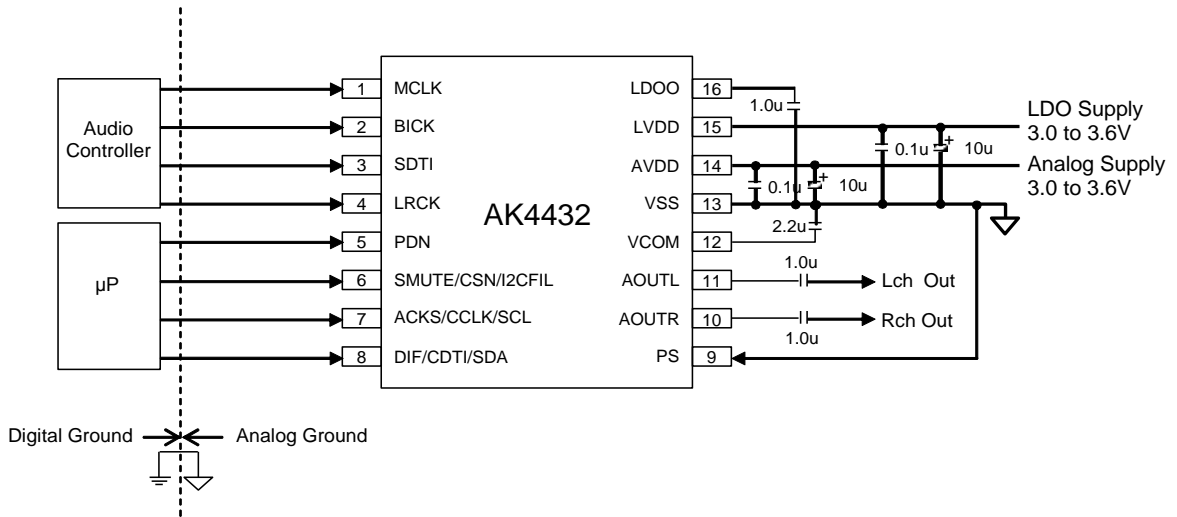

Figure 48. System Connection Diagram (P/S pin = "L")

1. Grounding and Power Supply Decoupling

The AK4432 requires careful attention to power supply and grounding arrangements. **VSS must be connected to the same analog ground plane.** Decoupling capacitors should be as near to the AK4432 as possible.

2. Voltage Reference

VCOM is a signal ground of this chip and output the voltage $AVDD \times 1/2$. A $2.2\mu\text{F}$ ($\pm 50\%$ includes temperature characteristics) ceramic capacitor attached between the VCOM pin and VSS eliminates the effects of high frequency noise. This capacitor should be as close to the pin as possible. No load current may be drawn from the VCOM pin. All signals, especially clocks, should be kept away from the VCOM pin in order to avoid unwanted coupling into the AK4432.

The LDOO pin is a power supply for internal digital circuit and outputs 1.2V. A $1\mu\text{F}$ ($\pm 50\%$ includes temperature characteristics) ceramic capacitor attached between the LDOO pin and VSS eliminates the effects of high frequency noise. This capacitor should be connected as close as possible to the pin. No load current may be drawn from the LDOO pin.

3. Analog Output

The output signal range is nominally $0.86 \times AVDD V_{pp}$ (typ.) centered around the VCOM voltage. The DAC input data format is 2's complement. The output voltage is a positive full scale for 7FFFFFFH(@32bit) and a negative full scale for 80000000H(@32bit). The ideal output is VCOM voltage for 00000000H(@32bit). The internal analog filters remove most of the noise generated by the delta-sigma modulator of DAC beyond the audio passband, in single-ended input mode.

DC offsets on analog outputs are eliminated by AC coupling since DAC outputs have DC offsets of a few mV.

14. Package

■ Outline Dimensions

16-pin TSSOP (Unit: mm)

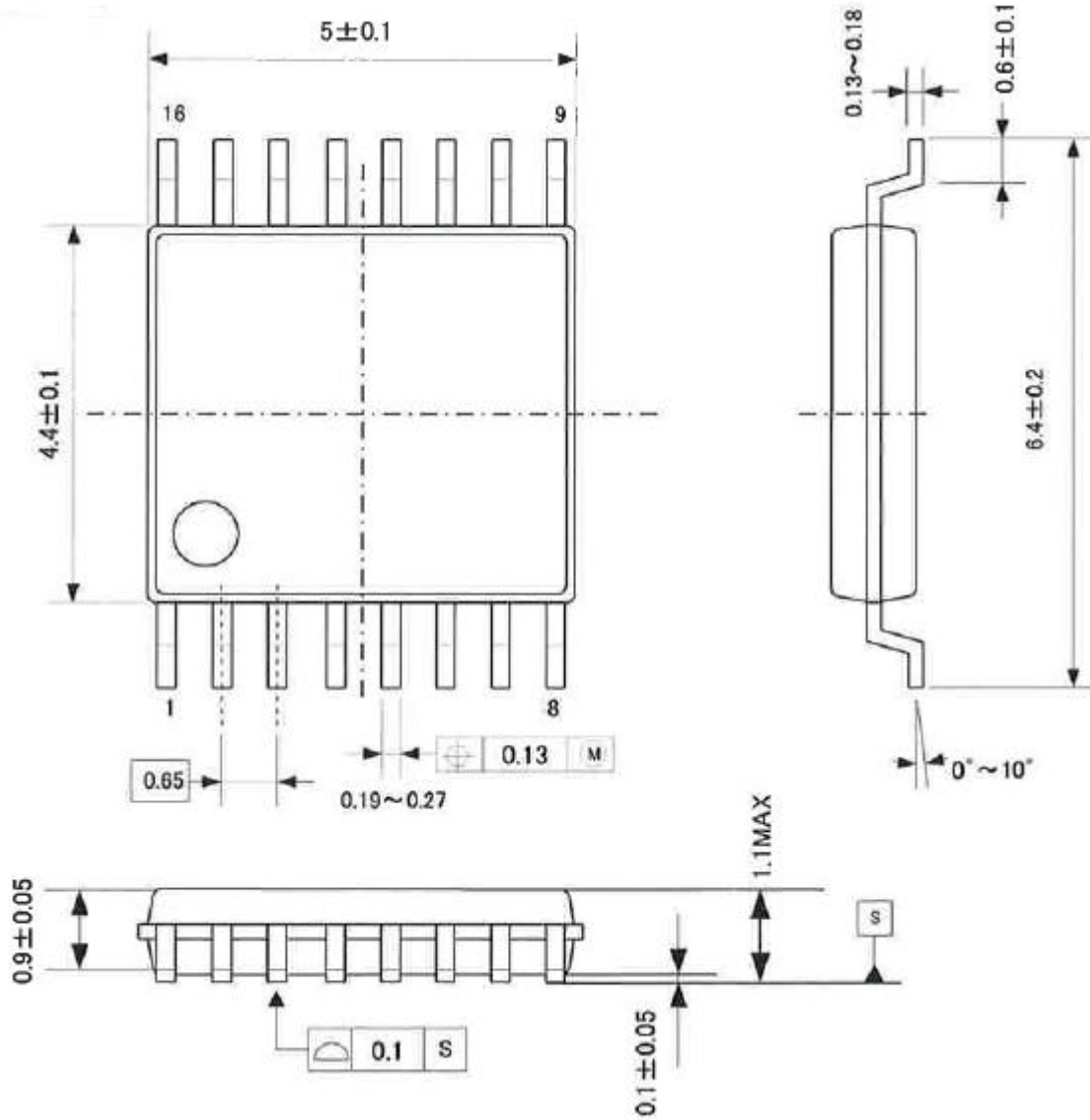

■ Material & Lead Finish

Package molding compound: Epoxy, Halogen (Br and Cl) free
 Lead frame material: Cu
 Lead frame surface treatment: Solder (Pb free) plate

■ **Marking**

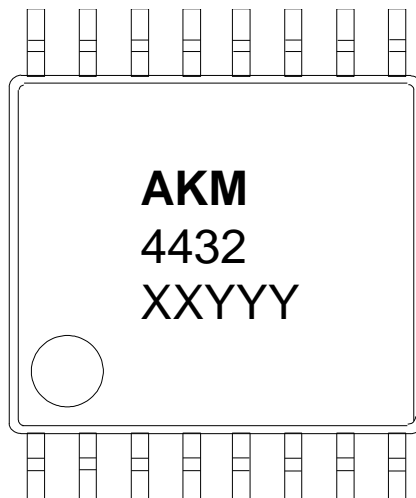

- 1) Pin #1 indication
- 2) Date Code: XXXX (4 digits)
- 3) Marking Code: 4432

15. Revision History

Date (Y/M/D)	Revision	Reason	Page	Contents
15/02/18	00	First Edition		

IMPORTANT NOTICE

0. Asahi Kasei Microdevices Corporation ("AKM") reserves the right to make changes to the information contained in this document without notice. When you consider any use or application of AKM product stipulated in this document ("Product"), please make inquiries the sales office of AKM or authorized distributors as to current status of the Products.
1. All information included in this document are provided only to illustrate the operation and application examples of AKM Products. AKM neither makes warranties or representations with respect to the accuracy or completeness of the information contained in this document nor grants any license to any intellectual property rights or any other rights of AKM or any third party with respect to the information in this document. You are fully responsible for use of such information contained in this document in your product design or applications. AKM ASSUMES NO LIABILITY FOR ANY LOSSES INCURRED BY YOU OR THIRD PARTIES ARISING FROM THE USE OF SUCH INFORMATION IN YOUR PRODUCT DESIGN OR APPLICATIONS.
2. The Product is neither intended nor warranted for use in equipment or systems that require extraordinarily high levels of quality and/or reliability and/or a malfunction or failure of which may cause loss of human life, bodily injury, serious property damage or serious public impact, including but not limited to, equipment used in nuclear facilities, equipment used in the aerospace industry, medical equipment, equipment used for automobiles, trains, ships and other transportation, traffic signaling equipment, equipment used to control combustions or explosions, safety devices, elevators and escalators, devices related to electric power, and equipment used in finance-related fields. Do not use Product for the above use unless specifically agreed by AKM in writing.
3. Though AKM works continually to improve the Product's quality and reliability, you are responsible for complying with safety standards and for providing adequate designs and safeguards for your hardware, software and systems which minimize risk and avoid situations in which a malfunction or failure of the Product could cause loss of human life, bodily injury or damage to property, including data loss or corruption.
4. Do not use or otherwise make available the Product or related technology or any information contained in this document for any military purposes, including without limitation, for the design, development, use, stockpiling or manufacturing of nuclear, chemical, or biological weapons or missile technology products (mass destruction weapons). When exporting the Products or related technology or any information contained in this document, you should comply with the applicable export control laws and regulations and follow the procedures required by such laws and regulations. The Products and related technology may not be used for or incorporated into any products or systems whose manufacture, use, or sale is prohibited under any applicable domestic or foreign laws or regulations.
5. Please contact AKM sales representative for details as to environmental matters such as the RoHS compatibility of the Product. Please use the Product in compliance with all applicable laws and regulations that regulate the inclusion or use of controlled substances, including without limitation, the EU RoHS Directive. AKM assumes no liability for damages or losses occurring as a result of noncompliance with applicable laws and regulations.
6. Resale of the Product with provisions different from the statement and/or technical features set forth in this document shall immediately void any warranty granted by AKM for the Product and shall not create or extend in any manner whatsoever, any liability of AKM.
7. This document may not be reproduced or duplicated, in any form, in whole or in part, without prior written consent of AKM.