

## 阅读申明

- 1.本站收集的数据手册和产品资料都来自互联网，版权归原作者所有。如读者和版权方有任何异议请及时告之，我们将妥善解决。
- 2.本站提供的中文数据手册是英文数据手册的中文翻译，其目的是协助用户阅读，该译文无法自动跟随原稿更新，同时也可能存在翻译上的不当。建议读者以英文原稿为参考以便获得更精准的信息。
- 3.本站提供的产品资料，来自厂商的技术支持或者使用者的心得体会等，其内容可能存在描述上的差异，建议读者做出适当判断。
- 4.如需与我们联系，请发邮件到marketing@iczoom.com，主题请标有“数据手册”字样。

## Read Statement

1. The datasheets and other product information on the site are all from network reference or other public materials, and the copyright belongs to the original author and original published source. If readers and copyright owners have any objections, please contact us and we will deal with it in a timely manner.
2. The Chinese datasheets provided on the website is a Chinese translation of the English datasheets. Its purpose is for reader's learning exchange only and do not involve commercial purposes. The translation cannot be automatically updated with the original manuscript, and there may also be improper translations. Readers are advised to use the English manuscript as a reference for more accurate information.
3. All product information provided on the website refer to solutions from manufacturers' technical support or users the contents may have differences in description, and readers are advised to take the original article as the standard.
4. If you have any questions, please contact us at marketing@iczoom.com and mark the subject with "Datasheets" .

### FEATURES

- Programmable capacitance-to-digital converter (CDC)**
  - Femtofarad (fF) resolution
  - 13 capacitance sensor inputs
  - 9 ms update rate, all 13 sensor inputs
  - No external RC components required
  - Automatic conversion sequencer
- On-chip automatic calibration logic**
  - Automatic compensation for environmental changes
  - Automatic adaptive threshold and sensitivity levels
- Register map is compatible with the AD714x**
- On-chip RAM to store calibration data**
- Serial peripheral interface (SPI) (AD7147A)**
- I<sup>2</sup>C-compatible serial interface (AD7147A-1)**
- Separate V<sub>DRIVE</sub> level for serial interface**
- Interrupt output and general-purpose input/output (GPIO)**
- 25-ball, 2.3 mm × 2.1 mm WLCSP**
- 2.6 V to 3.6 V supply voltage**
- Low operating current**
  - Full power mode: 1 mA
  - Low power mode: 28.96 μA

### APPLICATIONS

- Cell phones
- Personal music and multimedia players
- Smart handheld devices
- Television, A/V, and remote controls
- Gaming consoles
- Digital still cameras

### GENERAL DESCRIPTION

The AD7147A CapTouch™ controller is designed for use with capacitance sensors implementing functions such as buttons, scroll bars, and wheels. The sensors need only one PCB layer, enabling ultrathin applications.

The AD7147A is an integrated CDC with on-chip environmental calibration. The CDC has 13 inputs channeled through a switch matrix to a 16-bit, 250 kHz sigma-delta ( $\Sigma$ - $\Delta$ ) converter. The CDC is capable of sensing changes in the capacitance of the external sensors and uses this information to register a sensor activation. By programming the registers, the user has full control over the CDC setup.

High resolution sensors require minor software to run on the host processor and may require two PCB layers.

#### Rev. B

Information furnished by Analog Devices is believed to be accurate and reliable. However, no responsibility is assumed by Analog Devices for its use, nor for any infringements of patents or other rights of third parties that may result from its use. Specifications subject to change without notice. No license is granted by implication or otherwise under any patent or patent rights of Analog Devices. Trademarks and registered trademarks are the property of their respective owners.

### FUNCTIONAL BLOCK DIAGRAM

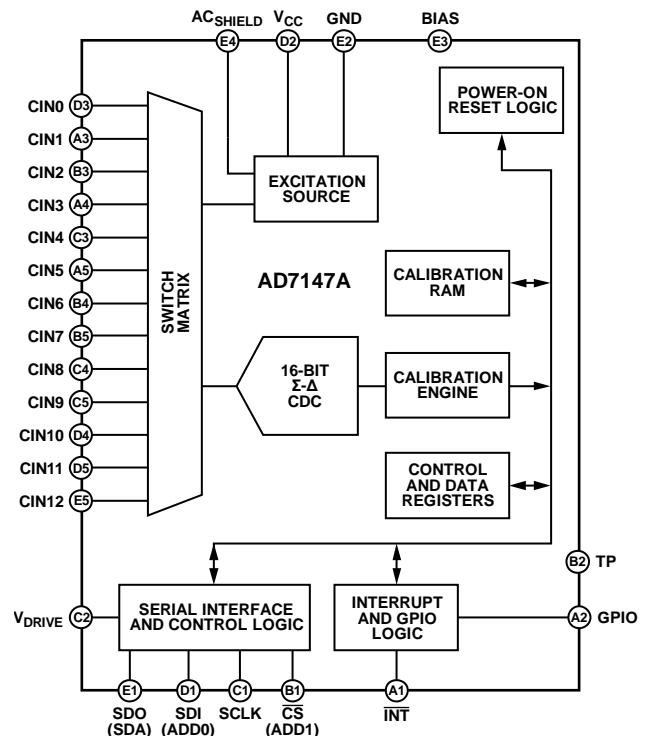

NOTES  
1. PIN NAMES IN PARENTHESES ARE FOR THE AD7147A-1.

Figure 1.

The AD7147A is designed for single electrode capacitance sensors (grounded sensors). There is an active shield output to minimize noise pickup in the sensor.

The AD7147A has on-chip calibration logic to compensate for changes in the ambient environment. The calibration sequence is performed automatically and at continuous intervals as long as the sensors are not touched. This ensures that there are no false or nonregistering touches on the external sensors due to a changing environment.

The AD7147A has an SPI-compatible serial interface, and the AD7147A-1 has an I<sup>2</sup>C-compatible serial interface. Both parts have an interrupt output, as well as a GPIO. There is a V<sub>DRIVE</sub> pin to set the voltage level for the serial interface independent of V<sub>CC</sub>.

The AD7147A is available in a 25-ball, 2.3 mm × 2.1 mm WLCSP and operates from a 2.6 V to 3.6 V supply. The operating current consumption in low power mode is typically 28.96 μA for 13 sensors.

# AD7147A\* PRODUCT PAGE QUICK LINKS

Last Content Update: 02/23/2017

---

## COMPARABLE PARTS

View a parametric search of comparable parts.

## DOCUMENTATION

### Application Notes

- AN-925: Sensors for the AD7147 and AD7148 CapTouch® Controllers
- AN-929: Tuning the AD714x for CapTouch® Applications

### Data Sheet

- AD7147A: CapTouch Programmable Controller for Single-Electrode Capacitance Sensors Data Sheet

## SOFTWARE AND SYSTEMS REQUIREMENTS

- AD714X Input CapTouch® Programmable Controller Linux Driver

## DESIGN RESOURCES

- AD7147A Material Declaration
- PCN-PDN Information
- Quality And Reliability
- Symbols and Footprints

## DISCUSSIONS

View all AD7147A EngineerZone Discussions.

## SAMPLE AND BUY

Visit the product page to see pricing options.

## TECHNICAL SUPPORT

Submit a technical question or find your regional support number.

## DOCUMENT FEEDBACK

Submit feedback for this data sheet.

---

## TABLE OF CONTENTS

Features .....	1	Capacitance Sensor Behavior Without Calibration.....	23
Applications.....	1	Threshold Equations.....	23
General Description .....	1	Capacitance Sensor Behavior with Calibration.....	24
Functional Block Diagram .....	1	Slow FIFO.....	24
Revision History .....	2	SLOW_FILTER_UPDATE_LVL .....	24
Specifications.....	3	Adaptive Threshold and Sensitivity .....	25
Average Current Specifications .....	4	Interrupt Output.....	27
SPI Timing Specifications (AD7147A).....	5	CDC Conversion-Complete Interrupt .....	27
I <sup>2</sup> C Timing Specifications (AD7147A-1) .....	6	Sensor-Touch Interrupt.....	27
Absolute Maximum Ratings.....	7	GPIO $\overline{\text{INT}}$ Output Control .....	29
ESD Caution.....	7	Outputs .....	31
Pin Configurations and Function Descriptions .....	8	AC <sub>SHIELD</sub> Output .....	31
Typical Performance Characteristics .....	9	General-Purpose Input/Output (GPIO) .....	31
Theory of Operation .....	11	Using the GPIO to Turn On/Off an LED.....	31
Capacitance Sensing Theory.....	11	Serial Interfaces.....	32
BIAS Pin.....	12	SPI Interface .....	32
Operating Modes.....	12	I <sup>2</sup> C-Compatible Interface .....	34
Capacitance-to-Digital Converter .....	14	V <sub>DRIVE</sub> Input .....	36
Oversampling the CDC Output .....	14	PCB Design Guidelines .....	37
Capacitance Sensor Offset Control.....	14	Capacitive Sensor Board Mechanical Specifications .....	37
Conversion Sequencer .....	14	WLCSP Package .....	37
CDC Conversion Sequence Time .....	16	Power-Up Sequence .....	38
CDC Conversion Results.....	16	Typical Application Circuits .....	39
Capacitance Sensor Input Configuration.....	17	Register Map .....	40
CINx Input Multiplexer Setup.....	17	Detailed Register Descriptions .....	41
Single-Ended Connections to the CDC .....	17	Bank 1 Registers .....	41
Noncontact Proximity Detection .....	18	Bank 2 Registers .....	51
Recalibration .....	18	Bank 3 Registers .....	56
Proximity Sensitivity .....	18	Outline Dimensions .....	68
FF_SKIP_CNT.....	21	Ordering Guide .....	68
Environmental Calibration .....	23		

## REVISION HISTORY

### 12/09—Rev. A to Rev. B

Changes to Figure 1.....	1
Changes to Figure 5, Figure 6, and Pin Description for B2 .....	8
Changes to Figure 59 and Figure 60.....	39
Changes to Ordering Guide .....	68

### 3/09—Rev. 0 to Rev. A

Changes to Ordering Guide.....	68
--------------------------------	----

### 1/09—Revision 0: Initial Version

## SPECIFICATIONS

$V_{CC} = 2.6\text{ V to }3.6\text{ V}$ ,  $T_A = -40^\circ\text{C to }+85^\circ\text{C}$ , unless otherwise noted.

**Table 1.**

Parameter	Min	Typ	Max	Unit	Test Conditions/Comments
<b>CAPACITANCE-TO-DIGITAL CONVERTER</b>					
Update Rate	8.73	9	9.27	ms	12 conversion stages, decimation = 64
	17.46	18	18.54	ms	12 conversion stages, decimation = 128
	34.9	36	37.1	ms	12 conversion stages, decimation = 256
Resolution		16		Bits	
CINx Input Range		$\pm 8$		pF	
No Missing Codes	16			Bits	Guaranteed by design, but not production tested
CINx Input Leakage		25		nA	
Maximum Output Load			20	pF	Capacitance load on CINx to ground
Total Unadjusted Error			$\pm 20$	%	
Output Noise (Peak-to-Peak)		12		Codes	Decimation rate = 64
		7		Codes	Decimation rate = 128
		3		Codes	Decimation rate = 256
Output Noise (RMS)		1.1		Codes	Decimation rate = 64
		0.8		Codes	Decimation rate = 128
		0.5		Codes	Decimation rate = 256
C <sub>STRAY</sub> Offset Range		20		pF	
C <sub>STRAY</sub> Offset Resolution		0.32		pF	
Low Power Mode Delay Accuracy			4	%	Percentage of 200 ms, 400 ms, 600 ms, or 800 ms
<b>AC<sub>SHIELD</sub></b>					
Frequency		250		kHz	
Output Voltage	0		V <sub>CC</sub>	V	Oscillating
Short-Circuit Source Current		10		mA	
Short-Circuit Sink Current		10		mA	
Maximum Output Load			150	pF	Capacitance load on AC <sub>SHIELD</sub> to ground
<b>LOGIC INPUTS (SDI, SCLK, CS, SDA, GPIO)</b>					
Input High Voltage, V <sub>IH</sub>	$0.7 \times V_{DRIVE}$			V	
Input Low Voltage, V <sub>IL</sub>			0.4	V	
Input High Current, I <sub>IH</sub>	-1			$\mu\text{A}$	V <sub>IN</sub> = V <sub>DRIVE</sub>
Input Low Current, I <sub>IL</sub>			1	$\mu\text{A}$	V <sub>IN</sub> = GND
Hysteresis		150		mV	
<b>OPEN-DRAIN OUTPUTS (SCLK, SDA, INT)</b>					
Output Low Voltage, V <sub>OL</sub>			0.4	V	I <sub>SINK</sub> = -1 mA
Output High Leakage Current, I <sub>OH</sub>		$\pm 0.1$	$\pm 1$	$\mu\text{A}$	V <sub>OUT</sub> = V <sub>DRIVE</sub>
<b>LOGIC OUTPUTS (SDO, GPIO)</b>					
Output Low Voltage, V <sub>OL</sub>			0.4	V	I <sub>SINK</sub> = 1 mA, V <sub>DRIVE</sub> = 1.65 V to 3.6 V
Output High Voltage, V <sub>OH</sub>	V <sub>DRIVE</sub> - 0.6			V	I <sub>SOURCE</sub> = 1 mA, V <sub>DRIVE</sub> = 1.65 V to 3.6 V
GPO, SDO Floating State Leakage Current			$\pm 1$	$\mu\text{A}$	Pin three-state, leakage measured to GND and V <sub>CC</sub>
<b>POWER</b>					
V <sub>CC</sub>	2.6	3.3	3.6	V	
V <sub>DRIVE</sub>	1.65		3.6	V	Serial interface operating voltage
I <sub>CC</sub>		0.8	1	mA	In full power mode, V <sub>CC</sub> + V <sub>DRIVE</sub> , Register 0x00, Bits[15:14] = 00
		1.1	1.3	mA	In full power mode, V <sub>CC</sub> + V <sub>DRIVE</sub> , Register 0x00, Bits[15:14] = 01
		1.2	1.5	mA	In full power mode, V <sub>CC</sub> + V <sub>DRIVE</sub> , Register 0x00, Bits[15:14] = 10
		1.6	1.8	mA	In full power mode, V <sub>CC</sub> + V <sub>DRIVE</sub> , Register 0x00, Bits[15:14] = 11
		15.5	24	$\mu\text{A}$	Low power mode, converter idle, V <sub>CC</sub> + V <sub>DRIVE</sub> , decimation = 256; Register 0x00, Bits[15:14] = 01
		2.3	10	$\mu\text{A}$	Full shutdown, V <sub>CC</sub> + V <sub>DRIVE</sub> , Register 0x00, Bits[15:14] = 01

# AD7147A

## AVERAGE CURRENT SPECIFICATIONS

Table 2. Typical Average Current in Low Power Mode<sup>1</sup>

Low Power Mode Delay	Decimation Rate	Current Values of Conversion Stages (µA)											
		1	2	3	4	5	6	7	8	9	10	11	12
200 ms	64	22.27	26.53	30.77	34.98	39.15	43.29	47.40	51.48	55.53	59.55	63.54	67.51
	128	27.95	36.37	44.66	52.84	60.89	68.82	76.64	84.34	91.94	99.42	106.80	114.08
	256	39.15	55.53	71.44	86.89	101.9	116.48	130.67	144.47	157.90	170.98	183.71	196.11
400 ms	64	18.89	21.04	23.19	25.32	27.45	29.57	31.68	33.78	35.88	37.96	40.04	42.11
	128	21.76	26.03	30.27	34.48	38.66	42.80	46.92	51.00	55.05	59.08	63.07	67.04
	256	27.45	35.88	44.18	52.36	60.41	68.35	76.18	83.89	91.49	98.98	106.37	113.65
600 ms	64	17.76	19.20	20.63	22.06	23.49	24.91	26.33	27.75	29.16	30.57	31.98	33.38
	128	19.68	22.54	25.39	28.22	31.04	33.85	36.64	39.42	42.18	44.93	47.67	50.39
	256	23.49	29.16	34.78	40.34	45.84	51.29	56.69	62.03	67.32	72.56	77.75	82.89
800 ms	64	17.20	18.28	19.35	20.43	21.50	22.57	23.64	24.71	25.78	26.84	27.90	28.96
	128	18.63	20.79	22.93	25.07	27.20	29.32	31.43	33.53	35.63	37.72	39.80	41.87
	256	21.50	25.78	30.02	34.23	38.41	42.56	46.67	50.76	54.82	58.84	62.84	66.80

<sup>1</sup> V<sub>CC</sub> = 3.3 V, T<sub>A</sub> = 25°C, load = 50 pF.

Table 3. Maximum Average Current in Low Power Mode<sup>1</sup>

Low Power Mode Delay	Decimation Rate	Current Values of Conversion Stages (µA)											
		1	2	3	4	5	6	7	8	9	10	11	12
200 ms	64	32.62	38.12	43.58	48.99	54.35	59.67	64.95	70.18	75.37	80.52	85.63	90.69
	128	39.95	50.78	61.44	71.92	82.23	92.37	102.36	112.18	121.85	131.27	140.74	149.97
	256	54.35	75.37	95.72	115.42	134.51	153.02	170.96	188.38	205.28	221.70	237.65	253.15
400 ms	64	28.32	31.10	33.86	36.61	39.35	42.08	44.80	47.50	50.19	52.88	55.55	58.21
	128	32.02	37.53	42.99	48.40	53.77	59.09	64.38	69.61	74.81	79.96	85.07	90.14
	256	39.35	50.19	60.86	71.35	81.67	91.82	101.82	111.65	121.33	130.86	140.24	149.47
600 ms	64	26.88	28.74	30.59	32.43	34.27	36.11	37.94	39.76	41.58	43.39	45.20	47.00
	128	29.36	33.05	36.72	40.37	44.00	47.60	51.19	54.76	58.31	61.84	65.35	68.84
	256	34.27	41.58	48.80	55.95	63.01	70.00	76.92	83.76	90.52	97.21	103.83	110.39
800 ms	64	26.16	27.56	28.95	30.33	31.72	33.10	34.48	35.85	37.23	38.60	39.96	41.33
	128	28.02	30.80	33.56	36.31	39.05	41.78	44.50	47.21	49.90	52.59	55.26	57.92
	256	31.72	37.23	42.69	48.11	53.48	58.80	64.09	69.33	74.53	79.68	84.80	89.87

<sup>1</sup> V<sub>CC</sub> = 3.6 V, T<sub>A</sub> = -40°C to +85°C, load = 50 pF.

### SPI TIMING SPECIFICATIONS (AD7147A)

$T_A = -40^{\circ}\text{C}$  to  $+85^{\circ}\text{C}$ , sample tested at  $25^{\circ}\text{C}$  to ensure compliance.  $V_{\text{DRIVE}} = 1.65\text{ V}$  to  $3.6\text{ V}$ , and  $V_{\text{CC}} = 2.6\text{ V}$  to  $3.6\text{ V}$ , unless otherwise noted. All input signals are specified with  $t_R = t_F = 5\text{ ns}$  (10% to 90% of  $V_{\text{CC}}$ ) and timed from a voltage level of  $1.6\text{ V}$ .

**Table 4. SPI Timing Specifications**

Parameter	Limit	Unit	Description
$f_{\text{SCLK}}$	5	MHz max	SCLK frequency
$t_1$	5	ns min	$\overline{\text{CS}}$ falling edge to first SCLK falling edge
$t_2$	20	ns min	SCLK high pulse width
$t_3$	20	ns min	SCLK low pulse width
$t_4$	15	ns min	SDI setup time
$t_5$	15	ns min	SDI hold time
$t_6$	20	ns max	SDO access time after SCLK falling edge
$t_7$	16	ns max	$\overline{\text{CS}}$ rising edge to SDO high impedance
$t_8$	15	ns min	SCLK rising edge to $\overline{\text{CS}}$ high

### SPI Timing Diagram

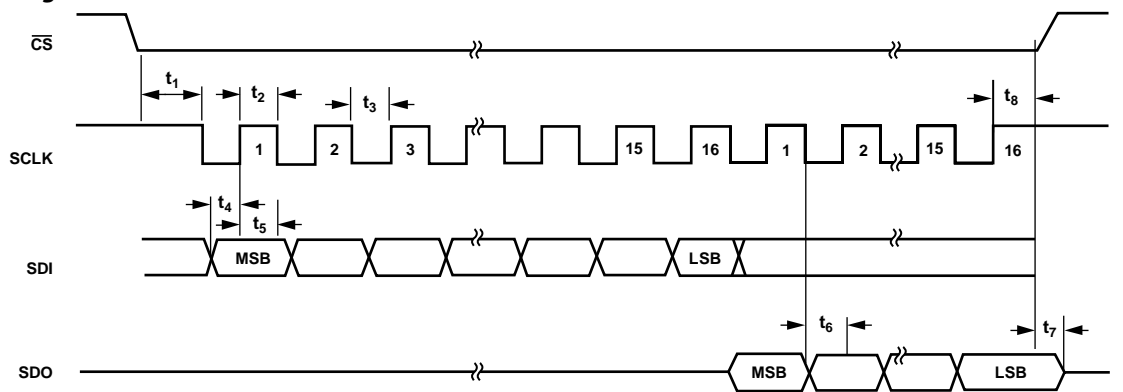

Figure 2. SPI Detailed Timing Diagram

# AD7147A

## I<sup>2</sup>C TIMING SPECIFICATIONS (AD7147A-1)

T<sub>A</sub> = -40°C to +85°C, sample tested at 25°C to ensure compliance. V<sub>DRIVE</sub> = 1.65 V to 3.6 V, and V<sub>CC</sub> = 2.6 V to 3.6 V, unless otherwise noted. All input signals timed from a voltage level of 1.6 V.

Table 5. I<sup>2</sup>C Timing Specifications<sup>1</sup>

Parameter	Limit	Unit	Description
f <sub>SCLK</sub>	400	kHz max	
t <sub>1</sub>	0.6	μs min	Start condition hold time, t <sub>HD;STA</sub>
t <sub>2</sub>	1.3	μs min	Clock low period, t <sub>LOW</sub>
t <sub>3</sub>	0.6	μs min	Clock high period, t <sub>HIGH</sub>
t <sub>4</sub>	100	ns min	Data setup time, t <sub>SU;DAT</sub>
t <sub>5</sub>	300	ns min	Data hold time, t <sub>HD;DAT</sub>
t <sub>6</sub>	0.6	μs min	Stop condition setup time, t <sub>SU;STO</sub>
t <sub>7</sub>	0.6	μs min	Start condition setup time, t <sub>SU;STA</sub>
t <sub>8</sub>	1.3	μs min	Bus-free time between stop and start conditions, t <sub>BUF</sub>
t <sub>R</sub>	300	ns max	Clock/data rise time
t <sub>F</sub>	300	ns max	Clock/data fall time

<sup>1</sup> Guaranteed by design, not production tested.

### I<sup>2</sup>C Timing Diagram

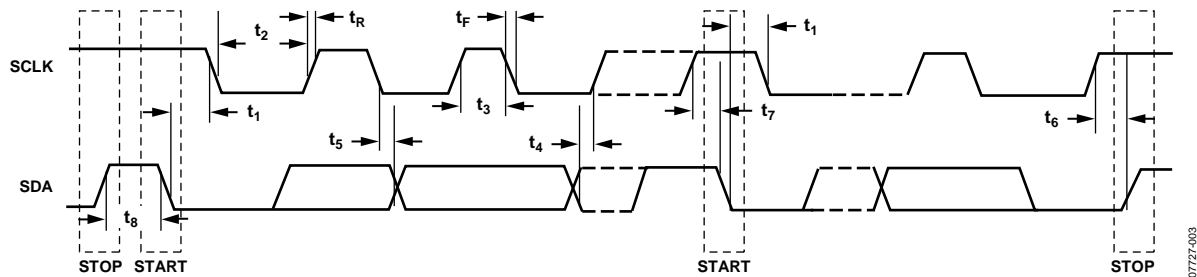

Figure 3. I<sup>2</sup>C Detailed Timing Diagram

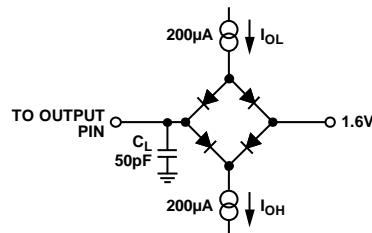

Figure 4. Load Circuit for Digital Output Timing Specifications



## ABSOLUTE MAXIMUM RATINGS

Table 6.

Parameter	Rating
V <sub>CC</sub> to GND	−0.3 V to +3.6 V
Analog Input Voltage to GND	−0.3 V to V <sub>CC</sub> + 0.3 V
Digital Input Voltage to GND	−0.3 V to V <sub>DRIVE</sub> + 0.3 V
Digital Output Voltage to GND	−0.3 V to V <sub>DRIVE</sub> + 0.3 V
Input Current to Any Pin Except Supplies <sup>1</sup>	10 mA
ESD Rating	
BIAS and AC <sub>SHIELD</sub> Pins (HBM Contact and Air Discharge)	8 kV
All Other Pins (HBM Contact)	2 kV
Operating Temperature Range	−40°C to +105°C
Storage Temperature Range	−65°C to +150°C
Junction Temperature	150°C
WLCSP	
Power Dissipation	1 W
θ <sub>JA</sub> Thermal Impedance	65°C/W
IR Reflow Peak Temperature	260°C (± 0.5°C)
Lead Temperature (Soldering, 10 sec)	300°C

<sup>1</sup> Transient currents of up to 100 mA do not cause SCR latch-up.

Stresses above those listed under Absolute Maximum Ratings may cause permanent damage to the device. This is a stress rating only; functional operation of the device at these or any other conditions above those indicated in the operational section of this specification is not implied. Exposure to absolute maximum rating conditions for extended periods may affect device reliability.

### ESD CAUTION



**ESD (electrostatic discharge) sensitive device.** Charged devices and circuit boards can discharge without detection. Although this product features patented or proprietary protection circuitry, damage may occur on devices subjected to high energy ESD. Therefore, proper ESD precautions should be taken to avoid performance degradation or loss of functionality.

## PIN CONFIGURATIONS AND FUNCTION DESCRIPTIONS

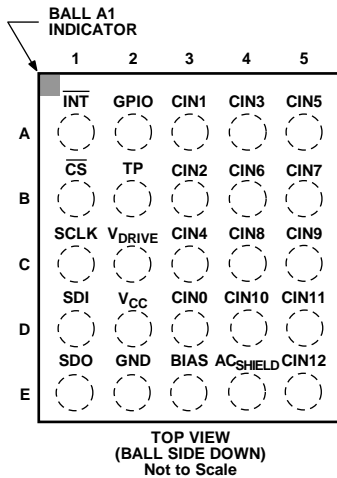

NOTES  
1. TP DENOTES FACTORY TEST POINT.

Figure 5. AD7147A Pin Configuration

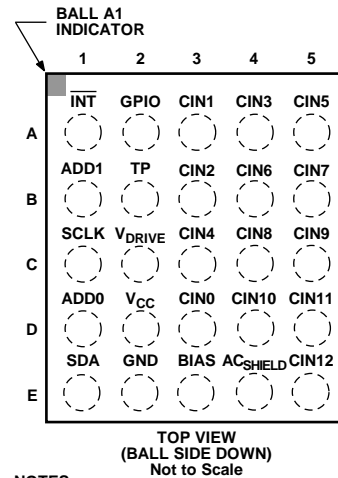

NOTES  
1. TP DENOTES FACTORY TEST POINT.

Figure 6. AD7147A-1 Pin Configuration

Table 7. Pin Function Descriptions

Pin No.		Mnemonic	Description
AD7147A	AD7147A-1		
B4	B4	CIN6	Capacitance Sensor Input.
B5	B5	CIN7	Capacitance Sensor Input.
C4	C4	CIN8	Capacitance Sensor Input.
C5	C5	CIN9	Capacitance Sensor Input.
D4	D4	CIN10	Capacitance Sensor Input.
D5	D5	CIN11	Capacitance Sensor Input.
E5	E5	CIN12	Capacitance Sensor Input.
E4	E4	AC <sub>SHIELD</sub>	CDC Active Shield Output. Connect to external shield or plane.
E3	E3	BIAS	Bias Node for Internal Circuitry. Requires 100 nF capacitor to ground.
E2	E2	GND	Ground Reference Point for All Circuitry.
D2	D2	V <sub>CC</sub>	Supply Voltage.
C2	C2	V <sub>DRIVE</sub>	Serial Interface Operating Voltage Supply.
E1	N/A	SDO	SPI Serial Data Output.
N/A	E1	SDA	I <sup>2</sup> C Serial Data Input/Output. SDA requires pull-up resistor.
D1	N/A	SDI	SPI Serial Data Input.
N/A	D1	ADD0	I <sup>2</sup> C Address Bit 0.
C1	C1	SCLK	Clock Input for Serial Interface.
B1	N/A	$\overline{CS}$	SPI Chip Select Signal.
N/A	B1	ADD1	I <sup>2</sup> C Address Bit 1.
A1	A1	$\overline{INT}$	General-Purpose Open-Drain Interrupt Output. Programmable polarity; requires pull-up resistor.
A2	A2	GPIO	Programmable General-Purpose Input/Output.
D3	D3	CIN0	Capacitance Sensor Input.
A3	A3	CIN1	Capacitance Sensor Input.
B3	B3	CIN2	Capacitance Sensor Input.
A4	A4	CIN3	Capacitance Sensor Input.
C3	C3	CIN4	Capacitance Sensor Input.
A5	A5	CIN5	Capacitance Sensor Input.
B2	B2		Factory Test Point Only. Tie to ground.

# TYPICAL PERFORMANCE CHARACTERISTICS

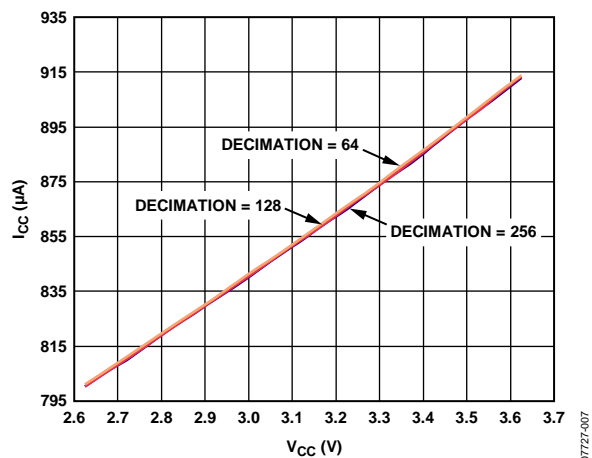

Figure 7. Supply Current vs. Supply Voltage

07727-007

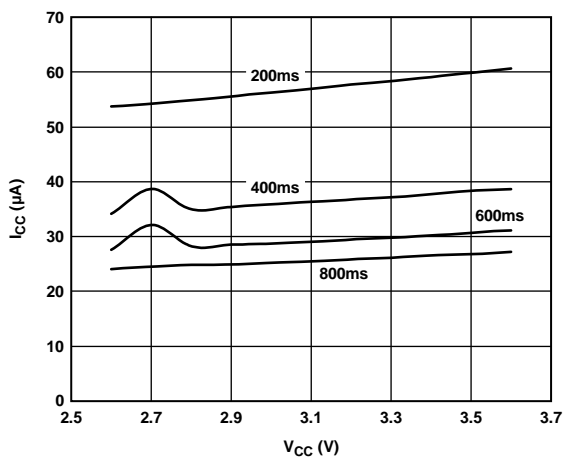

Figure 10. Low Power Supply Current vs. Supply Voltage, Decimation Rate = 64

07727-010

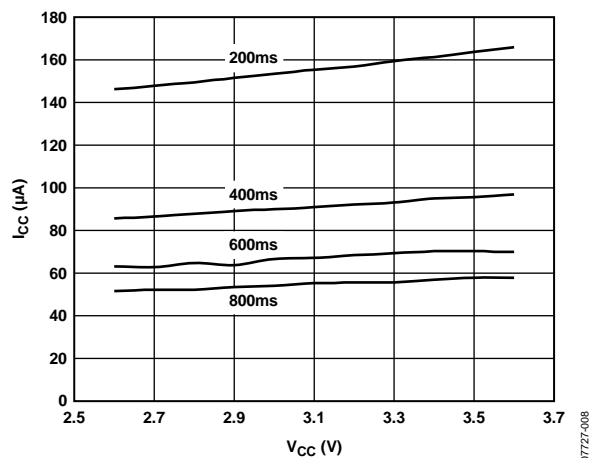

Figure 8. Low Power Supply Current vs. Supply Voltage, Decimation Rate = 256

07727-008

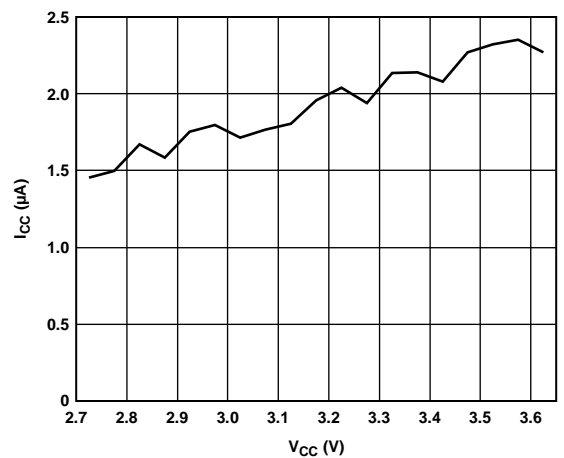

Figure 11. Shutdown Supply Current vs. Supply Voltage

07727-011

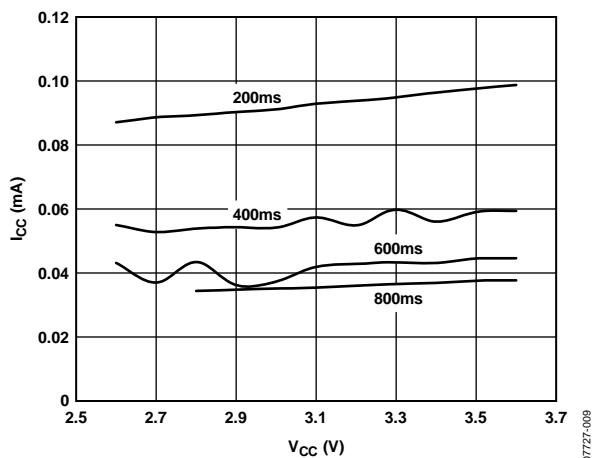

Figure 9. Low Power Supply Current vs. Supply Voltage, Decimation Rate = 128

07727-009

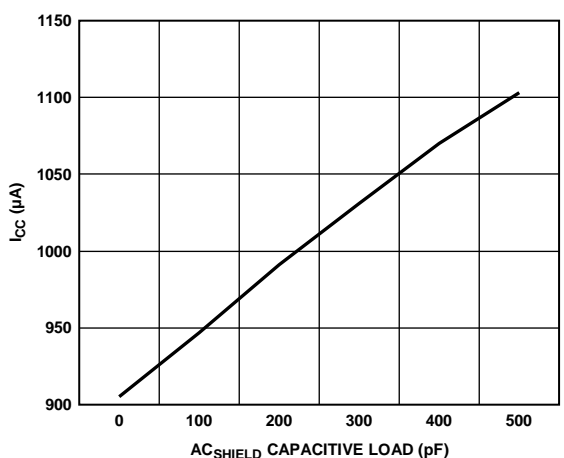

Figure 12. Supply Current vs. Capacitive Load on AC<sub>SHIELD</sub>

07727-012

# AD7147A

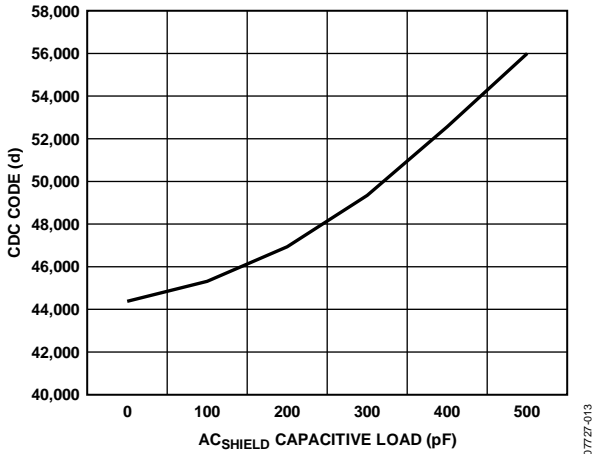

Figure 13. CDC Code vs. Capacitive Load on  $AC_{SHIELD}$

07727-013

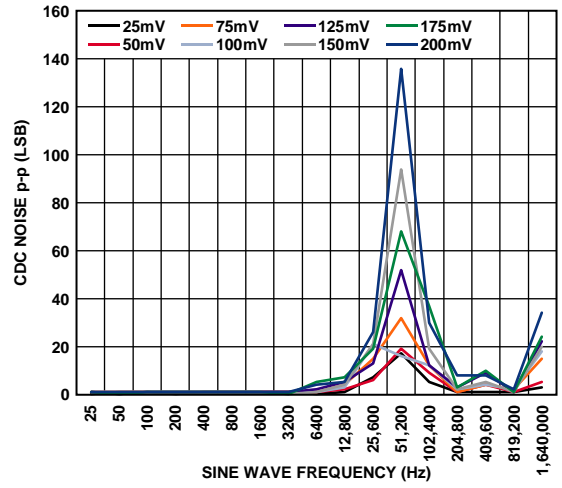

Figure 16. Power Supply Sine Wave Rejection,  $V_{CC} = 3.6 V$

07727-016

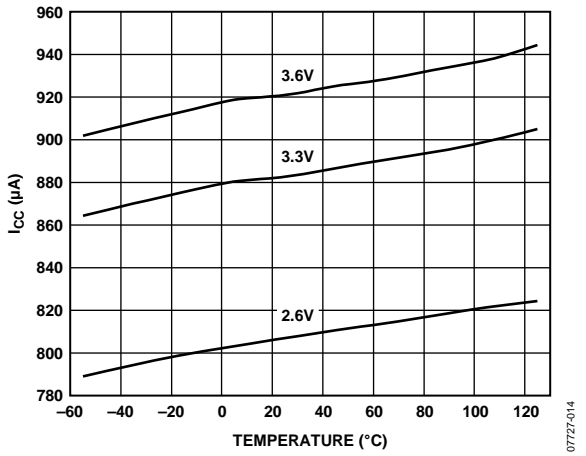

Figure 14. Supply Current vs. Temperature

07727-014

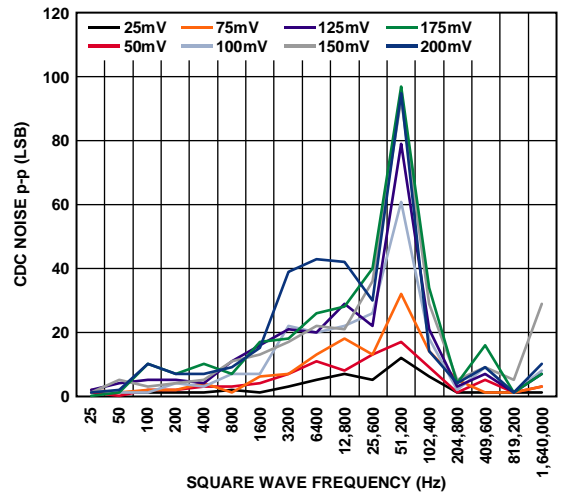

Figure 17. Power Supply Square Wave Rejection,  $V_{CC} = 3.6 V$

07727-017

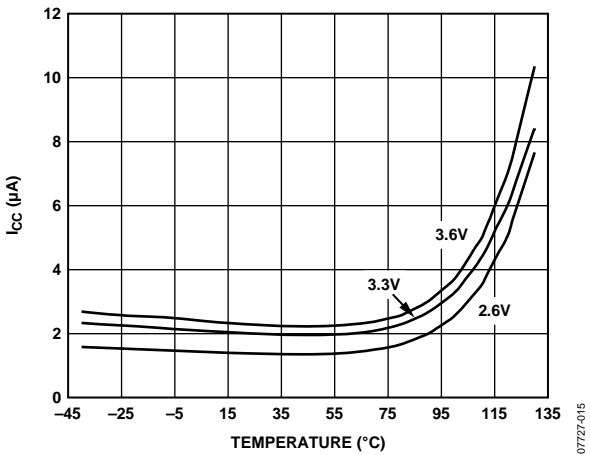

Figure 15. Shutdown Supply Current vs. Temperature

07727-015

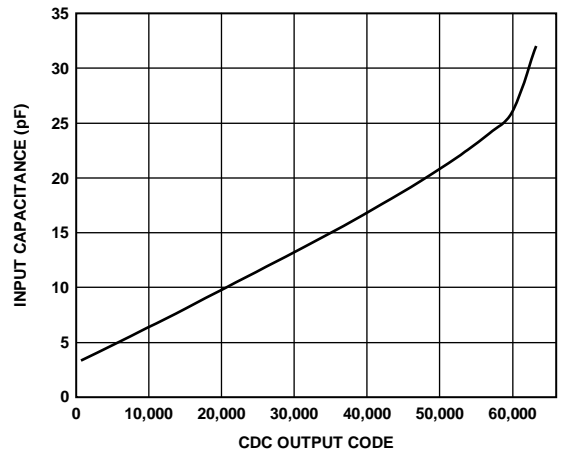

Figure 18. CDC Linearity,  $V_{CC} = 3.3 V$

07727-018

## THEORY OF OPERATION

The AD7147A and AD7147A-1 are CDCs with on-chip environmental compensation. They are intended for use in portable systems requiring high resolution user input. The internal circuitry consists of a 16-bit,  $\Sigma$ - $\Delta$  converter that can change a capacitive input signal into a digital value. There are 13 input pins, CIN0 to CIN12. A switch matrix routes the input signals to the CDC. The result of each capacitance-to-digital conversion is stored in on-chip registers. The host subsequently reads the results over the serial interface. The AD7147A has an SPI interface, and the AD7147A-1 has an I<sup>2</sup>C interface, ensuring that the parts are compatible with a wide range of host processors. AD7147A refers to both the AD7147A and AD7147A-1, unless otherwise noted, from this point forward in this data sheet.

The AD7147A interfaces with up to 13 external capacitance sensors. These sensors can be arranged as buttons, scroll bars, or wheels, or as a combination of sensor types. The external sensors consist of an electrode on a single- or multiple-layer PCB that interfaces directly to the AD7147A.

The AD7147A can be set up to implement any set of input sensors by programming the on-chip registers. The registers can also be programmed to control features such as averaging, offsets, and gains for each of the external sensors. There is an on-chip sequencer that controls how each of the capacitance inputs is polled.

The AD7147A has on-chip digital logic and 528 words of RAM that are used for environmental compensation. The effects of humidity, temperature, and other environmental factors can affect the operation of capacitance sensors. Transparent to the user, the AD7147A performs continuous calibration to compensate for these effects, allowing the AD7147A to consistently provide error-free results.

The AD7147A requires a companion algorithm that runs on the host or another microcontroller to implement high resolution sensor functions, such as scroll bars or wheels. However, no companion algorithm is required to implement buttons. Button sensors are implemented on chip, entirely in digital logic.

The AD7147A can be programmed to operate in either full power mode or low power automatic wake-up mode. The automatic wake-up mode is particularly suited for portable devices that require low power operation to provide the user with significant power savings and full functionality.

The AD7147A has an interrupt output,  $\overline{\text{INT}}$ , to indicate when new data has been placed into the registers.  $\overline{\text{INT}}$  is used to interrupt the host on sensor activation. The AD7147A operates from a 2.6 V to 3.6 V supply and is available in a 2.3 mm  $\times$  2.1 mm WLCSP.

### CAPACITANCE SENSING THEORY

The AD7147A measures capacitance changes from single electrode sensors. The sensor electrode on the PCB comprises one plate of a virtual capacitor. The other plate of the capacitor is the user's finger, which is grounded with respect to the sensor input.

The AD7147A first outputs an excitation signal to charge the plate of the capacitor. When the user comes close to the sensor, the virtual capacitor is formed, with the user acting as the second capacitor plate.

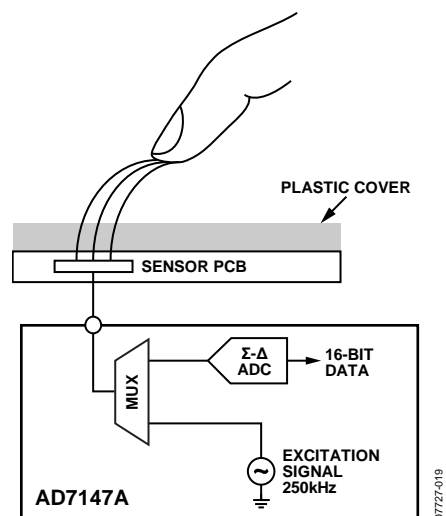

Figure 19. Capacitance-Sensing Method

A square wave excitation signal is applied to CIN<sub>x</sub> during the conversion, and the modulator continuously samples the charge going through CIN<sub>x</sub>. The output of the modulator is processed via a digital filter, and the resulting digital data is stored in the CDC\_RESULT\_S<sub>x</sub> registers for each conversion stage, at Address 0x00B to Address 0x016.

## Registering a Sensor Activation

When a user approaches a sensor, the total capacitance associated with that sensor changes and is measured by the AD7147A. If the change causes a set threshold to be exceeded, the AD7147A interprets this as a sensor activation.

On-chip threshold limits are used to determine when a sensor activation occurs. Figure 20 shows the change in CDC\_RESULT\_Sx when a user activates a sensor. The sensor is deemed to be active only when the value of CDC\_RESULT\_Sx is either greater than the value of STAGEx\_HIGH\_THRESHOLD or less than the value of STAGEx\_LOW\_THRESHOLD.

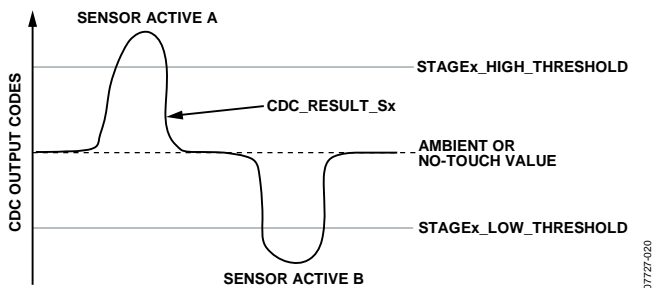

Figure 20. Sensor Activation Thresholds

In Figure 20, two sensor activations are shown. Sensor Active A occurs when a sensor is connected to the positive input of the converter. In this case, when a user activates the sensor, there is an increase in CDC code, and the value of CDC\_RESULT\_Sx exceeds that of STAGEx\_HIGH\_THRESHOLD. Sensor Active B occurs when the sensor is connected to the negative input of the converter. In this case, when a user activates the sensor, there is a decrease in CDC code, and the value of CDC\_RESULT\_Sx becomes less than the value of STAGEx\_LOW\_THRESHOLD.

For each conversion stage, the STAGEx\_HIGH\_THRESHOLD and STAGEx\_LOW\_THRESHOLD registers are in Bank 3. The values in these registers are updated automatically by the AD7147A due to its environmental calibration and adaptive threshold logic.

At power-up, the values in the STAGEx\_HIGH\_THRESHOLD and STAGEx\_LOW\_THRESHOLD registers are the same as those in the STAGEx\_OFFSET\_HIGH and STAGEx\_OFFSET\_LOW registers in Bank 2. The user must program the STAGEx\_OFFSET\_HIGH and STAGEx\_OFFSET\_LOW registers on device power-up. See the Environmental Calibration section of the data sheet for more information.

## Complete Solution for Capacitance Sensing

Analog Devices, Inc., provides a complete solution for capacitance sensing. The two main elements to the solution are the sensor PCB and the AD7147A.

If the application requires high resolution sensors such as scroll bars or wheels, software that runs on the host processor is required. The memory requirements for the host depend on the sensor and are typically 10 kB of code and 600 bytes of data memory, depending on the sensor type.

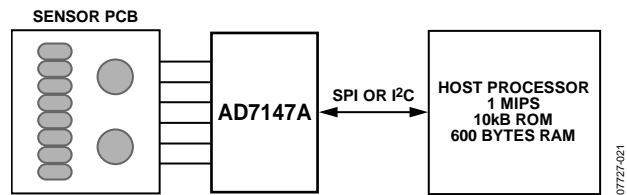

Figure 21. Three-Part Capacitance Sensing Solution

Analog Devices supplies the sensor PCB footprint design libraries to the customer and supplies any necessary software on an open-source basis.

## BIAS PIN

This pin is connected internally to a bias node of the AD7147A. To ensure correct operation of the AD7147A, connect a 100 nF capacitor between the BIAS pin and ground. The voltage seen at the BIAS pin is  $V_{CC}/2$ .

## OPERATING MODES

The AD7147A has three operating modes. Full power mode, where the device is always fully powered, is suited for applications where power is not a concern (for example, game consoles that have an ac power supply). Low power mode, where the part automatically powers down when no sensor is active, is tailored to provide significant power savings compared with full power mode and is suited for mobile applications, where power must be conserved. In shutdown mode, the part shuts down completely.

The POWER\_MODE Bits[1:0] of the power control register (PWR\_CONTROL, Address 0x000) set the operating mode on the AD7147A. Table 8 shows the POWER\_MODE settings for each operating mode. To put the AD7147A into shutdown mode, set the POWER\_MODE bits to either 01 or 11.

Table 8. POWER\_MODE Settings

POWER_MODE Bits	Operating Mode
00	Full power mode
01	Shutdown mode
10	Low power mode
11	Shutdown mode

The power-on default setting of the POWER\_MODE bits is 00, full power mode.

### Full Power Mode

In full power mode, all sections of the AD7147A remain fully powered and converting at all times. While a sensor is being touched, the AD7147A processes the sensor data. If no sensor is touched, the AD7147A measures the ambient capacitance level and uses this data for the on-chip compensation routines. In full power mode, the AD7147A converts at a constant rate. See the CDC Conversion Sequence Time section for more information.

### Low Power Mode

When AD7147A is in low power mode, the POWER\_MODE bits are set to 10 upon device initialization. If the external sensors are not touched, the AD7147A reduces its conversion frequency, thereby greatly reducing its power consumption. The part remains in a reduced power state while the sensors are not touched. The AD7147A performs a conversion after a delay defined by the LP\_CONV\_DELAY bits, and it uses this data to update the compensation logic and check if the sensors are active. The LP\_CONV\_DELAY bits set the delay between conversions to 200 ms, 400 ms, 600 ms, or 800 ms.

In low power mode, the total current consumption of the AD7147A is an average of the current used during a conversion and the current used while the AD7147A is waiting for the next conversion to begin. For example, when LP\_CONV\_DELAY

is 400 ms, the AD7147A typically uses 0.85 mA of current for 36 ms and 14  $\mu$ A of current for 400 ms during the conversion interval. (Note that these conversion timings can be altered through the register settings. See the CDC Conversion Sequence Time section for more information.)

The time for the AD7147A to transition from a full power state to a reduced power state after the user stops touching the external sensors is configurable. The PWR\_DOWN\_TIMEOUT bits in the Ambient Compensation Control 0 register (AMB\_COMP\_CTRL0, Address 0x002) control the time delay before the AD7147A transitions to the reduced power state after the user stops touching the sensors.

### Low Latency from Touch to Response

In low power mode, the AD7147A remains in a low power state until proximity is detected on any one of the external sensors. When proximity is detected, the AD7147A begins a conversion sequence every 9 ms, or 18 ms, or 9 ms to read back data from the sensors. The latency between first touch and AD7147A response is greatly reduced compared to the AD7147 because the part is already in a full power state by the time the user touches the sensor.

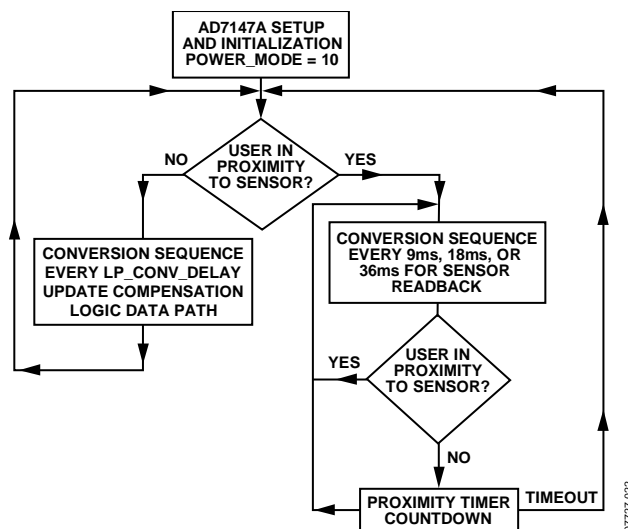

Figure 22. Low Power Mode Operation, AD7147A

## CAPACITANCE-TO-DIGITAL CONVERTER

The capacitance-to-digital converter on the AD7147A has a  $\Sigma$ - $\Delta$  architecture with 16-bit resolution. There are 13 possible inputs to the CDC that are connected to the input of the converter through a switch matrix. The sampling frequency of the CDC is 250 kHz.

### OVERSAMPLING THE CDC OUTPUT

The decimation rate, or oversampling ratio, is determined by Bits[9:8] of the power control register (PWR\_CONTROL, Address 0x000), as listed in Table 9.

**Table 9. CDC Decimation Rate**

Decimation Bits	Decimation Rate	CDC Output Rate Per Stage (ms)
00	256	3.072
01	128	1.536
10	64	0.768
11	64	0.768

The decimation process on the AD7147A is an averaging process, where a number of samples are taken and the averaged result is output. Due to the architecture of the digital filter employed, the number of samples taken (per stage) is equal to  $3 \times$  the decimation rate. So  $3 \times 256$  or  $3 \times 128$  samples are averaged to obtain each stage result.

The decimation process reduces the amount of noise present in the final CDC result. However, the higher the decimation rate, the lower the output rate per stage; therefore, there is a trade-off possible between the amount of noise in the signal and the speed of sampling.

### CAPACITANCE SENSOR OFFSET CONTROL

There are two programmable DACs on board the AD7147A to null the effect of any stray capacitances on the CDC measurement. These offsets are due to stray capacitance to ground.

A simplified block diagram in Figure 23 shows how to apply the STAGEx\_AFE\_OFFSET registers to null the offsets. The POS\_AFE\_OFFSET and NEG\_AFE\_OFFSET bits (Bits[13:8] and Bits[5:0], respectively) program the offset DACs to provide 0.32 pF resolution offset adjustment over a range of 20 pF.

The best practice is to ensure that the CDC output for any stage is approximately equal to midscale ( $\sim 32,700$ ) when all sensors are inactive. To correctly offset the stray capacitance to ground for each stage, use the following procedure:

1. Read back the CDC value from the CDC\_RESULT\_Sx register.
2. If this value is not close to midscale, increase the value of POS\_AFE\_OFFSET or NEG\_AFE\_OFFSET (depending on if the CINx input is connected to the positive or negative input of the converter) by 1. The CINx connections are determined by the STAGEx\_CONNECTION registers.
3. If the CDC value in CDC\_RESULT\_Sx is now closer to midscale, repeat Step 2. If the CDC value is further

from midscale, decrease the POS\_AFE\_OFFSET or NEG\_AFE\_OFFSET value by 1.

The goal is to ensure that the CDC\_RESULT\_Sx is as close to midscale as possible. This process is required only once during the initial capacitance sensor characterization.

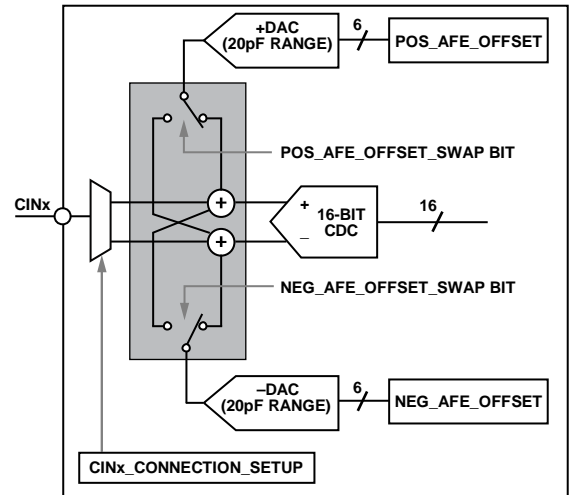

Figure 23. Analog Front-End Offset Control

### CONVERSION SEQUENCER

The AD7147A has an on-chip sequencer to implement conversion control for the input channels. Up to 12 conversion stages can be performed in one sequence. Each of the 12 conversions stages can measure the input from a different sensor. By using the Bank 2 registers, each stage can be uniquely configured to support multiple capacitance sensor interface requirements. For example, a slider sensor can be assigned to STAGE1 through STAGE8, with a button sensor assigned to STAGE0. For each conversion stage, the input mux that connects the CINx inputs to the converter can have a unique setting.

The AD7147A on-chip sequence controller provides conversion control, beginning with STAGE0. Figure 24 shows a block diagram of the CDC conversion stages and CINx inputs. A conversion sequence is defined as a sequence of CDC conversions starting at STAGE0 and ending at the stage determined by the value programmed in the SEQUENCE\_STAGE\_NUM bits (Bits[7:4], Address 0x00). Depending on the number and type of capacitance sensors that are used, not all conversion stages are required. Use the SEQUENCE\_STAGE\_NUM bits to set the number of conversions in one sequence. This number depends on the sensor interface requirements. For example, the register should be set to 5 if the CINx inputs are mapped to only six conversion stages. In addition, the STAGE\_CAL\_EN register (Address 0x001) should be set according to the number of stages that are used.

The number of required conversion stages depends solely on the number of sensors attached to the AD7147A. Figure 25 shows how many conversion stages are required for each sensor and how many inputs to the AD7147A each sensor requires.



A button sensor generally requires one sequencer stage; this is shown in Figure 25 as B1. However, it is possible to configure two button sensors to operate differentially for one conversion stage. Only one button can be activated at a time; pressing both buttons simultaneously results in neither button being activated. The configuration with two button sensors operating differentially requires one conversion stage and is shown in Figure 25, with B2 and B3 representing the differentially configured button sensors.

A wheel sensor requires eight stages, whereas a slider requires two stages. The result from each stage is used by the host software to determine the user's position on the slider or wheel. The algorithms that perform this process are available from Analog Devices and are free of charge but require signing a software license.

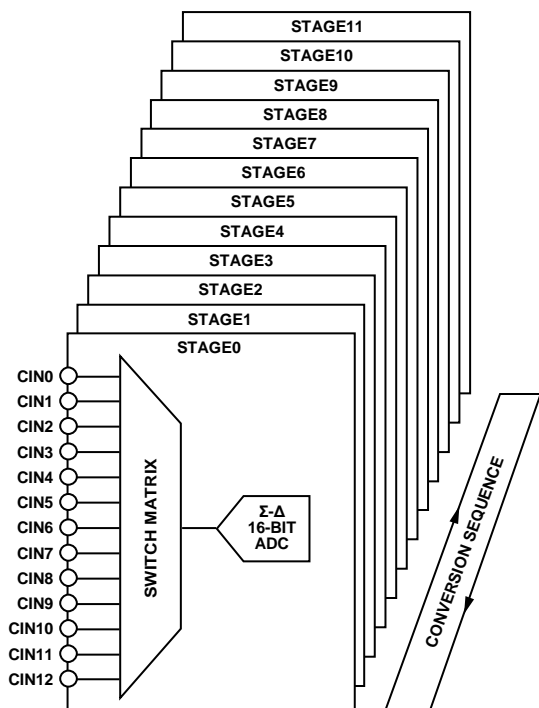

Figure 24. CDC Conversion Stages

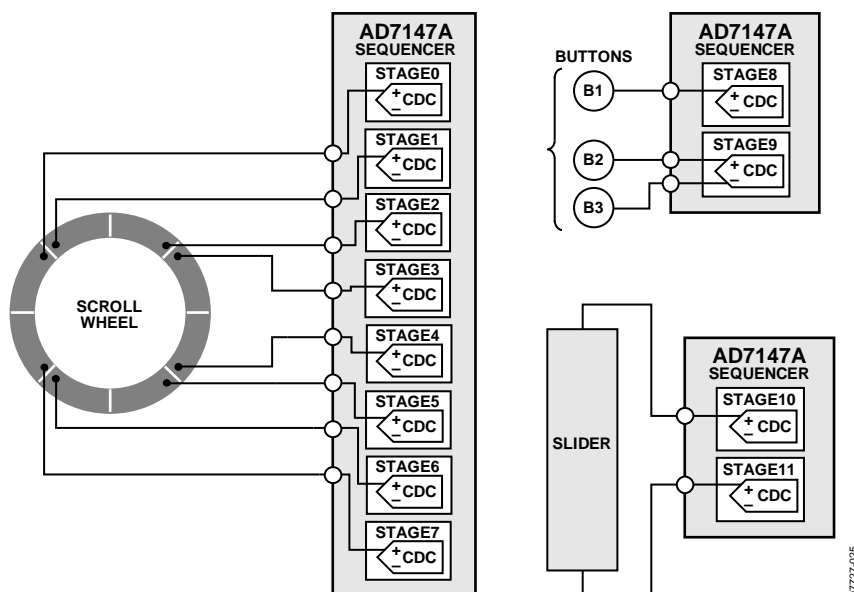

Figure 25. Sequencer Setup for Sensors

## CDC CONVERSION SEQUENCE TIME

Table 10. CDC Conversion Times for Full Power Mode

SEQUENCE_STAGE_NUM	Conversion Time (ms)		
	Decimation = 64	Decimation = 128	Decimation = 256
0	0.768	1.536	3.072
1	1.536	3.072	6.144
2	2.304	4.608	9.216
3	3.072	6.144	12.288
4	3.84	7.68	15.36
5	4.608	9.216	18.432
6	5.376	10.752	21.504
7	6.144	12.288	24.576
8	6.912	13.824	27.648
9	7.68	15.36	30.72
10	8.448	16.896	33.792
11	9.216	18.432	36.864

The time required for the CDC to complete the measurement of all 12 stages is defined as the CDC conversion sequence time. The SEQUENCE\_STAGE\_NUM and DECIMATION bits determine the conversion time, as listed in Table 10.

For example, if the device is operated with a decimation rate of 128 and the SEQUENCE\_STAGE\_NUM bit is set to 5 for the conversion of six stages in a sequence, the conversion sequence time is 9.216 ms.

### Full Power Mode CDC Conversion Sequence Time

The full power mode CDC conversion sequence time for all 12 stages is set by configuring the SEQUENCE\_STAGE\_NUM and DECIMATION bits as outlined in Table 10.

Figure 26 shows a simplified timing diagram of the full power mode CDC conversion time. The full power mode CDC conversion time ( $t_{CONV\_FP}$ ) is set using the values shown in Table 10.

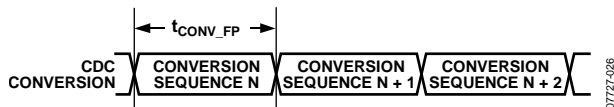

Figure 26. Full Power Mode CDC Conversion Sequence Time

### Low Power Mode CDC Conversion Sequence Time with Delay

The frequency of each CDC conversion while operating in the low power automatic wake-up mode is controlled by using the LP\_CONV\_DELAY Bits[3:2] located at Address 0x000 in addition to the registers listed in Table 10. This feature provides some flexibility for optimizing the trade-off between the conversion time needed to meet system requirements and the power consumption of the AD7147A.

For example, maximum power savings is achieved when the LP\_CONV\_DELAY bits are set to 11. With a setting of 11, the AD7147A automatically wakes up, performing a conversion every 800 ms.

Table 11. LP\_CONV\_DELAY Settings

LP_CONV_DELAY Bits	Delay Between Conversions (ms)
00	200
01	400
10	600
11	800

Figure 27 shows a simplified timing example of the low power mode CDC conversion time. As shown, the low power mode CDC conversion time is set by  $t_{CONV\_FP}$  and the LP\_CONV\_DELAY bits.

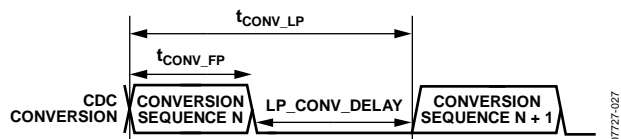

Figure 27. Low Power Mode CDC Conversion Sequence Time

## CDC CONVERSION RESULTS

Certain high resolution sensors require the host to read back the CDC conversion results for processing. The registers required for host processing are located in Bank 3. The host processes the data read back from these registers using a software algorithm to determine position information.

In addition to the results registers in Bank 3, the AD7147A provides the 16-bit CDC output data directly, starting at Address 0x00B of Bank 1. Reading back the CDC 16-bit conversion data register allows for customer-specific application data processing.

## CAPACITANCE SENSOR INPUT CONFIGURATION

Each input connection from the external capacitance sensors to the converter of the AD7147A can be uniquely configured by using the stage configuration registers in Bank 2 (see Table 39). These registers are used to configure the input pin connection setups, sensor offsets, sensor sensitivities, and sensor limits for each stage. Each sensor can be individually optimized. For example, a button sensor connected to STAGE0 can have different sensitivity and offset values than a button with another function that is connected to a different stage.

### CIN<sub>x</sub> INPUT MULTIPLEXER SETUP

Table 35 and Table 36 list the available options for the CIN<sub>x</sub>\_CONNECTION\_SETUP bits when the sensor input pins are connected to the CDC.

The AD7147A has an on-chip multiplexer that routes the input signals from each CIN<sub>x</sub> pin to the input of the converter. Each input pin can be tied to either the negative or positive input of the CDC, or it can be left floating. Each input can also be internally connected to the BIAS signal to help prevent cross-coupling. If an input is not used, always connect it to BIAS.

Connecting a CIN<sub>x</sub> input pin to the positive CDC input results in an increase in CDC output code when the corresponding sensor is activated. Connecting a CIN<sub>x</sub> input pin to the negative CDC input results in a decrease in CDC output code when the corresponding sensor is activated.

The AD7147A performs a sequence of 12 conversions. The multiplexer can have different settings for each of the 12 conversions. For example, CIN<sub>0</sub> is connected to the negative CDC input for conversion STAGE1, left floating for conversion STAGE1, and so on, for all 12 conversion stages.

For each CIN<sub>x</sub> input for each conversion stage, two bits control how the input is connected to the converter, as shown in Figure 28.

### Examples

To connect CIN<sub>3</sub> to the positive CDC input on Stage 0, use the following setting:

```
STAGE0_CONNECTION[6:0] = 0xFFBF
STAGE0_CONNECTION[12:7] = 0x2FFF
```

To connect CIN<sub>0</sub> to the positive CDC input and CIN<sub>12</sub> to the negative CIN input on STAGE5, use the following settings:

```
STAGE5_CONNECTION[6:0] = 0xFFFE
STAGE5_CONNECTION[12:7] = 0x37FF
```

### SINGLE-ENDED CONNECTIONS TO THE CDC

A single-ended connection to the CDC is defined as one CIN<sub>x</sub> input connected to either the positive or negative CDC input for one conversion stage. A differential connection to the CDC is defined as one CIN<sub>x</sub> input connected to the positive CDC input and a second CIN<sub>x</sub> input connected to the negative input of the CDC for one conversion stage.

For any stage, if a single-ended connection to the CDC is made in that stage, the SE\_CONNECTION\_SETUP Bits[13:12] in the STAGE<sub>x</sub>\_CONNECTION[12:7] register should be applied as described in Table 12.

**Table 12. SE\_CONNECTION\_SETUP Bits**

SE_CONNECTION_SETUP	Description
00	Do not use.
01	Single-ended connection. For this stage, there is one CIN <sub>x</sub> connected to the positive CDC input.
10	Single-ended connection. For this stage, there is one CIN <sub>x</sub> connected to the negative CDC input.
11	Differential connection. For this stage, there is one CIN <sub>x</sub> connected to the negative CDC input and one CIN <sub>x</sub> connected to the positive CDC input.

The SE\_CONNECTION\_SETUP Bits[13:12] ensure that during a single-ended connection to the CDC, the input paths to both CDC terminals are matched, which, in turn, improves the power-supply rejection of the converter measurement.

These bits should be applied in addition to setting the other bits in the STAGE<sub>x</sub>\_CONNECTION registers, as outlined in the CIN<sub>x</sub> Input Multiplexer Setup section.

If more than one CIN<sub>x</sub> input is connected to either the positive or negative input of the converter for the same conversion, set SE\_CONNECTION\_SETUP to 11. For example, if CIN<sub>0</sub> and CIN<sub>3</sub> are connected to the positive input of the CDC, set SE\_CONNECTION\_SETUP to 11.

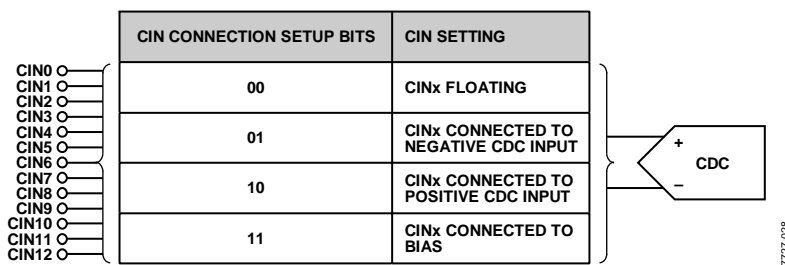

Figure 28. Input Mux Configuration Options

## NONCONTACT PROXIMITY DETECTION

The AD7147A internal signal processing continuously monitors all capacitance sensors for noncontact proximity detection. This feature provides the ability to detect when a user is approaching a sensor, at which time all internal calibration is immediately disabled while the AD7147 is automatically configured to detect a valid contact.

The proximity control register bits are described in Table 13. The FP\_PROXIMITY\_CNT and LP\_PROXIMITY\_CNT register bits control the length of the calibration disable period after the user stops touching the sensor and is not in close proximity to the sensor during full or low power mode. The calibration is disabled during this period and then enabled again. Figure 29 and Figure 30 show examples of how these register bits are used to set the calibration disable periods for the full and low power modes.

The calibration disable period in full power mode is the value of the FP\_PROXIMITY\_CNT multiplied by 16 multiplied by the time for one conversion sequence in full power mode. The calibration disable period in low power mode is the value of the LP\_PROXIMITY\_CNT multiplied by 4 multiplied by the time for one conversion sequence in low power mode.

### RECALIBRATION

In certain situations, for example, when a user hovers over a sensor for a long time, the proximity flag can be set for a long period. The environmental calibration on the AD7147A is suspended while proximity is detected, but changes may occur to the ambient capacitance level during the proximity event. This means that the ambient value stored on the AD7147A no longer represents the actual ambient value. In this case, even when the user is not in close proximity to the sensor, the proximity flag may still be set. This situation can occur if the user interaction creates some moisture on the sensor, causing the new sensor ambient value to be different from the expected value. In this situation, the AD7147A automatically forces a recalibration internally. This ensures that the ambient values are recalibrated, regardless of how long the user hovers over the sensor. A recalibration ensures maximum AD7147A sensor performance.

The AD7147A recalibrates automatically when the measured CDC value exceeds the stored ambient value by an amount determined by the PROXIMITY\_RECAL\_LVL bits for a set period of time known as the recalibration timeout. In full power mode, the recalibration timeout is controlled by FP\_PROXIMITY\_RECAL; in low power mode, by LP\_PROXIMITY\_RECAL.

The recalibration timeout in full power mode is the value of FP\_PROXIMITY\_RECAL multiplied by the time for one conversion sequence in full power mode. The recalibration timeout in low power mode is the value of LP\_PROXIMITY\_RECAL multiplied by the time for one conversion sequence in low power mode.

Figure 31 and Figure 32 show examples of how the FP\_PROXIMITY\_RECAL and LP\_PROXIMITY\_RECAL register bits control the timeout period before a recalibration while operating in the full and low power modes. In these examples, a user approaches a sensor and then leaves, but the proximity detection remains active. The measured CDC value exceeds the stored ambient value by the amount set in the PROXIMITY\_RECAL\_LVL bits for the entire timeout period. The sensor is automatically recalibrated at the end of the timeout period.

### PROXIMITY SENSITIVITY

The fast filter in Figure 33 is used to detect when someone is close to the sensor (proximity). Two conditions, detected by Comparator 1 and Comparator 2, set the internal proximity detection signal: Comparator 1 detects when a user is approaching or leaving a sensor, and Comparator 2 detects when a user hovers over a sensor or approaches a sensor very slowly.

The sensitivity of Comparator 1 is controlled by the PROXIMITY\_DETECTION\_RATE bits (Address 0x003). For example, if PROXIMITY\_DETECTION\_RATE is set to 4, the Proximity 1 signal is set when the absolute difference between WORD1 and WORD3 exceeds  $(4 \times 16)$  LSB codes.

The PROXIMITY\_RECAL\_LVL bits (Address 0x003) control the sensitivity of Comparator 2. For example, if PROXIMITY\_RECAL\_LVL is set to 75, the Proximity 2 signal is set when the absolute difference between the fast filter average value and the ambient value exceeds  $(75 \times 16)$  LSB codes.

Table 13. Proximity Control Registers (See Figure 33)

Bit Name	Length (Bits)	Register Address	Description
FP_PROXIMITY_CNT	4	0x002[7:4]	Calibration disable time in full power mode.
LP_PROXIMITY_CNT	4	0x002[11:8]	Calibration disable time in low power mode.
FP_PROXIMITY_RECAL	10	0x004[9:0]	Full power mode proximity recalibration time control.
LP_PROXIMITY_RECAL	6	0x004[15:10]	Low power mode proximity recalibration time control.
PROXIMITY_RECAL_LVL	8	0x003[7:0]	Proximity recalibration level. This value, multiplied by 16, controls the sensitivity of Comparator 2 (see Figure 33).
PROXIMITY_DETECTION_RATE	6	0x003[13:8]	Proximity detection rate. This value, multiplied by 16, controls the sensitivity of Comparator 1 (see Figure 33).

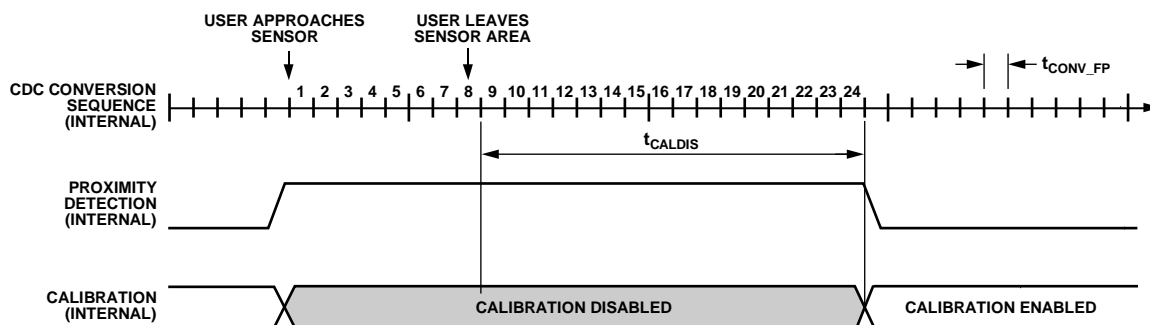
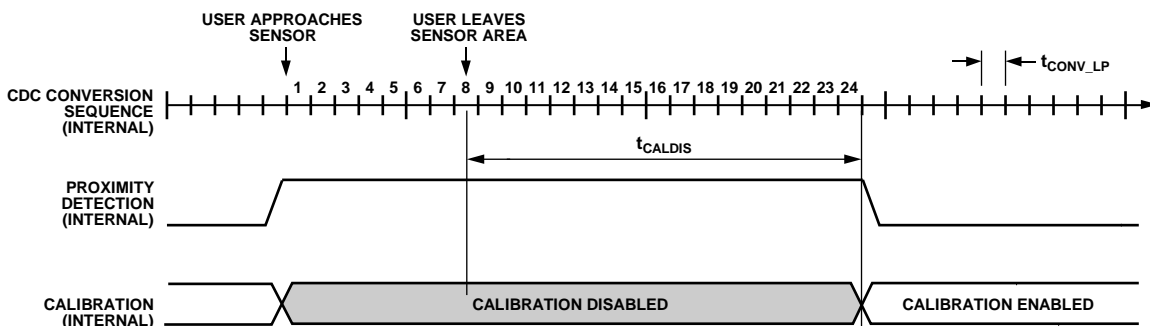
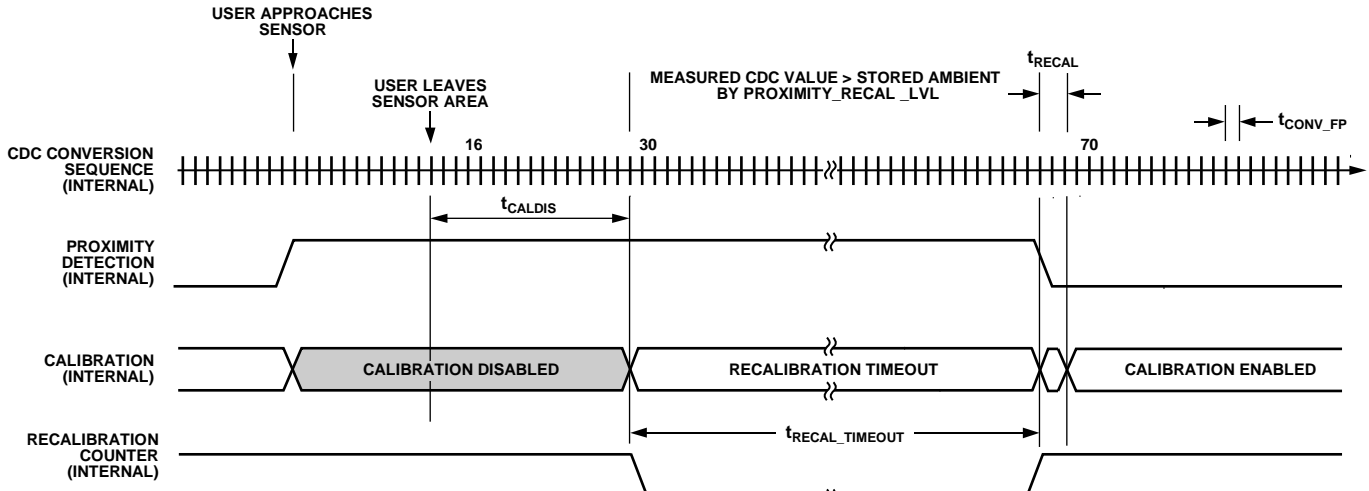

Figure 29. Example of Full Power Mode Proximity Detection (FP\_PROXIMITY\_CNT = 1)



- NOTES
1. SEQUENCE CONVERSION TIME  $t_{CONV\_LP} = t_{CONV\_FP} + LP\_CONV\_DELAY$ .
  2. PROXIMITY IS SET WHEN THE USER APPROACHES THE SENSOR, AT WHICH TIME THE INTERNAL CALIBRATION IS DISABLED.
  3.  $t_{CALDIS} = (t_{CONV\_LP} \times LP\_PROXIMITY\_CNT \times 4)$ .

Figure 30. Example of Low Power Mode Proximity Detection (LP\_PROXIMITY\_CNT = 4)



- NOTES**
1. SEQUENCE CONVERSION TIME  $t_{CONV\_FP}$  (SEE TABLE 10).
  2.  $t_{CALDIS} = t_{CONV\_FP} \times FP\_PROXIMITY\_CNT \times 16$ .
  3.  $t_{RECAL\_TIMEOUT} = t_{CONV\_FP} \times FP\_PROXIMITY\_RECAL$ .
  4.  $t_{RECAL} = 2 \times t_{CONV\_FP}$ .

Figure 31. Example of Full Power Mode Proximity Detection with Forced Recalibration ( $FP\_PROXIMITY\_CNT = 1$  and  $FP\_PROXIMITY\_RECAL = 40$ )

07727-031

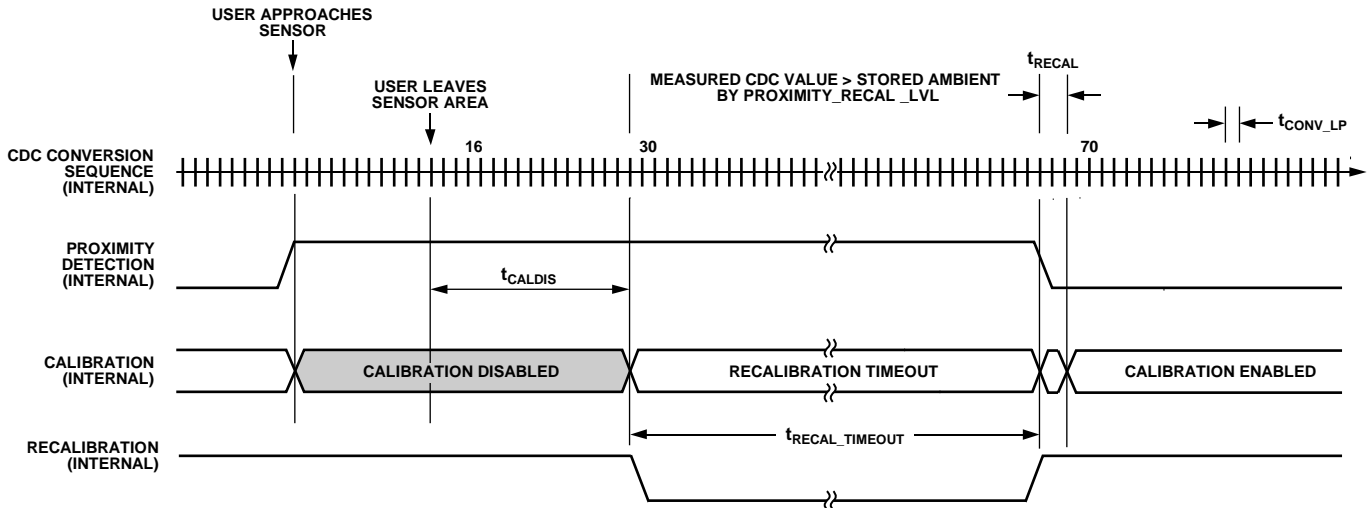

- NOTES**
1. SEQUENCE CONVERSION TIME  $t_{CONV\_LP} = t_{CONV\_FP} + LP\_CONV\_DELAY$ .
  2.  $t_{CALDIS} = t_{CONV\_LP} \times LP\_PROXIMITY\_CNT \times 4$ .
  3.  $t_{RECAL\_TIMEOUT} = t_{CONV\_LP} \times LP\_PROXIMITY\_RECAL$ .
  4.  $t_{RECAL} = 2 \times t_{CONV\_LP}$ .

Figure 32. Example of Low Power Mode Proximity Detection with Forced Recalibration ( $LP\_PROXIMITY\_CNT = 4$  and  $LP\_PROXIMITY\_RECAL = 40$ )

07727-032

**FF\_SKIP\_CNT**

The proximity detection fast FIFO is used by the on-chip logic to determine if proximity is detected. The fast FIFO expects to receive samples from the converter at a set rate. The fast filter skip control, FF\_SKIP\_CNT (Bits[3:0], Address 0x002), is used to normalize the frequency of the samples going into the FIFO, regardless of how many conversion stages are in a sequence. This value determines which CDC samples are not used (skipped) by the proximity detection fast FIFO.

Determining the FF\_SKIP\_CNT value is required only once during the initial setup of the capacitance sensor interface. Table 13 shows how FF\_SKIP\_CNT controls the update rate of the fast FIFO. The recommended value for the setting when using all 12 conversion stages on the AD7147A is 0000, or no samples skipped.

**Table 14. FF\_SKIP\_CNT Settings**

FF_SKIP_CNT	FAST FIFO Update Rate		
	Decimation = 64	Decimation = 128	Decimation = 256
0	$0.768 \times (\text{SEQUENCE\_STAGE\_NUM} + 1)$ ms	$1.536 \times (\text{SEQUENCE\_STAGE\_NUM} + 1)$ ms	$3.072 \times (\text{SEQUENCE\_STAGE\_NUM} + 1)$ ms
1	$1.536 \times (\text{SEQUENCE\_STAGE\_NUM} + 1)$ ms	$3.072 \times (\text{SEQUENCE\_STAGE\_NUM} + 1)$ ms	$6.144 \times (\text{SEQUENCE\_STAGE\_NUM} + 1)$ ms
2	$2.304 \times (\text{SEQUENCE\_STAGE\_NUM} + 1)$ ms	$4.608 \times (\text{SEQUENCE\_STAGE\_NUM} + 1)$ ms	$9.216 \times (\text{SEQUENCE\_STAGE\_NUM} + 1)$ ms
3	$3.072 \times (\text{SEQUENCE\_STAGE\_NUM} + 1)$ ms	$6.144 \times (\text{SEQUENCE\_STAGE\_NUM} + 1)$ ms	$12.288 \times (\text{SEQUENCE\_STAGE\_NUM} + 1)$ ms
4	$3.84 \times (\text{SEQUENCE\_STAGE\_NUM} + 1)$ ms	$7.68 \times (\text{SEQUENCE\_STAGE\_NUM} + 1)$ ms	$15.36 \times (\text{SEQUENCE\_STAGE\_NUM} + 1)$ ms
5	$4.608 \times (\text{SEQUENCE\_STAGE\_NUM} + 1)$ ms	$9.216 \times (\text{SEQUENCE\_STAGE\_NUM} + 1)$ ms	$18.432 \times (\text{SEQUENCE\_STAGE\_NUM} + 1)$ ms
6	$5.376 \times (\text{SEQUENCE\_STAGE\_NUM} + 1)$ ms	$10.752 \times (\text{SEQUENCE\_STAGE\_NUM} + 1)$ ms	$21.504 \times (\text{SEQUENCE\_STAGE\_NUM} + 1)$ ms
7	$6.144 \times (\text{SEQUENCE\_STAGE\_NUM} + 1)$ ms	$12.288 \times (\text{SEQUENCE\_STAGE\_NUM} + 1)$ ms	$24.576 \times (\text{SEQUENCE\_STAGE\_NUM} + 1)$ ms
8	$6.912 \times (\text{SEQUENCE\_STAGE\_NUM} + 1)$ ms	$13.824 \times (\text{SEQUENCE\_STAGE\_NUM} + 1)$ ms	$27.648 \times (\text{SEQUENCE\_STAGE\_NUM} + 1)$ ms
9	$7.68 \times (\text{SEQUENCE\_STAGE\_NUM} + 1)$ ms	$15.36 \times (\text{SEQUENCE\_STAGE\_NUM} + 1)$ ms	$30.72 \times (\text{SEQUENCE\_STAGE\_NUM} + 1)$ ms
10	$8.448 \times (\text{SEQUENCE\_STAGE\_NUM} + 1)$ ms	$16.896 \times (\text{SEQUENCE\_STAGE\_NUM} + 1)$ ms	$33.792 \times (\text{SEQUENCE\_STAGE\_NUM} + 1)$ ms
11	$9.216 \times (\text{SEQUENCE\_STAGE\_NUM} + 1)$ ms	$18.432 \times (\text{SEQUENCE\_STAGE\_NUM} + 1)$ ms	$36.864 \times (\text{SEQUENCE\_STAGE\_NUM} + 1)$ ms
12	$9.984 \times (\text{SEQUENCE\_STAGE\_NUM} + 1)$ ms	$19.968 \times (\text{SEQUENCE\_STAGE\_NUM} + 1)$ ms	$39.936 \times (\text{SEQUENCE\_STAGE\_NUM} + 1)$ ms
13	$10.752 \times (\text{SEQUENCE\_STAGE\_NUM} + 1)$ ms	$21.504 \times (\text{SEQUENCE\_STAGE\_NUM} + 1)$ ms	$43.008 \times (\text{SEQUENCE\_STAGE\_NUM} + 1)$ ms
14	$11.52 \times (\text{SEQUENCE\_STAGE\_NUM} + 1)$ ms	$23.04 \times (\text{SEQUENCE\_STAGE\_NUM} + 1)$ ms	$46.08 \times (\text{SEQUENCE\_STAGE\_NUM} + 1)$ ms
15	$12.288 \times (\text{SEQUENCE\_STAGE\_NUM} + 1)$ ms	$24.576 \times (\text{SEQUENCE\_STAGE\_NUM} + 1)$ ms	$49.152 \times (\text{SEQUENCE\_STAGE\_NUM} + 1)$ ms

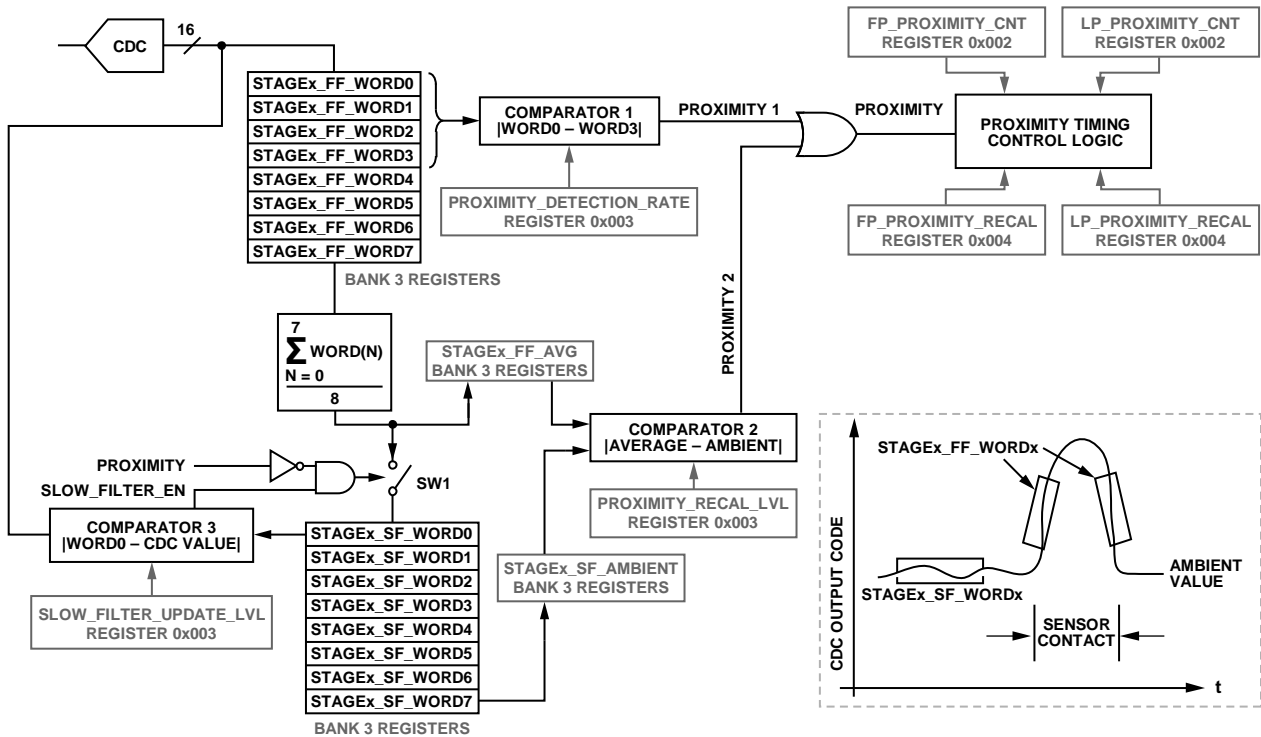

## NOTES

1. **SLOW\_FILTER\_EN**, WHICH IS THE NAME OF THE OUTPUT OF COMPARATOR 3, IS SET AND SW1 IS CLOSED WHEN  $|STAGEx\_SF\_WORD0 - CDC \text{ VALUE}|$  EXCEEDS THE VALUE PROGRAMMED IN THE **SLOW\_FILTER\_UPDATE\_LVL REGISTER** PROVIDING PROXIMITY IS NOT SET.
2. **PROXIMITY 1** IS SET WHEN  $|STAGEx\_FF\_WORD0 - STAGEx\_FF\_WORD3|$  EXCEEDS THE VALUE PROGRAMMED IN THE **PROXIMITY\_DETECTION\_RATE REGISTER**.
3. **PROXIMITY 2** IS SET WHEN  $|AVERAGE - AMBIENT|$  EXCEEDS THE VALUE PROGRAMMED IN THE **PROXIMITY\_RECAL\_LVL REGISTER**.
4. **DESCRIPTION OF COMPARATOR FUNCTIONS:**  
**COMPARATOR 1:** USED TO DETECT WHEN A USER IS APPROACHING OR LEAVING A SENSOR.  
**COMPARATOR 2:** USED TO DETECT WHEN A USER IS HOVERING OVER A SENSOR OR APPROACHING A SENSOR VERY SLOWLY. ALSO USED TO DETECT IF THE SENSOR AMBIENT LEVEL HAS CHANGED AS A RESULT OF THE USER INTERACTION. FOR EXAMPLE, HUMIDITY OR DIRT LEFT BEHIND ON SENSOR.  
**COMPARATOR 3:** USED TO ENABLE THE SLOW FILTER UPDATE RATE. THE SLOW FILTER IS UPDATED WHEN **SLOW\_FILTER\_EN** IS SET AND **PROXIMITY** IS NOT SET.

Figure 33. Proximity-Detection Logic



## ENVIRONMENTAL CALIBRATION

The AD7147A provides on-chip capacitance sensor calibration to automatically adjust for environmental conditions that have an effect on the ambient levels of the capacitance sensor. The output levels of the capacitance sensor are sensitive to temperature, humidity, and, in some cases, dirt.

The AD7147A achieves optimal and reliable sensor performance by continuously monitoring the CDC ambient levels and compensating for any environmental changes by adjusting the values of the `STAGEx_HIGH_THRESHOLD` registers and the `STAGEx_LOW_THRESHOLD` registers as described in the Threshold Equations section. The CDC ambient level is defined as the output level of the capacitance sensor during periods when the user is not approaching or in contact with the sensor.

After the AD7147A is configured, the compensation logic runs automatically with each conversion when the AD7147A is not being touched. This allows the AD7147A to compensate for rapidly changing environmental conditions.

The ambient compensation control registers provide the host with access to general setup and controls for the compensation algorithm. On-chip RAM stores the compensation data for each conversion stage, as well as setup information specific for each stage.

Figure 34 shows an example of the ideal behavior of a capacitance sensor, where the CDC ambient level remains constant regardless of the environmental conditions. The CDC output shown is for a pair of differential button sensors, where one sensor caused an increase and the other caused a decrease in measured capacitance when activated. The positive and negative sensor threshold levels are calculated as a percentage of the `STAGEx_OFFSET_HIGH` and `STAGEx_OFFSET_LOW` values, and are based on the threshold sensitivity settings and the ambient value. These values are sufficient to detect a sensor contact and result in the AD7147A asserting the `INT` output when the threshold levels are exceeded.

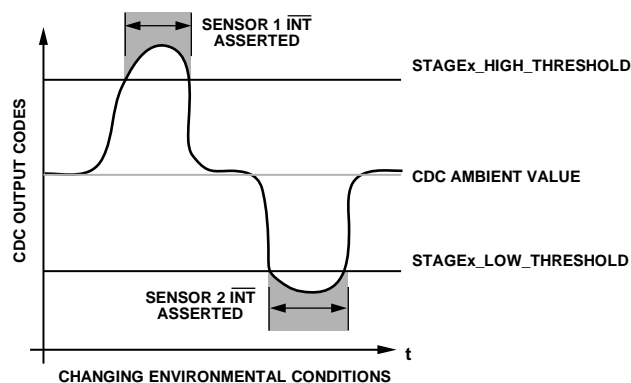

Figure 34. Ideal Sensor Behavior with a Constant Ambient Level

## CAPACITANCE SENSOR BEHAVIOR WITHOUT CALIBRATION

Figure 35 shows the typical behavior of a capacitance sensor when calibration is not applied and the ambient levels drifting over time as environmental conditions change. As a result of the initial threshold levels remaining constant while the ambient levels drift upward, Sensor 2 fails to detect a user contact in this example.

The Capacitance Sensor Behavior with Calibration section describes how the AD7147A adaptive calibration algorithm prevents such errors from occurring.

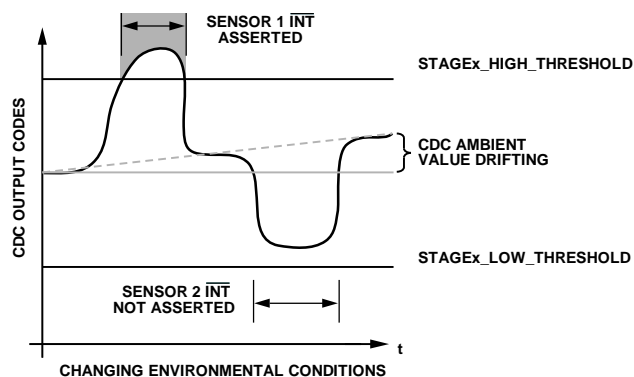

Figure 35. Typical Sensor Behavior Without Calibration

## THRESHOLD EQUATIONS

### On-Chip Logic Stage High Threshold

$$STAGEx\_HIGH\_THRESHOLD = STAGEx\_SF\_AMBIENT + \left( \frac{STAGEx\_OFFSET\_HIGH}{4} \right) + \left( \frac{\left( \frac{STAGEx\_OFFSET\_HIGH - STAGEx\_OFFSET\_HIGH}{4} \right)}{16} \right) \times POS\_THRESHOLD\_SENSITIVITY \quad (1)$$

### On-Chip Logic Stage Low Threshold

$$STAGEx\_LOW\_THRESHOLD = STAGEx\_SF\_AMBIENT + \left( \frac{STAGEx\_OFFSET\_LOW}{4} \right) + \left( \frac{\left( \frac{STAGEx\_OFFSET\_LOW - STAGEx\_OFFSET\_LOW}{4} \right)}{16} \right) \times NEG\_THRESHOLD\_SENSITIVITY \quad (2)$$

## CAPACITANCE SENSOR BEHAVIOR WITH CALIBRATION

The AD7147A on-chip adaptive calibration algorithm prevents sensor detection errors such as the one shown in Figure 35. This is achieved by monitoring the CDC ambient levels and readjusting the initial `STAGEx_OFFSET_HIGH` and `STAGEx_OFFSET_LOW` values according to the amount of ambient drift measured on each sensor. Based on the new stage offset values, the internal `STAGEx_HIGH_THRESHOLD` and `STAGEx_LOW_THRESHOLD` values described in Equation 1 and Equation 2 are automatically updated.

This closed-loop routine ensures the reliability and repeatable operation of every sensor connected to the AD7147A when they are subjected to dynamic environmental conditions. Figure 36 shows a simplified example of how the AD7147A applies the adaptive calibration process, resulting in no interrupt errors even with changing CDC ambient levels due to dynamic environmental conditions.

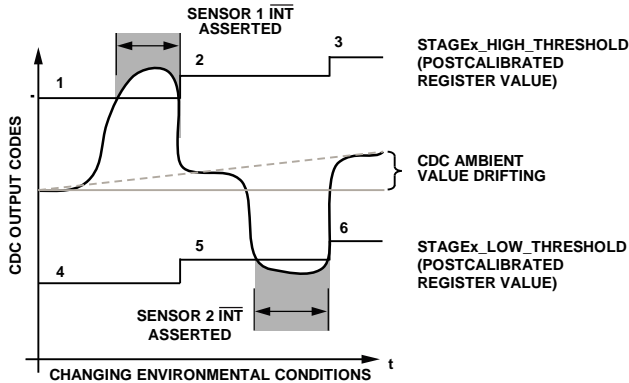

- 1 INITIAL `STAGEx_OFFSET_HIGH` REGISTER VALUE.
- 2 POSTCALIBRATED REGISTER `STAGEx_HIGH_THRESHOLD`.
- 3 POSTCALIBRATED REGISTER `STAGEx_HIGH_THRESHOLD`.
- 4 INITIAL `STAGEx_LOW_THRESHOLD`.
- 5 POSTCALIBRATED REGISTER `STAGEx_LOW_THRESHOLD`.
- 6 POSTCALIBRATED REGISTER `STAGEx_LOW_THRESHOLD`.

07727-036

Figure 36. Typical Sensor Behavior with Calibration Applied on the Data Path

## SLOW FIFO

As shown in Figure 33, there are a number of FIFOs implemented on the AD7147A. These FIFOs are located in Bank 3 of the on-chip memory. The slow FIFOs are used by the on-chip logic to monitor the ambient capacitance level from each sensor.

## AVG\_FP\_SKIP and AVG\_LP\_SKIP

In Register 0x001, Bits[13:12] are the slow FIFO skip control for full power mode, `AVG_FP_SKIP`. Bits[15:14] in the same register are the slow FIFO skip control for low power mode, `AVG_LP_SKIP`, and determine which CDC samples are not used (skipped) in the slow FIFO. Changing the values of the `AVG_FP_SKIP` and `AVG_LP_SKIP` bits slows down or speeds up the rate at which the ambient capacitance value tracks the measured capacitance value read by the converter.

- Slow FIFO update rate in full power mode =  $AVG\_FP\_SKIP \times [(3 \times \text{Decimation Rate}) \times (\text{SEQUENCE\_STAGE\_NUM} + 1) \times (\text{FF\_SKIP\_CNT} + 1) \times 4 \times 10^{-6}]$ .
- Slow FIFO update rate in low power mode =  $((AVG\_LP\_SKIP + 1) \times (3 \times \text{Decimation Rate}) \times (\text{SEQUENCE\_STAGE\_NUM} + 1) \times (4 \times 10^{-6})) + LP\_CONV\_DELAY$ .

The slow FIFO is used by the on-chip logic to track the ambient capacitance value. The slow FIFO expects to receive samples from the converter at a rate between 33 ms and 40 ms. `AVG_FP_SKIP` and `AVG_LP_SKIP` are used to normalize the frequency of the samples going into the FIFO, regardless of how many conversion stages are in a sequence.

Determining the `AVG_FP_SKIP` and `AVG_LP_SKIP` values is required only once during the initial setup of the capacitance sensor interface. The recommended values for these settings when using all 12 conversion stages on the AD7147A are as follows:

- `AVG_FP_SKIP = 00` = skip three samples
- `AVG_LP_SKIP = 00` = skip zero samples

## SLOW\_FILTER\_UPDATE\_LVL

`SLOW_FILTER_UPDATE_LVL` controls whether the most recent CDC measurement goes into the slow FIFO (slow filter). The slow filter is updated when the difference between the current CDC value and the last value of the slow FIFO is greater than the value of `SLOW_FILTER_UPDATE_LVL`, which is in the Ambient Control 1 register (`AMB_COMP_CTRL1`), Address 0x003.

## ADAPTIVE THRESHOLD AND SENSITIVITY

The AD7147A provides an on-chip, self-adjusting adaptive threshold and sensitivity algorithm. This algorithm continuously monitors the output levels of each sensor and automatically rescales the threshold levels in proportion to the sensor area covered by the user. As a result, the AD7147A maintains optimal threshold and sensitivity levels for all users regardless of their finger sizes.

The threshold level is always referenced from the ambient level and is defined as the CDC converter output level that must be exceeded before a valid sensor contact can occur. The sensitivity level is defined as how sensitive the sensor must be before a valid contact can be registered.

Figure 37 provides an example of how the adaptive threshold and sensitivity algorithm works. The positive and negative sensor threshold levels are calculated as a percentage of the `STAGEx_OFFSET_HIGH` and `STAGEx_OFFSET_LOW` values and are based on the threshold sensitivity settings and the ambient value. After the AD7147A is configured, initial estimates are supplied for both `STAGEx_OFFSET_HIGH` and `STAGEx_OFFSET_LOW`, and then the calibration engine automatically adjusts the `STAGEx_HIGH_THRESHOLD` and `STAGEx_LOW_THRESHOLD` values for sensor response.

The AD7147A tracks the average maximum and minimum values measured from each sensor. These values provide an indication of how the user is interacting with the sensor. A large

finger results in a large average maximum or minimum value, whereas a small finger results in smaller values. When the average maximum or minimum value changes, the threshold levels are rescaled to ensure that the threshold levels are appropriate for the current user. Figure 38 shows how the minimum and maximum sensor responses are tracked by the on-chip logic.

Reference A in Figure 37 shows a less sensitive threshold level for a user with small fingers and demonstrates the disadvantages of a fixed threshold level.

By enabling the adaptive threshold and sensitivity algorithm, the positive and negative threshold levels are determined by the `POS_THRESHOLD_SENSITIVITY` and `NEG_THRESHOLD_SENSITIVITY` bit values and by the most recent average maximum sensor output value. These bits can be used to select 16 different positive and negative sensitivity levels ranging between 25% and 95.32% of the most recent average maximum output level referenced from the ambient value. The smaller the sensitivity percentage setting, the easier it is to trigger a sensor activation. Reference B shows that the positive adaptive threshold level is set at almost midsensitivity with a 62.51% threshold level by setting `POS_THRESHOLD_SENSITIVITY = 1000`. Figure 37 also provides a similar example for the negative threshold level, with `NEG_THRESHOLD_SENSITIVITY = 0011`.

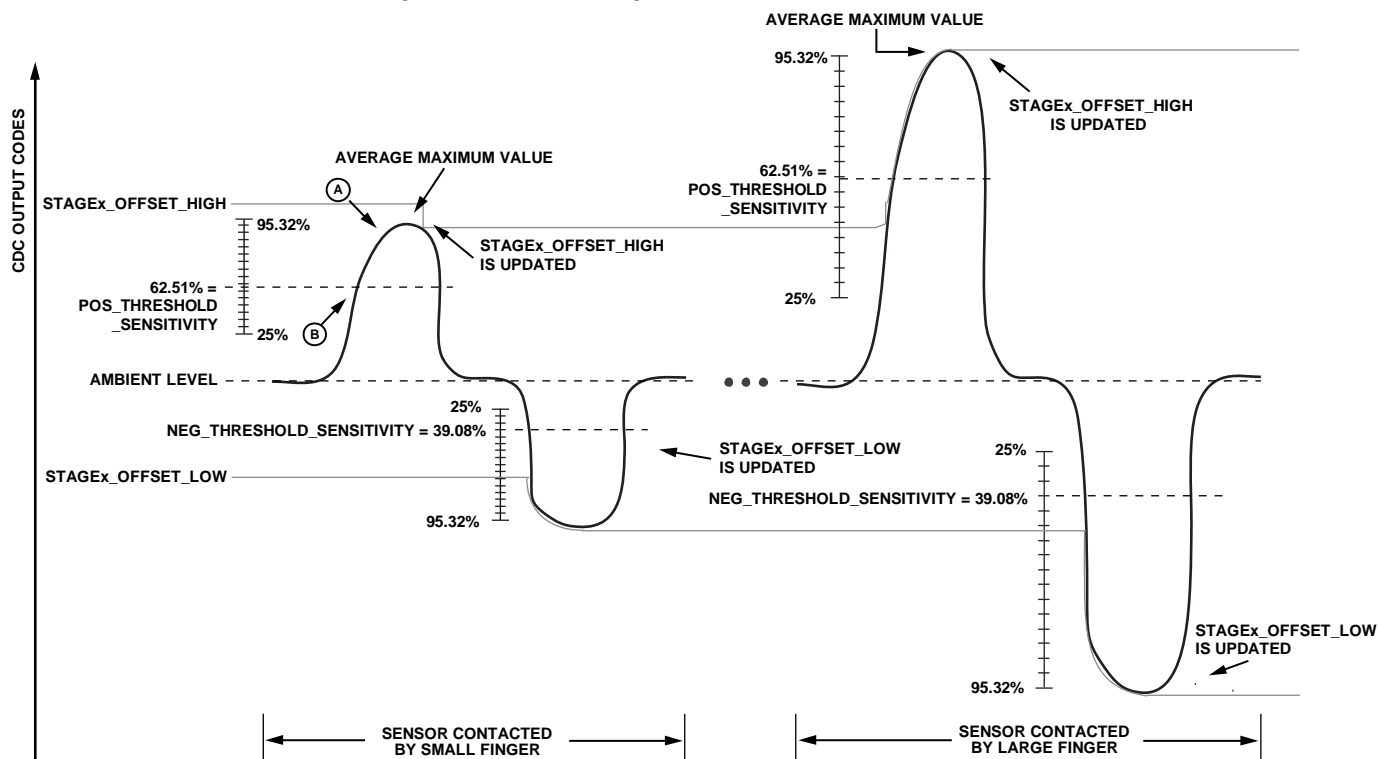

Figure 37. Example of Threshold Sensitivity (`POS_THRESHOLD_SENSITIVITY = 1000`, `NEG_THRESHOLD_SENSITIVITY = 0011`)

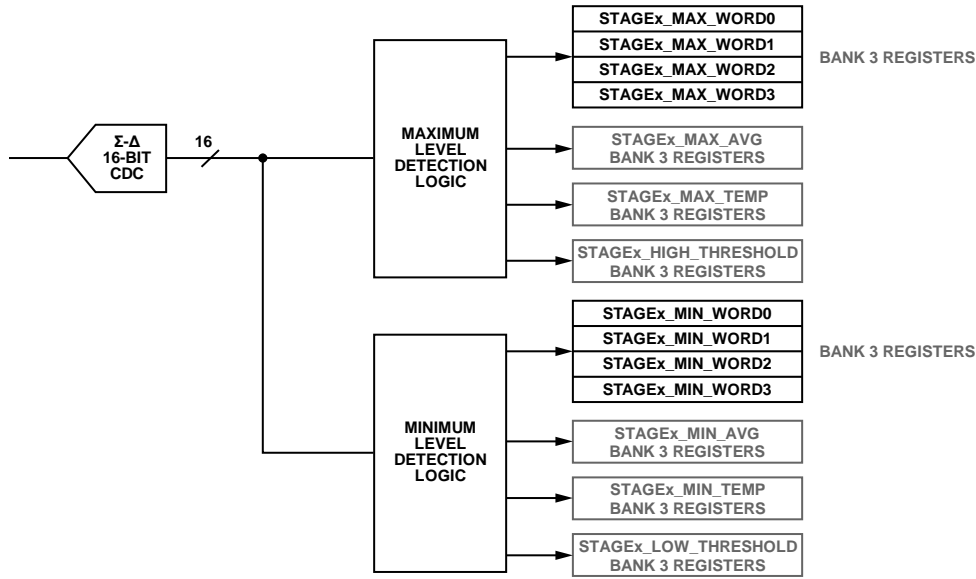

Figure 38. Tracking the Minimum and Maximum Average Sensor Values

Table 15. Additional Information About Environmental Calibration and Adaptive Threshold Registers

Register/Bit	Register Location	Description
NEG_THRESHOLD_SENSITIVITY	Bank 2	Used in Equation 2. This value is programmed once at startup.
NEG_PEAK_DETECT	Bank 2	Used by internal adaptive threshold logic only. The NEG_PEAK_DETECT is set to a percentage of the difference between the ambient CDC value and the minimum average CDC value. If the output of the CDC approaches the NEG_PEAK_DETECT percentage of the minimum average, the minimum average value is updated.
POS_THRESHOLD_SENSITIVITY	Bank 2	Used in Equation 1. This value is programmed once at startup.
POS_PEAK_DETECT	Bank 2	Used by internal adaptive threshold logic only. The POS_PEAK_DETECT is set to a percentage of the difference between the ambient CDC value and the maximum average CDC value. If the output of the CDC approaches the POS_PEAK_DETECT percentage of the maximum average, the maximum average value is updated.
STAGEx_OFFSET_LOW	Bank 2	Used in Equation 2. An initial value (based on sensor characterization) is programmed into this register at startup. The AD7147A on-chip calibration algorithm automatically updates this register based on the amount of sensor drift due to changing ambient conditions. Set this register to 80% of the STAGEx_OFFSET_LOW_CLAMP value.
STAGEx_OFFSET_HIGH	Bank 2	Used in Equation 1. An initial value (based on sensor characterization) is programmed into this register at startup. The AD7147A on-chip calibration algorithm automatically updates this register based on the amount of sensor drift due to changing ambient conditions. Set this register to 80% of the STAGEx_OFFSET_HIGH_CLAMP value.
STAGEx_OFFSET_HIGH_CLAMP	Bank 2	Used by internal environmental calibration and adaptive threshold algorithms only. An initial value (based on sensor characterization) is programmed into this register at startup. The value in this register prevents a user from causing the output value of a sensor to exceed the expected nominal value. Set this register to the maximum expected sensor response or the maximum change in CDC output code.
STAGEx_OFFSET_LOW_CLAMP	Bank 2	Used by internal environmental calibration and adaptive threshold algorithms only. An initial value (based on sensor characterization) is programmed into this register at startup. The value in this register prevents a user from causing the output value of a sensor to exceed the expected nominal value. Set this register to the minimum expected sensor response or the minimum change in CDC output code.
STAGEx_SF_AMBIENT	Bank 3	Used in Equation 1 and Equation 2. This is the ambient sensor output when the sensor is not touched, as calculated using the slow FIFO.
STAGEx_HIGH_THRESHOLD	Bank 3	Equation 1 value.
STAGEx_LOW_THRESHOLD	Bank 3	Equation 2 value.

## INTERRUPT OUTPUT

The AD7147A has an interrupt output that triggers an interrupt service routine on the host processor. The  $\overline{\text{INT}}$  signal is on Pin A1 and is an open-drain output. There are three types of interrupt events on the AD7147A: a CDC conversion-complete interrupt, a sensor-touch interrupt, and a GPIO interrupt. Each interrupt has enable and status registers. The conversion-complete and sensor-touch (sensor-activation) interrupts can be enabled on a per-conversion-stage basis. The status registers indicate what type of interrupt triggered the  $\overline{\text{INT}}$  pin. Status registers are cleared, and the  $\overline{\text{INT}}$  signal is reset high during a read operation. The signal returns high as soon as the read address has been set up.

### CDC CONVERSION-COMPLETE INTERRUPT

The AD7147A interrupt signal asserts low to indicate the completion of a conversion stage and that new conversion result data is available in the registers.

The interrupt can be independently enabled for each conversion stage. Each conversion-stage-complete interrupt can be enabled via the `STAGE_COMPLETE_INT_ENABLE` register (Address 0x007). This register has a bit that corresponds to each conversion stage. Setting this bit to 1 enables the interrupt for that stage. Clearing this bit to 0 disables the conversion-complete interrupt for that stage.

The AD7147A interrupt should be enabled only for the last stage in a conversion sequence. For example, if there are five conversion stages, only the conversion-complete interrupt for STAGE4 is enabled. Therefore,  $\overline{\text{INT}}$  asserts only when all five conversion stages are complete and the host can read new data from all five result registers. The interrupt is cleared by reading the `STAGE_COMPLETE_INT_STATUS` register located at Address 0x00A.

Register 0x00A is the conversion-complete interrupt status register. Each bit in this register corresponds to a conversion stage. If a bit is set, it means that the conversion-complete interrupt for the corresponding stage was triggered. This register is cleared upon a read if the underlying condition that triggered the interrupt is not present.

### SENSOR-TOUCH INTERRUPT

The sensor-touch interrupt mode is implemented when the host processor requires an interrupt only when a sensor is contacted.

Configuring the AD7147A into this mode results in the interrupt being asserted when the user makes contact with the sensor and again when the user stops touching the sensor. The second interrupt is required to alert the host processor that the user is no longer contacting the sensor.

The registers located at Address 0x005 and Address 0x006 are used to enable the interrupt output for each stage. The registers located at Address 0x008 and Address 0x009 are used to read back the interrupt status for each stage.

Figure 39 shows the interrupt output timing during contact with one of the sensors connected to STAGE0 while operating in the sensor-touch interrupt mode. For a low limit configuration, the interrupt output is asserted as soon as the sensor is contacted and again after the user has stopped touching the sensor. (Note that the interrupt output remains low until the host processor reads back the interrupt status registers located at Address 0x008 and Address 0x009.)

The interrupt output is asserted when there is a change in the interrupt status bits. This can indicate that a user is touching the sensor(s) for the first time, the number of sensors being touched has changed, or the user is no longer touching the sensor(s). Reading the status bits in the interrupt status register shows the current sensor activations.

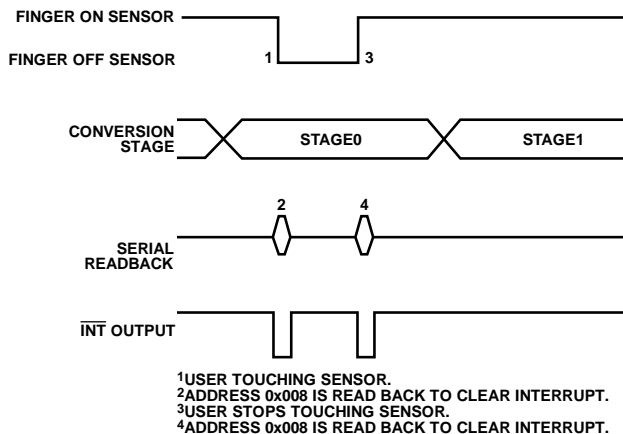
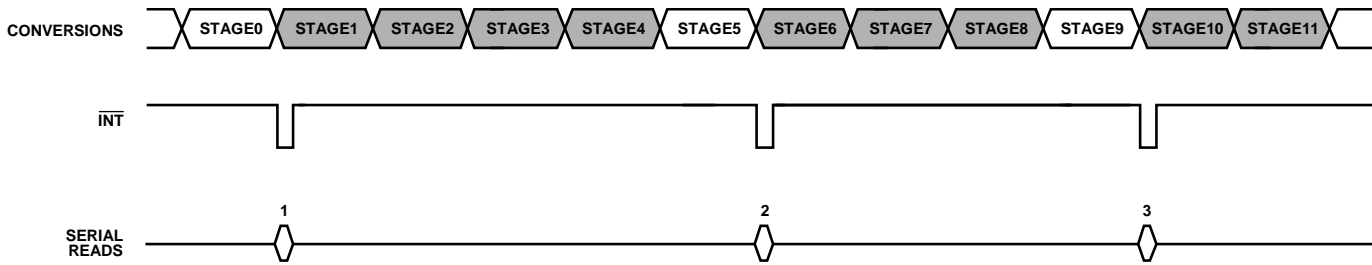

Figure 39. Example of Sensor-Touch Interrupt



**NOTES**

THIS IS AN EXAMPLE OF A CDC CONVERSION-COMPLETE INTERRUPT.

THIS TIMING EXAMPLE SHOWS THAT THE INTERRUPT OUTPUT HAS BEEN ASSERTED AT THE END OF A CONVERSION CYCLE FOR STAGE0, STAGE5, AND STAGE9. THE INTERRUPTS FOR ALL OTHER STAGES HAVE BEEN DISABLED.

STAGE<sub>x</sub> CONFIGURATION PROGRAMMING NOTES FOR STAGE0, STAGE5, AND STAGE9 (x = 0, 5, 9):

STAGE<sub>x</sub>\_LOW\_INT\_ENABLE (ADDRESS 0x005) = 0  
 STAGE<sub>x</sub>\_HIGH\_INT\_ENABLE (ADDRESS 0x006) = 0  
 STAGE<sub>x</sub>\_COMPLETE\_INT\_ENABLE (ADDRESS 0x007) = 1

STAGE<sub>x</sub> CONFIGURATION PROGRAMMING NOTES FOR STAGE1 THROUGH STAGE8, STAGE10, AND STAGE11 (x = 1, 2, 3, 4, 6, 7, 8, 10, 11):

STAGE<sub>x</sub>\_LOW\_INT\_ENABLE (ADDRESS 0x005) = 0  
 STAGE<sub>x</sub>\_HIGH\_INT\_ENABLE (ADDRESS 0x006) = 0  
 STAGE<sub>x</sub>\_COMPLETE\_INT\_ENABLE (ADDRESS 0x007) = 0

SERIAL READBACK REQUIREMENTS FOR STAGE0, STAGE5, AND STAGE9 (THIS READBACK OPERATION IS REQUIRED TO CLEAR THE INTERRUPT OUTPUT.):

- 1 READ THE STAGE0\_COMPLETE\_INT\_STATUS (ADDRESS 0x00A) BIT
- 2 READ THE STAGE5\_COMPLETE\_INT\_STATUS (ADDRESS 0x00A) BIT
- 3 READ THE STAGE9\_COMPLETE\_INT\_STATUS (ADDRESS 0x00A) BIT

Figure 40. Example of Configuring the Registers for Conversion-Complete Interrupt Setup

07727-040

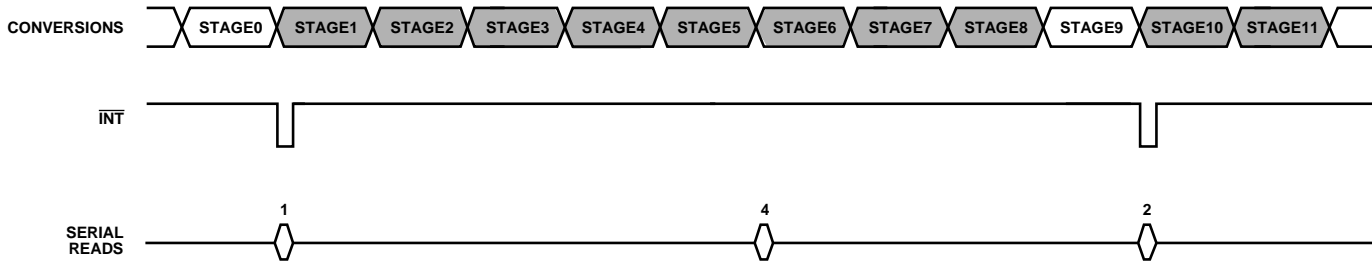

**NOTES**

THIS IS AN EXAMPLE OF A SENSOR-TOUCH INTERRUPT FOR A CASE WHERE THE LOW THRESHOLD LEVELS WERE EXCEEDED.

FOR EXAMPLE, THE SENSOR CONNECTED TO STAGE0 AND STAGE9 WERE CONTACTED, AND THE LOW THRESHOLD LEVELS WERE EXCEEDED, RESULTING IN THE INTERRUPT BEING ASSERTED. THE STAGE6 INTERRUPT WAS NOT ASSERTED BECAUSE THE USER DID NOT CONTACT THE SENSOR CONNECTED TO STAGE6.

STAGE<sub>x</sub> CONFIGURATION PROGRAMMING NOTES FOR STAGE0, STAGE6, AND STAGE9 (x = 0, 6, 9):

STAGE<sub>x</sub>\_LOW\_INT\_ENABLE (ADDRESS 0x005) = 1  
 STAGE<sub>x</sub>\_HIGH\_INT\_ENABLE (ADDRESS 0x006) = 0  
 STAGE<sub>x</sub>\_COMPLETE\_INT\_ENABLE (ADDRESS 0x007) = 0

STAGE<sub>x</sub> CONFIGURATION PROGRAMMING NOTES FOR STAGE1 THROUGH STAGE7, STAGE8, STAGE10, AND STAGE11 (x = 1, 2, 3, 4, 5, 7, 8, 10, 11):

STAGE<sub>x</sub>\_LOW\_INT\_ENABLE (ADDRESS 0x005) = 0  
 STAGE<sub>x</sub>\_HIGH\_INT\_ENABLE (ADDRESS 0x006) = 0  
 STAGE<sub>x</sub>\_COMPLETE\_INT\_ENABLE (ADDRESS 0x007) = 0

SERIAL READBACK REQUIREMENTS FOR STAGE0 AND STAGE9 (THIS READBACK OPERATION IS REQUIRED TO CLEAR THE INTERRUPT OUTPUT.):

- 1 READ THE STAGE0\_LOW\_INT\_STATUS (ADDRESS 0x008) BIT
- 2 READ THE STAGE5\_LOW\_INT\_STATUS (ADDRESS 0x008) BIT

Figure 41. Example of Configuring the Registers for Sensor-Touch Interrupt Setup

07727-041

## GPIO $\overline{\text{INT}}$ OUTPUT CONTROL

The  $\overline{\text{INT}}$  output signal can be controlled by the GPIO pin when the GPIO is configured as an input. The GPIO is configured as an input by setting the GPIO\_SETUP bits in the interrupt enable register to 01. See the General-Purpose Input/Output (GPIO) section for more information on how to configure the GPIO.

Enable the GPIO interrupt by setting the GPIO\_INT\_ENABLE bit in Register 0x007 to 1, or disable the GPIO interrupt by clearing this bit to 0. The GPIO status bit in the conversion-complete interrupt status register reflects the status of the GPIO

interrupt. This bit is set to 1 when the GPIO has triggered  $\overline{\text{INT}}$ . The bit is cleared upon reading the GPIO\_INT\_STATUS bit if the condition that caused the interrupt is no longer present.

The GPIO interrupt can be set to trigger on a rising edge, falling edge, high level, or low level at the GPIO input pin. Table 16 shows how the settings of the GPIO\_INPUT\_CONFIG bits in the interrupt enable (STAGE\_LOW\_INT\_ENABLE) register affect the behavior of  $\overline{\text{INT}}$ .

Figure 42 to Figure 45 show how the interrupt output is cleared upon a read from the GPIO\_INT\_STATUS bit.

**Table 16. GPIO Interrupt Behavior**

GPIO_INPUT_CONFIG	GPIO Pin	GPIO_INT_STATUS	$\overline{\text{INT}}$	$\overline{\text{INT}}$ Behavior
00 = Negative Level Triggered	1	0	1	Not triggered
00 = Negative Level Triggered	0	1	0	Asserted while signal on GPIO pin is low
01 = Positive Edge Triggered	1	1	0	Pulses low at low-to-high GPIO transition
01 = Positive Edge Triggered	0	0	1	Not triggered
10 = Negative Edge Triggered	1	0	1	Pulses low at high-to-low GPIO transition
10 = Negative Edge Triggered	0	1	0	Not triggered
11 = Positive Level Triggered	1	1	0	Asserted while signal on GPIO pin is high
11 = Positive Level Triggered	0	0	1	Not triggered

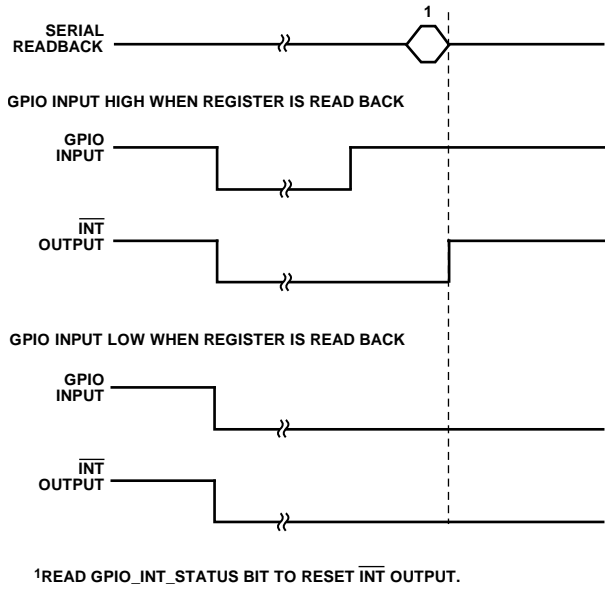

07727-042

Figure 42. Example of  $\overline{\text{INT}}$  Output Controlled by the GPIO Input  
(GPIO\_SETUP = 01, GPIO\_INPUT\_CONFIG = 00)

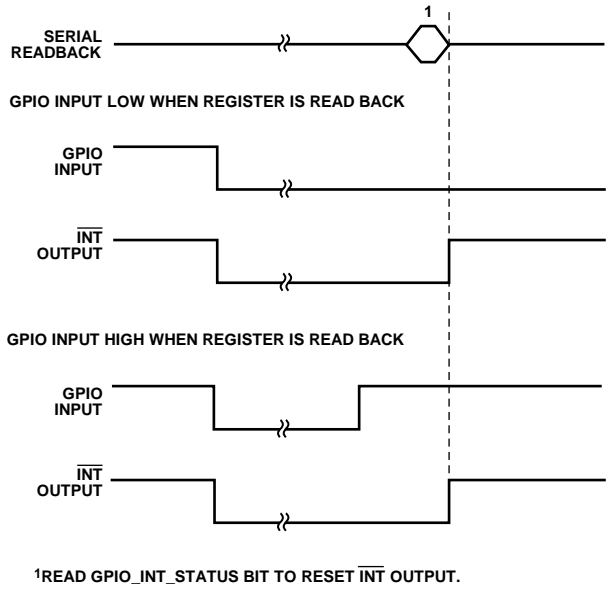

07727-044

Figure 44. Example of  $\overline{\text{INT}}$  Output Controlled by the GPIO Input  
(GPIO\_SETUP = 01, GPIO\_INPUT\_CONFIG = 10)

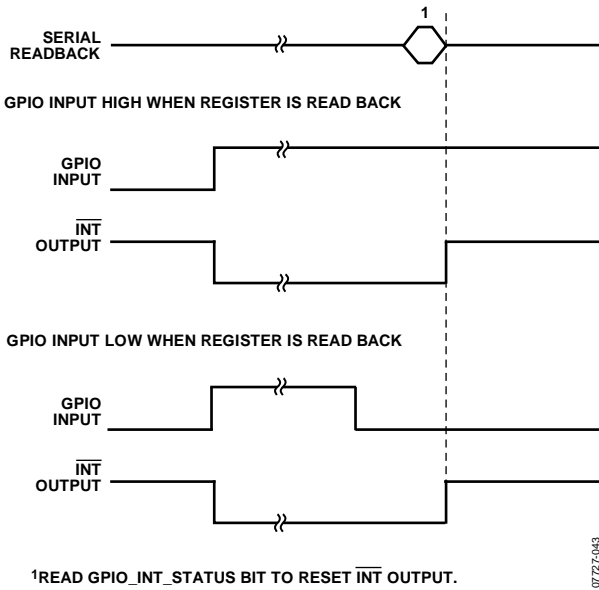

07727-043

Figure 43. Example of  $\overline{\text{INT}}$  Output Controlled by the GPIO Input  
(GPIO\_SETUP = 01, GPIO\_INPUT\_CONFIG = 01)

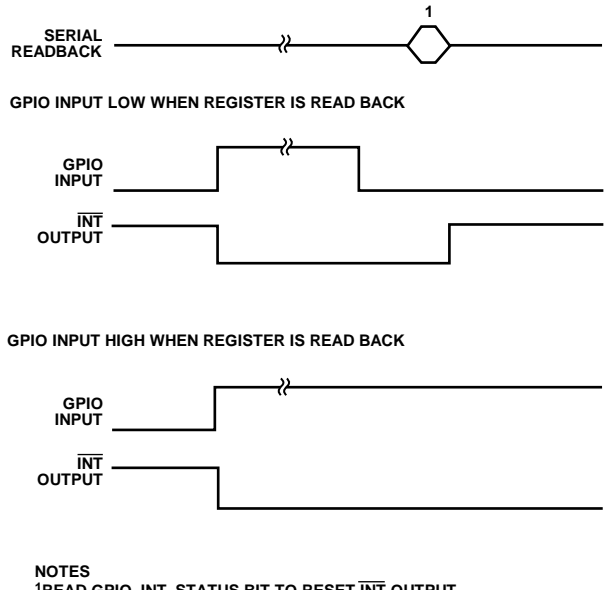

07727-045

Figure 45. Example of  $\overline{\text{INT}}$  Output Controlled by the GPIO Input  
(GPIO\_SETUP = 01, GPIO\_INPUT\_CONFIG = 11)



## OUTPUTS

### AC<sub>SHIELD</sub> OUTPUT

The AD7147A measures the capacitance between CIN<sub>x</sub> and ground. Any capacitance to ground on the signal path between the CIN<sub>x</sub> pins and the sensor is included in the AD7147A conversion result.

To eliminate stray capacitance to ground, the AC<sub>SHIELD</sub> signal should be used to shield the connection between the sensor and CIN<sub>x</sub>, as shown in Figure 46. The plane around the sensors should also be connected to AC<sub>SHIELD</sub>.

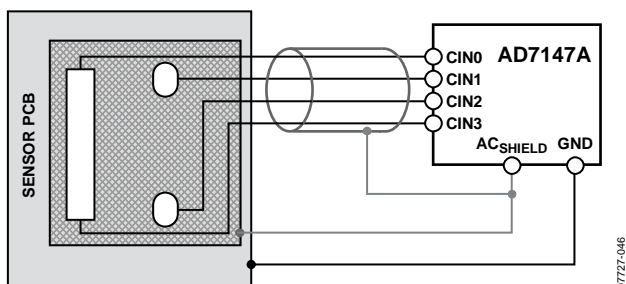

Figure 46. AC<sub>SHIELD</sub>

The AC<sub>SHIELD</sub> output is the same signal waveform as the excitation signal on CIN<sub>x</sub>. Therefore, there is no ac current between CIN<sub>x</sub> and AC<sub>SHIELD</sub>, and any capacitance between these pins does not affect the CIN<sub>x</sub> charge transfer.

Using AC<sub>SHIELD</sub> eliminates capacitance-to-ground pickup, which means that the AD7147A can be placed up to 10 cm away from the sensors. This allows the AD7147A to be placed on a separate PCB from that of the sensors if the connections between the sensors and the CIN<sub>x</sub> inputs are correctly shielded using AC<sub>SHIELD</sub>.

### GENERAL-PURPOSE INPUT/OUTPUT (GPIO)

The AD7147A has one GPIO pin. It can be configured as an input or an output. The GPIO\_SETUP Bits[13:12] in the STAGE\_LOW\_INT\_ENABLE register determine how the GPIO pin is configured.

Table 17. GPIO\_SETUP Bits

GPIO_SETUP	GPIO Configuration
00	GPIO disabled
01	Input
10	Output low
11	Output high

When the GPIO is configured as an output, the voltage level on the pin is set to either a low level or a high level, as defined by the GPIO\_SETUP bits (see Table 17).

The GPIO\_INPUT\_CONFIG bits in the STAGE\_LOW\_INT\_ENABLE register determine the response of the AD7147A to a signal on the GPIO pin when the GPIO is configured as an input. The GPIO can be configured as either active high or active low, as well as either edge triggered or level triggered (see Table 18).

Table 18. GPIO\_INPUT\_CONFIG Bits

GPIO_INPUT_CONFIG	GPIO Configuration
00	Triggered on negative level (active low)
01	Triggered on positive edge (active high)
10	Triggered on negative edge (active low)
11	Triggered on positive level (active high)

When GPIO is configured as an input, it triggers the interrupt output on the AD7147A.

Table 16 lists the interrupt output behavior for each of the GPIO configuration setups.

### USING THE GPIO TO TURN ON/OFF AN LED

The GPIO on the AD7147A can be used to turn an LED on and off by setting the GPIO as either output high or low. Setting the GPIO output high turns on the LED; setting the GPIO output low turns off the LED. The GPIO pin connects to a transistor that provides the drive current for the LED. Suitable transistors include the KTC3875 from Korea Electronics Co., Ltd. (KEC).

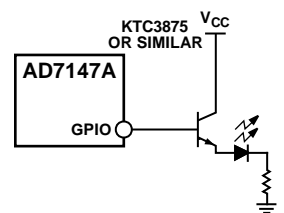

Figure 47. Controlling an LED Using the GPIO

## SERIAL INTERFACES

The AD7147A is available with an SPI interface. The AD7147A-1 is available with an I<sup>2</sup>C-compatible interface. Both parts are the same, with the exception of the serial interface.

### SPI INTERFACE

The AD7147A has a 4-wire serial peripheral interface (SPI). The SPI has a data input pin (SDI) for inputting data to the device, a data output pin (SDO) for reading data back from the device, and a data clock pin (SCLK) for clocking data into and out of the device. A chip select pin ( $\overline{CS}$ ) enables or disables the serial interface.  $\overline{CS}$  is required for correct operation of the SPI. Data is clocked out of the AD7147A on the negative edge of SCLK and data is clocked into the device on the positive edge of SCLK.

#### SPI Command Word

All data transactions on the SPI bus begin with the master taking  $\overline{CS}$  from high to low and sending out the command word. This indicates to the AD7147A whether the transaction is a read or a write and provides the address of the register from which to begin the data transfer. The following bit map shows the SPI command word.

MSB						LSB	
15	14	13	12	11	10	9:0	
1	1	1	0	0	R/W	Register address	

Bits[15:11] of the command word must be set to 11100 to successfully begin a bus transaction.

Bit 10 is the read/write bit; 1 indicates a read, and 0 indicates a write.

Bits[9:0] contain the target register address. When reading or writing to more than one register, this address indicates the address of the first register to be written to or read from.

#### Writing Data

Data is written to the AD7147A in 16-bit words. The first word written to the device is the command word, with the read/write bit set to 0. The master then supplies the 16-bit input data-word on the SDI line. The AD7147A clocks the data into the register addressed in the command word. If there is more than one word of data to be clocked in, the AD7147A automatically increments the address pointer and clocks the subsequent data-word into the next register.

The AD7147A continues to clock in data on the SDI line until either the master finishes the write transition by pulling  $\overline{CS}$  high or the address pointer reaches its maximum value. The AD7147A address pointer does not wrap around. When it reaches its maximum value, any data provided by the master on the SDI line is ignored by the AD7147A.

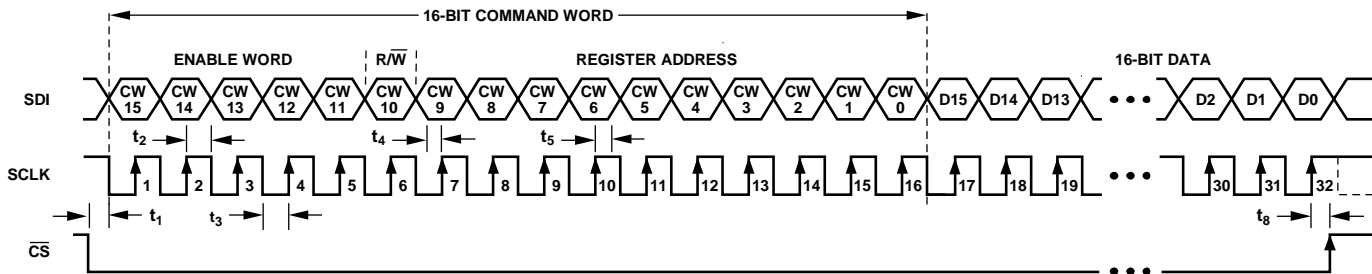

#### NOTES

- SDI BITS ARE LATCHED ON SCLK RISING EDGES. SCLK CAN IDLE HIGH OR LOW BETWEEN WRITE OPERATIONS.
- ALL 32 BITS MUST BE WRITTEN: 16 BITS FOR THE CONTROL WORD AND 16 BITS FOR THE DATA.
- 16-BIT COMMAND WORD SETTINGS FOR SERIAL WRITE OPERATION:  
 CW[15:11] = 11100 (ENABLE WORD)  
 CW[10] = 0 (R/W)  
 CW[9:0] = [AD9, AD8, AD7, AD6, AD5, AD4, AD3, AD2, AD1, AD0] (10-BIT MSB-JUSTIFIED REGISTER ADDRESS)

Figure 48. Single Register Write SPI Timing

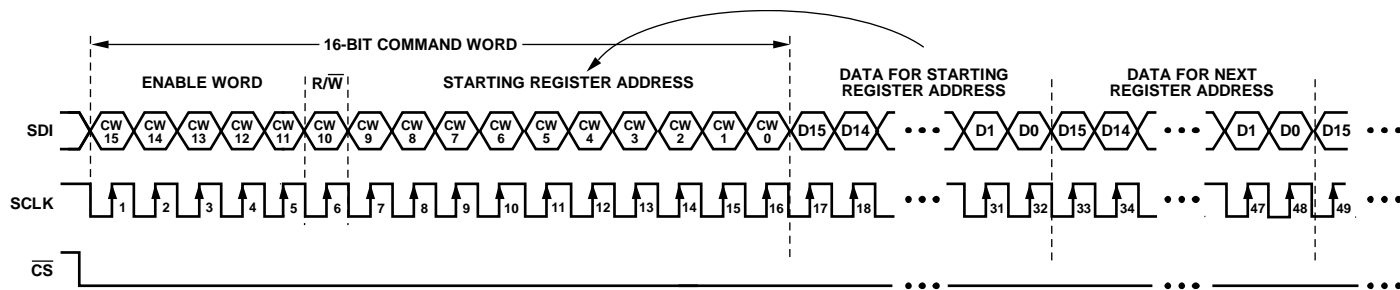

NOTES

1. MULTIPLE SEQUENTIAL REGISTERS CAN BE LOADED CONTINUOUSLY.
2. THE FIRST (LOWEST ADDRESS) REGISTER ADDRESS IS WRITTEN, FOLLOWED BY MULTIPLE 16-BIT DATA-WORDS.
3. THE ADDRESS AUTOMATICALLY INCREMENTS WITH EACH 16-BIT DATA-WORD (ALL 16 BITS MUST BE WRITTEN).
4. CS IS HELD LOW UNTIL THE LAST DESIRED REGISTER HAS BEEN LOADED.
5. 16-BIT COMMAND WORD SETTINGS FOR SEQUENTIAL WRITE OPERATION:  
 CW[15:11] = 11100 (ENABLE WORD)  
 CW[10] = 0 (R/W)  
 CW[9:0] = [AD9, AD8, AD7, AD6, AD5, AD4, AD3, AD2, AD1, AD0] (STARTING MSB-JUSTIFIED REGISTER ADDRESS)

Figure 49. Sequential Register Write SPI Timing

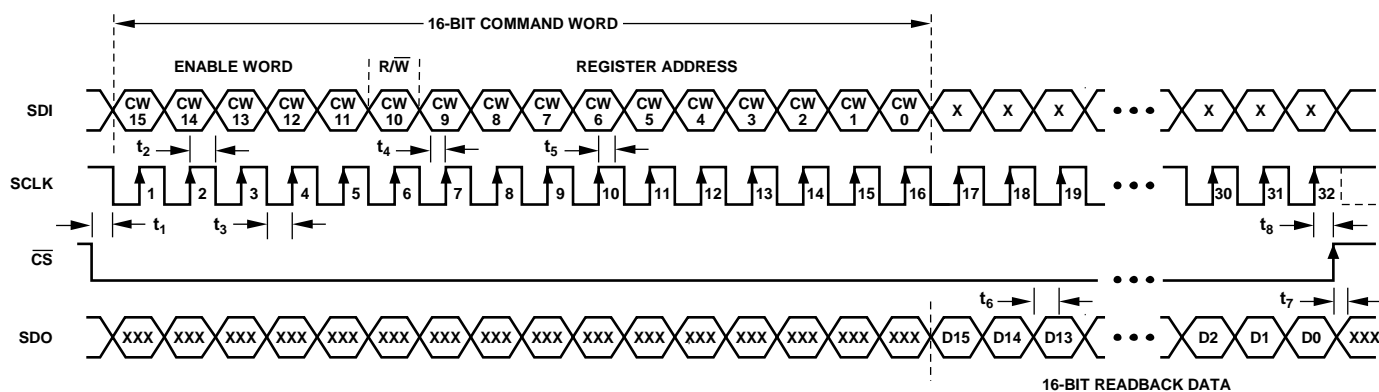

NOTES

1. SDI BITS ARE LATCHED ON SCLK RISING EDGES. SCLK CAN IDLE HIGH OR LOW BETWEEN WRITE OPERATIONS.
2. THE 16-BIT CONTROL WORD MUST BE WRITTEN ON SDI: 5 BITS FOR ENABLE WORD, 1 BIT FOR R/W, AND 10 BITS FOR REGISTER ADDRESS.
3. THE REGISTER DATA IS READ BACK ON THE SDO PIN.
4. X DENOTES DON'T CARE.
5. XXX DENOTES HIGH IMPEDANCE THREE-STATE OUTPUT.
6. CS IS HELD LOW UNTIL ALL REGISTER BITS HAVE BEEN READ BACK.
7. 16-BIT COMMAND WORD SETTINGS FOR SINGLE READBACK OPERATION:  
 CW[15:11] = 11100 (ENABLE WORD)  
 CW[10] = 1 (R/W)  
 CW[9:0] = [AD9, AD8, AD7, AD6, AD5, AD4, AD3, AD2, AD1, AD0] (10-BIT MSB-JUSTIFIED REGISTER ADDRESS)

Figure 50. Single Register Readback SPI Timing

**Reading Data**

A read transaction begins when the master writes the command word to the AD7147A with the read/write bit set to 1. The master then supplies 16 clock pulses per data-word to be read, and the AD7147A clocks out data from the addressed register on the SDO line. The first data-word is clocked out on the first falling edge of SCLK following the command word, as shown in Figure 50.

The AD7147A continues to clock out data on the SDO line if the master continues to supply the clock signal on SCLK. The read transaction finishes when the master takes CS high. If the AD7147A address pointer reaches its maximum value, the AD7147A repeatedly clocks out data from the addressed register. The address pointer does not wrap around.

# AD7147A

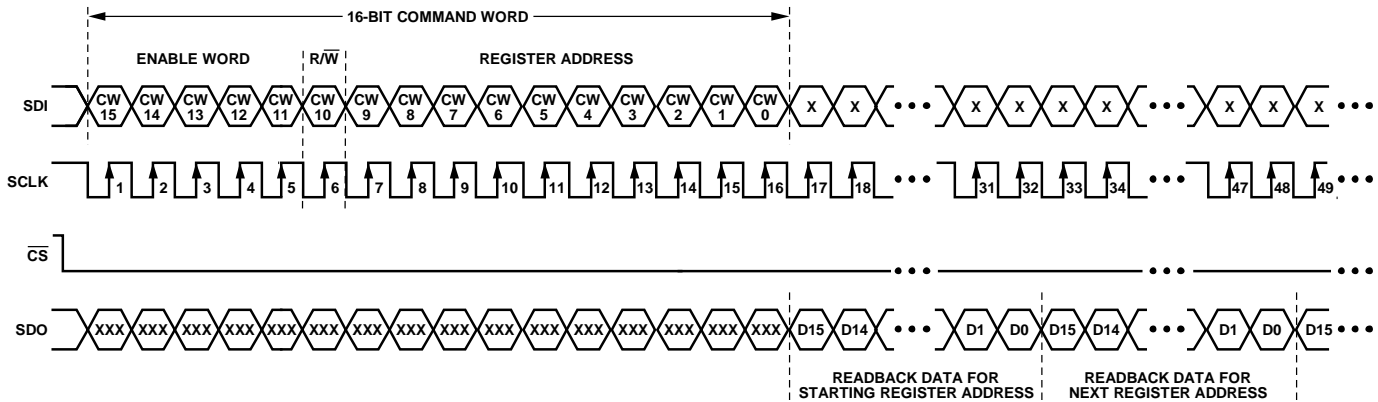

## NOTES

- MULTIPLE REGISTERS CAN BE READ BACK CONTINUOUSLY.
- THE 16-BIT CONTROL WORD MUST BE WRITTEN ON SDI: 5 BITS FOR ENABLE WORD, 1 BIT FOR  $\overline{R/\overline{W}}$ , AND 10 BITS FOR REGISTER ADDRESS.
- THE ADDRESS AUTOMATICALLY INCREMENTS WITH EACH 16-BIT DATA-WORD BEING READ BACK ON THE SDO PIN.
- $\overline{CS}$  IS HELD LOW UNTIL ALL REGISTER BITS HAVE BEEN READ BACK.
- X DENOTES DON'T CARE.
- XXX DENOTES HIGH IMPEDANCE THREE-STATE OUTPUT.
- 16-BIT COMMAND WORD SETTINGS FOR SEQUENTIAL READBACK OPERATION:  
 CW[15:11] = 11100 (ENABLE WORD)  
 CW[10] = 1 (R/W)  
 CW[9:0] = [AD9, AD8, AD7, AD6, AD5, AD4, AD3, AD2, AD1, AD0] (STARTING MSB-JUSTIFIED REGISTER ADDRESS)

Figure 51. Sequential Register Readback SPI Timing

07727-061

## I<sup>2</sup>C-COMPATIBLE INTERFACE

The AD7147A-1 supports the industry standard, 2-wire I<sup>2</sup>C serial interface protocol. The two wires associated with the I<sup>2</sup>C timing are the SCLK and SDA inputs. The SDA is an I/O pin that allows both register write and register readback operations. The AD7147A-1 is always a slave device on the I<sup>2</sup>C serial interface bus.

The AD7147A-1 has a 7-bit device address, Address 0101 1XX. The lower two bits are set by tying the ADD0 and ADD1 pins high or low. The AD7147A-1 responds when the master device sends its device address over the bus. The AD7147A-1 cannot initiate data transfers on the bus.

Table 19. AD7147A-1 I<sup>2</sup>C Device Address

ADD1	ADD0	I <sup>2</sup> C Address
0	0	0101 100
0	1	0101 101
1	0	0101 110
1	1	0101 111

## Data Transfer

Data is transferred over the I<sup>2</sup>C serial interface in 8-bit bytes. The master initiates a data transfer by establishing a start condition, defined as a high-to-low transition on the serial data line, SDA, while the serial clock line, SCLK, remains high. This indicates that an address/data stream follows.

All slave peripherals connected to the serial bus respond to the start condition and shift in the next eight bits, consisting of a 7-bit address (MSB first) plus an  $\overline{R/\overline{W}}$  bit that determines the direction of the data transfer. The peripheral whose address corresponds to the transmitted address responds by pulling the data line low during the ninth clock pulse. This is known as the acknowledge bit. All other devices on the bus then remain idle while the selected device waits for data to be read from or written to it. If the  $\overline{R/\overline{W}}$  bit is 0, the master writes to the slave device. If the  $\overline{R/\overline{W}}$  bit is 1, the master reads from the slave device.

Data is sent over the serial bus in a sequence of nine clock pulses—eight bits of data followed by an acknowledge bit from the slave device. Transitions on the data line must occur during the low period of the clock signal and remain stable during the high period, because a low-to-high transition when the clock is high can be interpreted as a stop signal. The number of data bytes transmitted over the serial bus in a single read or write operation is limited only by what the master and slave devices can handle.

When all data bytes are read or written, a stop condition is established. A stop condition is defined by a low-to-high transition on SDA while SCLK remains high. If the AD7147A encounters a stop condition, it returns to its idle condition, and the address pointer register resets to Address 0x00.

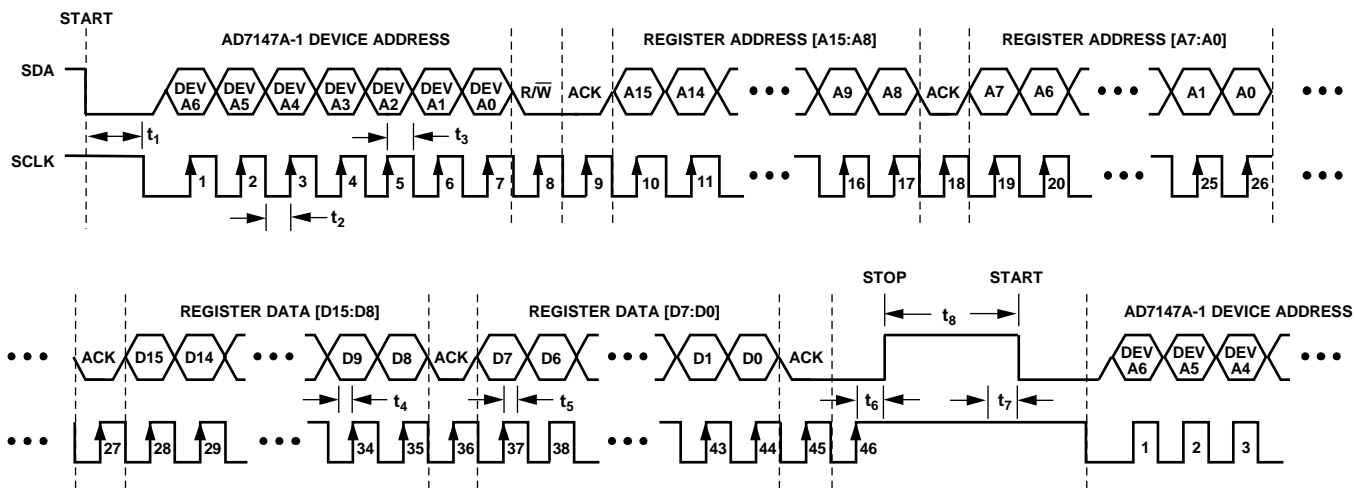

**NOTES**

1. A START CONDITION AT THE BEGINNING IS DEFINED AS A HIGH-TO-LOW TRANSITION ON SDA WHILE SCLK REMAINS HIGH.
2. A STOP CONDITION AT THE END IS DEFINED AS A LOW-TO-HIGH TRANSITION ON SDA WHILE SCLK REMAINS HIGH.
3. 7-BIT DEVICE ADDRESS [DEV A6:DEV A0] = [0 1 0 1 1 X X], WHERE X IS A DON'T CARE BIT.
4. 16-BIT REGISTER ADDRESS [A15:A0] = [X, X, X, X, X, X, X, X, A9, A8, A7, A6, A5, A4, A3, A2, A1, A0], WHERE X IS A DON'T CARE BIT.
5. REGISTER ADDRESS [A15:A8] AND REGISTER ADDRESS [A7:A0] ARE ALWAYS SEPARATED BY A LOW ACK BIT.
6. REGISTER DATA [D15:D8] AND REGISTER DATA [D7:D0] ARE ALWAYS SEPARATED BY A LOW ACK BIT.

Figure 52. Example of I<sup>2</sup>C Timing for Single Register Write Operation

01727-682

**Writing Data over the I<sup>2</sup>C Bus**

The process for writing to the AD7147A-1 over the I<sup>2</sup>C bus is shown in Figure 52 and Figure 54. The device address is sent over the bus, followed by the R/W bit being set to 0 and then two bytes of data that contain the 10-bit address of the internal data register to be written. The following bit map shows the upper register address bytes. Note that Bit 7 to Bit 2 in the upper address byte are don't care bits. The address is contained in the 10 LSBs of the register address bytes.

MSB							LSB	
7	6	5	4	3	2	1	0	
X	X	X	X	X	X	Register Address Bit 9	Register Address Bit 8	

The following bit map shows the lower register address bytes:

MSB							LSB	
7	6	5	4	3	2	1	0	
Reg Add Bit 7	Reg Add Bit 6	Reg Add Bit 5	Reg Add Bit 4	Reg Add Bit 3	Reg Add Bit 2	Reg Add Bit 1	Reg Add Bit 0	

The third data byte contains the eight MSBs of the data to be written to the internal register. The fourth data byte contains the eight LSBs of data to be written to the internal register.

The AD7147A-1 address pointer register automatically increments after each write. This allows the master to sequentially write to all registers on the AD7147A-1 in the same write transaction. However, the address pointer register does not

wrap around after the last address. Therefore, any data written to the AD7147A-1 after the address pointer has reached its maximum value is discarded.

All registers on the AD7147A-1 are 16 bits. Two consecutive 8-bit data bytes are combined and written to the 16-bit registers. To avoid errors, all writes to the device must contain an even number of data bytes.

To finish the transaction, the master generates a stop condition on SDO, or generates a repeat start condition if the master is to maintain control of the bus.

**Reading Data over the I<sup>2</sup>C Bus**

To read from the AD7147A-1, the address pointer register must first be set to the address of the required internal register. The master performs a write transaction and then writes to the AD7147A-1 to set the address pointer. Next, the master outputs a repeat start condition to keep control of the bus, or if this is not possible, ends the write transaction with a stop condition. A read transaction is initiated, with the R/W bit set to 1.

The AD7147A-1 supplies the upper eight bits of data from the addressed register in the first readback byte, followed by the lower eight bits in the next byte. This is shown in Figure 53 and Figure 54.

Because the address pointer automatically increments after each read, the AD7147A-1 continues to output readback data until the master sends a no acknowledge and stop condition to the bus. If the address pointer reaches its maximum value and the master continues to read from the part, the AD7147A-1 repeatedly sends data from the last register that was addressed.

# AD7147A

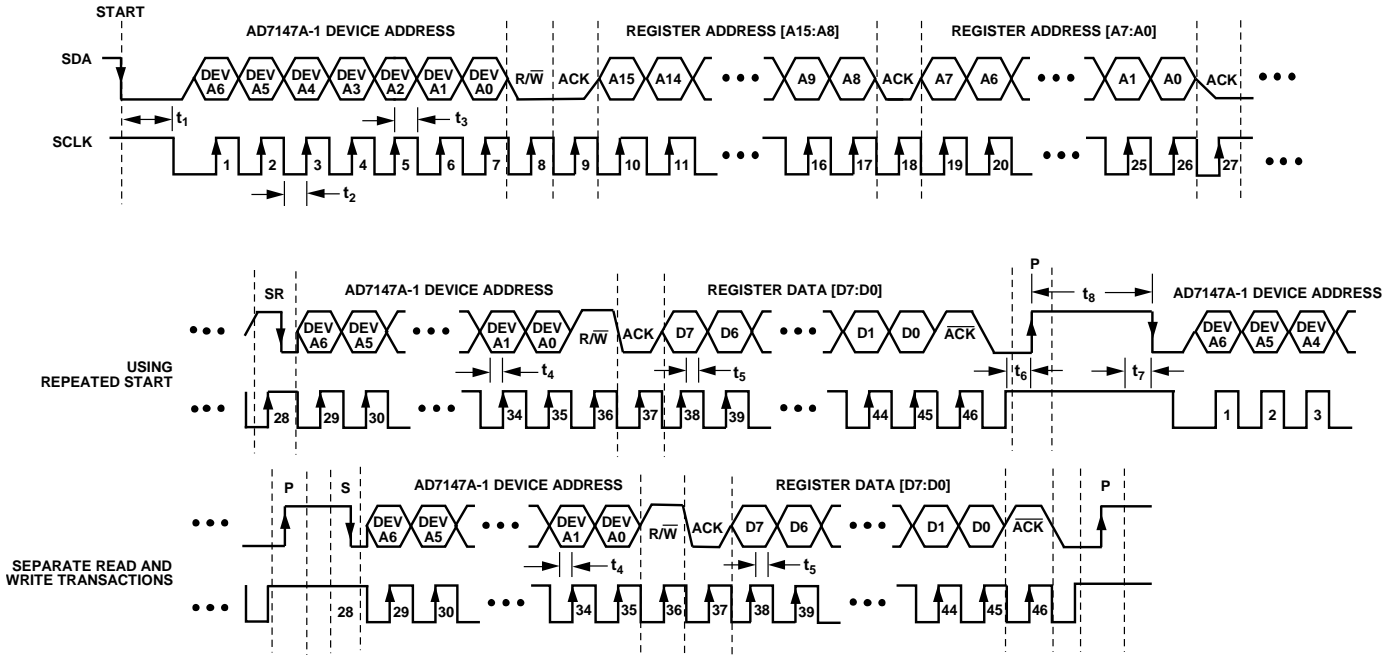

**NOTES**

1. A START CONDITION AT THE BEGINNING IS DEFINED AS A HIGH-TO-LOW TRANSITION ON SDA WHILE SCLK REMAINS HIGH.
2. A STOP CONDITION AT THE END IS DEFINED AS A LOW-TO-HIGH TRANSITION ON SDA WHILE SCLK REMAINS HIGH.
3. THE MASTER GENERATES THE ACK AT THE END OF THE READBACK TO SIGNAL THAT IT DOES NOT WANT ADDITIONAL DATA.
4. 7-BIT DEVICE ADDRESS [DEV A6:DEV A0] = [0 1 0 1 1 X X], WHERE THE TWO LSB Xs ARE DON'T CARE BITS.
5. 16-BIT REGISTER ADDRESS [A15:A0] = [X, X, X, X, X, X, X, A9, A8, A7, A6, A5, A4, A3, A2, A1, A0], WHERE THE UPPER LSB Xs ARE DON'T CARE BITS.
6. REGISTER ADDRESS [A15:A8] AND REGISTER ADDRESS [A7:A0] ARE ALWAYS SEPARATED BY LOW ACK BITS.
7. REGISTER DATA [D15:D8] AND REGISTER DATA [D7:D0] ARE ALWAYS SEPARATED BY A LOW ACK BIT.
8. THE R/W BIT IS SET TO A1 TO INDICATE A READBACK OPERATION.

Figure 53. Example of I<sup>2</sup>C Timing for Single Register Readback Operation

**WRITE**



**READ (USING REPEATED START)**

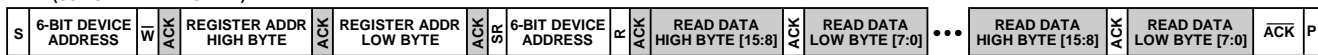

**READ (WRITE TRANSACTION SETS UP REGISTER ADDRESS)**

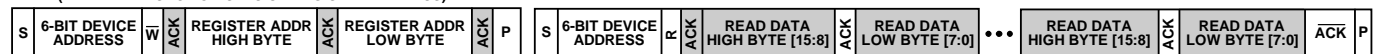

- |                          |                      |                          |                         |                          |                          |
|--------------------------|----------------------|--------------------------|-------------------------|--------------------------|--------------------------|
| <input type="checkbox"/> | OUTPUT FROM MASTER   | <input type="checkbox"/> | S = START BIT           | <input type="checkbox"/> | ACK = ACKNOWLEDGE BIT    |
| <input type="checkbox"/> | OUTPUT FROM AD7147-1 | <input type="checkbox"/> | P = STOP BIT            | <input type="checkbox"/> | ACK = NO ACKNOWLEDGE BIT |
| <input type="checkbox"/> |                      | <input type="checkbox"/> | SR = REPEATED START BIT |                          |                          |

Figure 54. Example of Sequential I<sup>2</sup>C Write and Readback Operations

## V<sub>DRIVE</sub> INPUT

The supply voltage for the pins (SDO, SDI, SCLK, SDA,  $\overline{CS}$ , INT, and GPIO) associated with both the I<sup>2</sup>C and SPI serial interfaces is supplied from the V<sub>DRIVE</sub> pin and is separate from the main V<sub>CC</sub> supply.

This allows the AD7147A to be connected directly to processors whose supply voltage is less than the minimum operating voltage of the AD7147A without the need for external level-shifters. The V<sub>DRIVE</sub> pin can be connected to voltage supplies as low as 1.65 V and as high as V<sub>CC</sub>.

## PCB DESIGN GUIDELINES

### CAPACITIVE SENSOR BOARD MECHANICAL SPECIFICATIONS

Table 20.

Parameter	Symbol	Min	Typ	Max	Unit
Distance from Edge of Any Sensor to Edge of Grounded Metal Object	$D_1$	0.1			mm
Distance Between Sensor Edges <sup>1</sup>	$D_2 = D_3 = D_4$	0			mm
Distance Between Bottom of Sensor Board and Controller Board or Grounded Metal Casing <sup>2</sup>	$D_5$		1.0		mm

<sup>1</sup> The distance is dependent on the application and the position of the switches relative to each other and with respect to the user's finger position and handling. Adjacent sensors with no space between them are implemented differentially.

<sup>2</sup> The 1.0 mm specification is intended to prevent direct sensor board contact with any conductive material. This specification, however, does not guarantee an absence of EMI coupling from the controller board to the sensors. To avoid potential EMI-coupling issues, place a grounded metal shield between the capacitive sensor board and the main controller board, as shown in Figure 57.

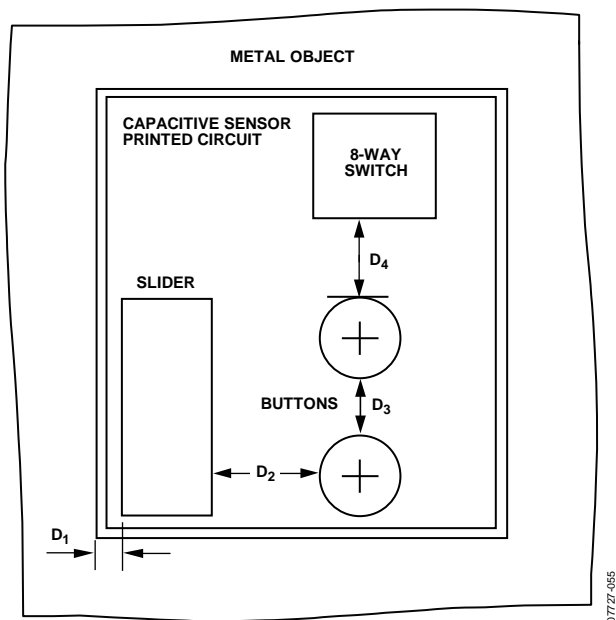

Figure 55. Capacitive Sensor Board, Top View

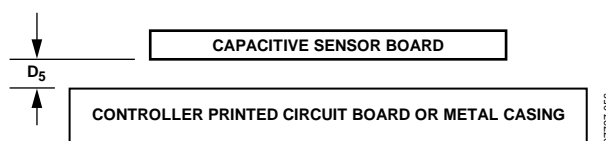

Figure 56. Capacitive Sensor Board, Side View

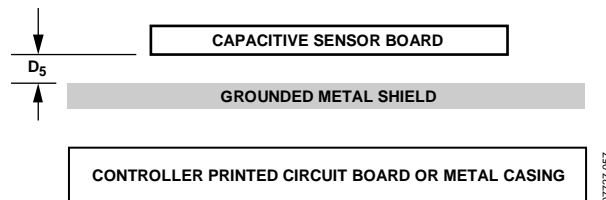

Figure 57. Capacitive Sensor Board with Grounded Shield

### WLCSP PACKAGE

Nonsolder mask definer PCB fabrication is recommended to increase the reliability of the solder joint.

The copper pad on the user's PCB should be 80% of the diameter of the WLCSP ball. The solder mask opening should be 50  $\mu\text{m}$  on either side of the copper pad.

See the AN-617 Application Note, *MicroCSP™ Wafer Level Chip Scale Package*, for more information and layout guidelines for the WLCSP package.

## POWER-UP SEQUENCE

To power up the AD7147A, use the following sequence when initially developing the AD7147A and microprocessor serial interface:

1. Turn on the power supplies to the AD7147A.
2. Write to the Bank 2 registers at Address 0x080 through Address 0x0DF. These registers are contiguous; therefore, a sequential register write sequence can be applied. Note that the Bank 2 register values are unique for each application. Register values come from characterization of the sensor in the application. The characterization process is outlined in the AN-929 Application Note, available from Analog Devices.
3. Write to the Bank 1 registers at Address 0x000 through Address 0x007, outlined as follows. These registers are contiguous; therefore, a sequential register write sequence can be applied (see Figure 49 and Figure 54).  
Caution: At this time, Address 0x001 must remain set to a default value of 0x0000 during this contiguous write operation.

Register values:

Address 0x000 = 0x82B2

Address 0x001 = 0x000

Address 0x002 = 0x3230 (depends on number of conversion stages used)

Address 0x003 = 0x419

Address 0x004 = 832

Address 0x005 = interrupt enable register (depends on required interrupt behavior)

Address 0x006 = interrupt enable register (depends on required interrupt behavior)

Address 0x007 = interrupt enable register (depends on required interrupt behavior)

4. Write to the Bank 1 register, Address 0x001 = 0x0FFF (depends on number of conversion stages used).
5. Read back the corresponding interrupt status register at Address 0x008, Address 0x009, or Address 0x00A. This is determined by the interrupt output configuration, as explained in the Interrupt Output section. Note that the specific registers required to be read back depend on each application. For buttons, the interrupt status registers are read back while other sensors read data back from the AD7147A according to the slider or wheel algorithm requirements. Analog Devices can provide this information after the user develops the sensor board.
6. Repeat Step 5 every time  $\overline{\text{INT}}$  is asserted.

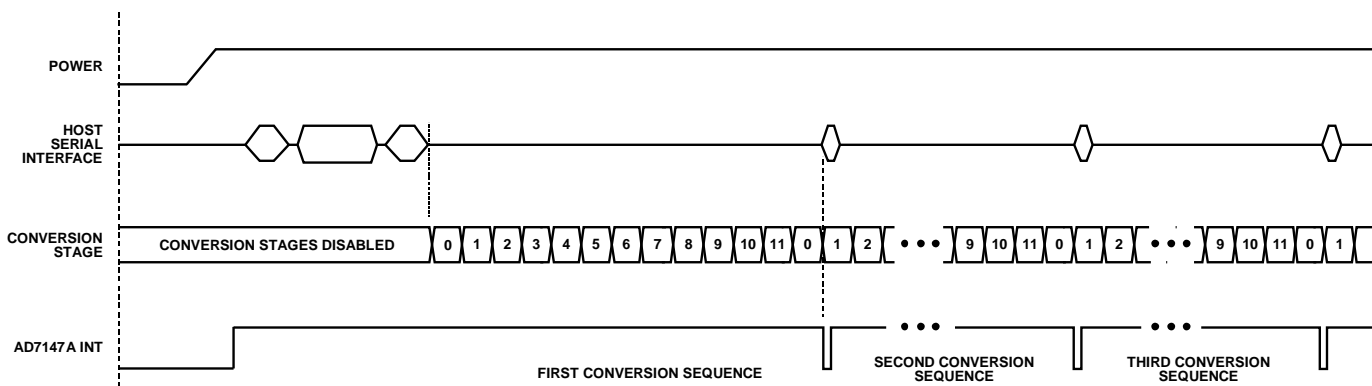

Figure 58. Recommended Start-Up Sequence

07727-508



# TYPICAL APPLICATION CIRCUITS

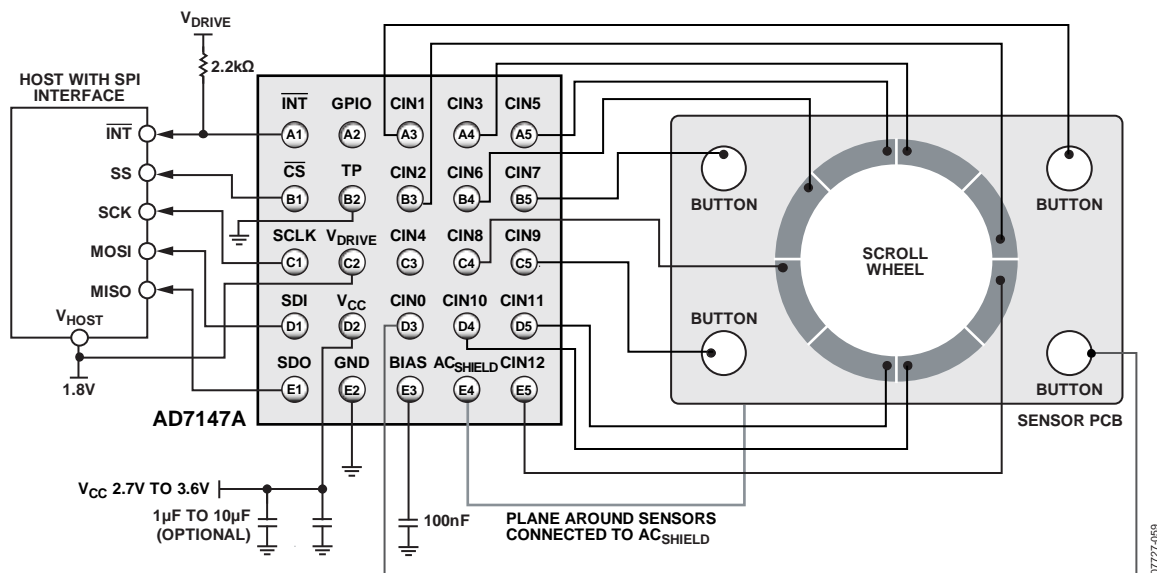

Figure 59. Typical Application Circuit with SPI Interface

07727-069

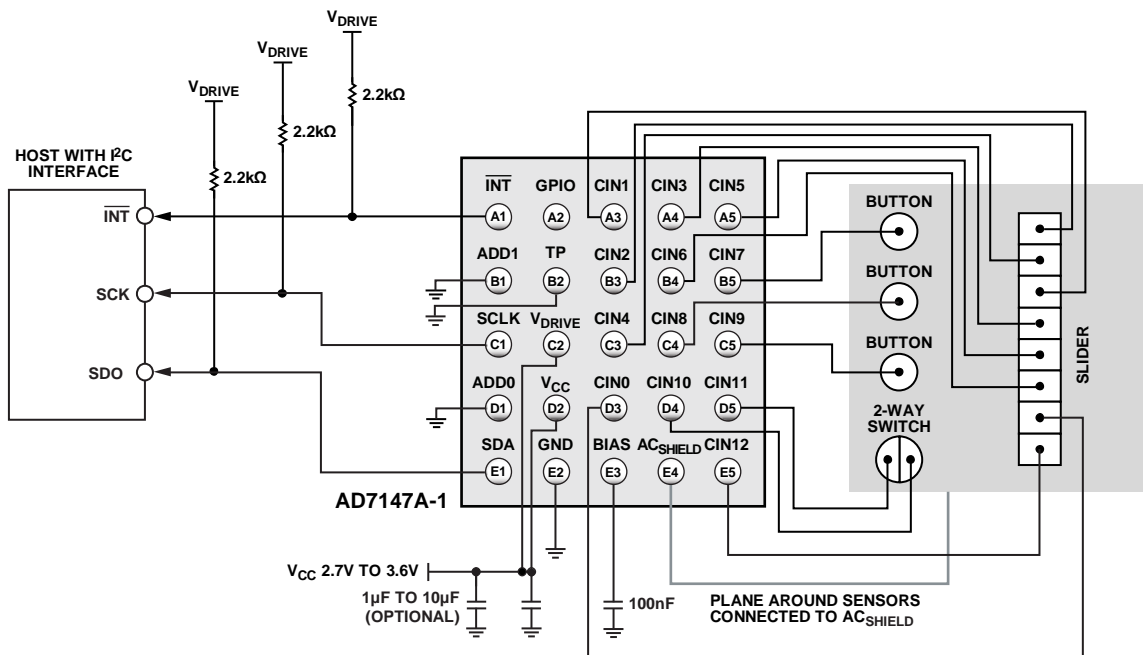

Figure 60. Typical Application Circuit with I2C Interface

07727-060

## REGISTER MAP

The AD7147A address space is divided into three register banks, referred to as Bank 1, Bank 2, and Bank 3. Figure 61 illustrates the division of these banks.

Bank 1 registers contain control registers, CDC conversion control registers, interrupt enable registers, interrupt status registers, CDC 16-bit conversion data registers, device ID registers, and proximity status registers.

Bank 2 registers contain the configuration registers used to configure the individual CINx inputs for each conversion stage. Initialize the Bank 2 configuration registers immediately after power-up to obtain valid CDC conversion result data.

Bank 3 registers contain the results of each conversion stage. These registers automatically update at the end of each conversion sequence. Although these registers are primarily used by the AD7147A internal data processing, they are accessible by the host processor for additional external data processing, if desired.

Default values are undefined for Bank 2 registers and Bank 3 registers until after power-up and configuration of the Bank 2 registers.

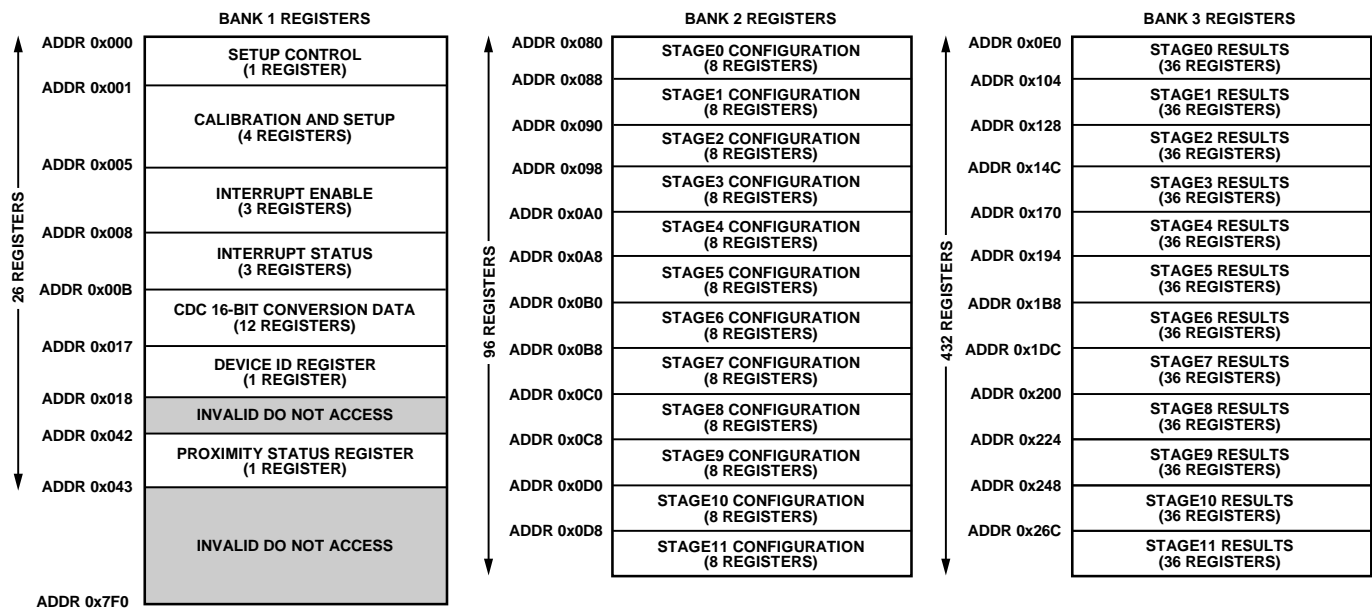

Figure 61. Layout of Bank 1, Bank 2, and Bank 3 Registers

0177Z-081

## DETAILED REGISTER DESCRIPTIONS

### BANK 1 REGISTERS

All addresses and default values are expressed in hexadecimal.

Table 21. PWR\_CONTROL Register

Address	Data Bit	Default Value	Type	Name	Description
0x000	[1:0]	0	R/W	POWER_MODE	Operating modes 00 = full power mode (normal operation, CDC conversions approximately every 36 ms) 01 = full shutdown mode (no CDC conversions) 10 = low power mode (automatic wake-up operation) 11 = full shutdown mode (no CDC conversions)
	[3:2]	0	R/W	LP_CONV_DELAY	Low power mode conversion delay 00 = 200 ms 01 = 400 ms 10 = 600 ms 11 = 800 ms
	[7:4]	0	R/W	SEQUENCE_STAGE_NUM	Number of stages in sequence (N + 1) 0000 = 1 conversion stage in sequence 0001 = 2 conversion stages in sequence ... Maximum value = 1011 = 12 conversion stages per sequence
	[9:8]	0	R/W	DECIMATION	ADC decimation factor 00 = decimate by 256 01 = decimate by 128 10 = decimate by 64 11 = decimate by 64
	[10]	0	R/W	SW_RESET	Software reset control (self-clearing) 1 = resets all registers to default values
	[11]	0	R/W	INT_POL	Interrupt polarity control 0 = active low 1 = active high
	[12]	0	R/W	EXT_SOURCE	Excitation source control 0 = enable excitation source to CINx pins 1 = disable excitation source to CINx pins
	[13]	0		Unused	Set to 0
	[15:14]	0	R/W	CDC_BIAS	CDC bias current control 00 = normal operation 01 = normal operation + 20% 10 = normal operation + 35% 11 = normal operation + 50%

**Table 22. STAGE\_CAL\_EN Register**

Address	Data Bit	Default Value	Type	Name	Description
0x001	[0]	0	R/W	STAGE0_CAL_EN	STAGE0 calibration enable 0 = disable 1 = enable
	[1]	0	R/W	STAGE1_CAL_EN	STAGE1 calibration enable 0 = disable 1 = enable
	[2]	0	R/W	STAGE2_CAL_EN	STAGE2 calibration enable 0 = disable 1 = enable
	[3]	0	R/W	STAGE3_CAL_EN	STAGE3 calibration enable 0 = disable 1 = enable
	[4]	0	R/W	STAGE4_CAL_EN	STAGE4 calibration enable 0 = disable 1 = enable
	[5]	0	R/W	STAGE5_CAL_EN	STAGE5 calibration enable 0 = disable 1 = enable
	[6]	0	R/W	STAGE6_CAL_EN	STAGE6 calibration enable 0 = disable 1 = enable
	[7]	0	R/W	STAGE7_CAL_EN	STAGE7 calibration enable 0 = disable 1 = enable
	[8]	0	R/W	STAGE8_CAL_EN	STAGE8 calibration enable 0 = disable 1 = enable
	[9]	0	R/W	STAGE9_CAL_EN	STAGE9 calibration enable 0 = disable 1 = enable
	[10]	0	R/W	STAGE10_CAL_EN	STAGE10 calibration enable 0 = disable 1 = enable
	[11]	0	R/W	STAGE11_CAL_EN	STAGE11 calibration enable 0 = disable 1 = enable
	[13:12]	0	R/W	AVG_FP_SKIP	Full power mode skip control 00 = skip three samples 01 = skip seven samples 10 = skip 15 samples 11 = skip 31 samples
	[15:14]	0	R/W	AVG_LP_SKIP	Low power mode skip control 00 = use all samples 01 = skip one sample 10 = skip two samples 11 = skip three samples

Table 23. AMB\_COMP\_CTRL0 Register

Address	Data Bit	Default Value	Type	Name	Description
0x002	[3:0]	0	R/W	FF_SKIP_CNT	Fast filter skip control (N + 1) 0000 = no sequence of results is skipped 0001 = one sequence of results is skipped for every one allowed into fast FIFO 0010 = two sequences of results are skipped for every one allowed into fast FIFO 1011 = maximum value = 12 sequences of results are skipped for every one allowed into fast FIFO
	[7:4]	F	R/W	FP_PROXIMITY_CNT	Calibration disable period in full power mode = FP_PROXIMITY_CNT × 16 × time for one conversion sequence in full power mode
	[11:8]	F	R/W	LP_PROXIMITY_CNT	Calibration disable period in low power mode = LP_PROXIMITY_CNT × 4 × time for one conversion sequence in low power mode
	[13:12]	0	R/W	PWR_DOWN_TIMEOUT	Full power to low power mode timeout control 00 = 1.25 × (FP_PROXIMITY_CNT) 01 = 1.50 × (FP_PROXIMITY_CNT) 10 = 1.75 × (FP_PROXIMITY_CNT) 11 = 2.00 × (FP_PROXIMITY_CNT)
	[14]	0	R/W	FORCED_CAL	Forced calibration control 0 = normal operation 1 = forces all conversion stages to recalibrate
	[15]	0	R/W	CONV_RESET	Conversion reset control (self-clearing) 0 = normal operation 1 = resets the conversion sequence to STAGE0

Table 24. AMB\_COMP\_CTRL1 Register

Address	Data Bit	Default Value	Type	Name	Description
0x003	[7:0]	64	R/W	PROXIMITY_RECAL_LVL	Proximity recalibration level. Value is multiplied by 16 to determine actual recalibration level.
	[13:8]	1	R/W	PROXIMITY_DETECTION_RATE	Proximity detection rate. Value is multiplied by 16 to determine actual detection rate.
	[15:14]	0	R/W	SLOW_FILTER_UPDATE_LVL	Slow filter update level.

Table 25. AMB\_COMP\_CTRL2 Register

Address	Data Bit	Default Value	Type	Name	Description
0x004	[9:0]	3FF	R/W	FP_PROXIMITY_RECAL	Full power mode proximity recalibration time control
	[15:10]	3F	R/W	LP_PROXIMITY_RECAL	Low power mode proximity recalibration time control

**Table 26. STAGE\_LOW\_INT\_ENABLE Register**

Address	Data Bit	Default Value	Type	Name	Description
0x005	[0]	0	R/W	STAGE0_LOW_INT_ENABLE	STAGE0 low interrupt enable 0 = interrupt source disabled 1 = $\overline{\text{INT}}$ asserted if STAGE0 low threshold is exceeded
	[1]	0	R/W	STAGE1_LOW_INT_ENABLE	STAGE1 low interrupt enable 0 = interrupt source disabled 1 = $\overline{\text{INT}}$ asserted if STAGE1 low threshold is exceeded
	[2]	0	R/W	STAGE2_LOW_INT_ENABLE	STAGE2 low interrupt enable 0 = interrupt source disabled 1 = $\overline{\text{INT}}$ asserted if STAGE2 low threshold is exceeded
	[3]	0	R/W	STAGE3_LOW_INT_ENABLE	STAGE3 low interrupt enable 0 = interrupt source disabled 1 = $\overline{\text{INT}}$ asserted if STAGE3 low threshold is exceeded
	[4]	0	R/W	STAGE4_LOW_INT_ENABLE	STAGE4 low interrupt enable 0 = interrupt source disabled 1 = $\overline{\text{INT}}$ asserted if STAGE4 low threshold is exceeded
	[5]	0	R/W	STAGE5_LOW_INT_ENABLE	STAGE5 low interrupt enable 0 = interrupt source disabled 1 = $\overline{\text{INT}}$ asserted if STAGE5 low threshold is exceeded
	[6]	0	R/W	STAGE6_LOW_INT_ENABLE	STAGE6 low interrupt enable 0 = interrupt source disabled 1 = $\overline{\text{INT}}$ asserted if STAGE6 low threshold is exceeded
	[7]	0	R/W	STAGE7_LOW_INT_ENABLE	STAGE7 low interrupt enable 0 = interrupt source disabled 1 = $\overline{\text{INT}}$ asserted if STAGE7 low threshold is exceeded
	[8]	0	R/W	STAGE8_LOW_INT_ENABLE	STAGE8 low interrupt enable 0 = interrupt source disabled 1 = $\overline{\text{INT}}$ asserted if STAGE8 low threshold is exceeded
	[9]	0	R/W	STAGE9_LOW_INT_ENABLE	STAGE9 low interrupt enable 0 = interrupt source disabled 1 = $\overline{\text{INT}}$ asserted if STAGE9 low threshold is exceeded
	[10]	0	R/W	STAGE10_LOW_INT_ENABLE	STAGE10 low interrupt enable 0 = interrupt source disabled 1 = $\overline{\text{INT}}$ asserted if STAGE10 low threshold is exceeded
	[11]	0	R/W	STAGE11_LOW_INT_ENABLE	STAGE11 low interrupt enable 0 = interrupt source disabled 1 = $\overline{\text{INT}}$ asserted if STAGE11 low threshold is exceeded
	[13:12]	0	R/W	GPIO_SETUP	GPIO setup 00 = disable GPIO pin 01 = configure GPIO as an input 10 = configure GPIO as an active low output 11 = configure GPIO as an active high output
	[15:14]	0	R/W	GPIO_INPUT_CONFIG	GPIO input configuration 00 = triggered on negative level 01 = triggered on positive edge 10 = triggered on negative edge 11 = triggered on positive level

Table 27. STAGE\_HIGH\_INT\_ENABLE Register

Address	Data Bit	Default Value	Type	Name	Description
0x006	[0]	0	R/W	STAGE0_HIGH_INT_ENABLE	STAGE0 high interrupt enable 0 = interrupt source disabled 1 = $\overline{\text{INT}}$ asserted if STAGE0 high threshold is exceeded
	[1]	0	R/W	STAGE1_HIGH_INT_ENABLE	STAGE1 high interrupt enable 0 = interrupt source disabled 1 = $\overline{\text{INT}}$ asserted if STAGE1 high threshold is exceeded
	[2]	0	R/W	STAGE2_HIGH_INT_ENABLE	STAGE2 high interrupt enable 0 = interrupt source disabled 1 = $\overline{\text{INT}}$ asserted if STAGE2 high threshold is exceeded
	[3]	0	R/W	STAGE3_HIGH_INT_ENABLE	STAGE3 high interrupt enable 0 = interrupt source disabled 1 = $\overline{\text{INT}}$ asserted if STAGE3 high threshold is exceeded
	[4]	0	R/W	STAGE4_HIGH_INT_ENABLE	STAGE4 high interrupt enable 0 = interrupt source disabled 1 = $\overline{\text{INT}}$ asserted if STAGE4 high threshold is exceeded
	[5]	0	R/W	STAGE5_HIGH_INT_ENABLE	STAGE5 high interrupt enable 0 = interrupt source disabled 1 = $\overline{\text{INT}}$ asserted if STAGE5 high threshold is exceeded
	[6]	0	R/W	STAGE6_HIGH_INT_ENABLE	STAGE6 high interrupt enable 0 = interrupt source disabled 1 = $\overline{\text{INT}}$ asserted if STAGE6 high threshold is exceeded
	[7]	0	R/W	STAGE7_HIGH_INT_ENABLE	STAGE7 high interrupt enable 0 = interrupt source disabled 1 = $\overline{\text{INT}}$ asserted if STAGE7 high threshold is exceeded
	[8]	0	R/W	STAGE8_HIGH_INT_ENABLE	STAGE8 high interrupt enable 0 = interrupt source disabled 1 = $\overline{\text{INT}}$ asserted if STAGE8 high threshold is exceeded
	[9]	0	R/W	STAGE9_HIGH_INT_ENABLE	STAGE9 high interrupt enable 0 = interrupt source disabled 1 = $\overline{\text{INT}}$ asserted if STAGE9 high threshold is exceeded
	[10]	0	R/W	STAGE10_HIGH_INT_ENABLE	STAGE10 high interrupt enable 0 = interrupt source disabled 1 = $\overline{\text{INT}}$ asserted if STAGE10 high threshold is exceeded
	[11]	0	R/W	STAGE11_HIGH_INT_ENABLE	STAGE11 high interrupt enable 0 = interrupt source disabled 1 = $\overline{\text{INT}}$ asserted if STAGE11 high threshold is exceeded
	[15:12]			Unused	Set to 0

**Table 28. STAGE\_COMPLETE\_INT\_ENABLE Register**

Address	Data Bit	Default Value	Type	Name	Description
0x007	[0]	0	R/W	STAGE0_COMPLETE_INT_ENABLE	STAGE0 conversion interrupt control 0 = interrupt source disabled 1 = $\overline{\text{INT}}$ asserted at completion of STAGE0 conversion
	[1]	0	R/W	STAGE1_COMPLETE_INT_ENABLE	STAGE1 conversion interrupt control 0 = interrupt source disabled 1 = $\overline{\text{INT}}$ asserted at completion of STAGE1 conversion
	[2]	0	R/W	STAGE2_COMPLETE_INT_ENABLE	STAGE2 conversion interrupt control 0 = interrupt source disabled 1 = $\overline{\text{INT}}$ asserted at completion of STAGE2 conversion
	[3]	0	R/W	STAGE3_COMPLETE_INT_ENABLE	STAGE3 conversion interrupt control 0 = interrupt source disabled 1 = $\overline{\text{INT}}$ asserted at completion of STAGE3 conversion
	[4]	0	R/W	STAGE4_COMPLETE_INT_ENABLE	STAGE4 conversion interrupt control 0 = interrupt source disabled 1 = $\overline{\text{INT}}$ asserted at completion of STAGE4 conversion
	[5]	0	R/W	STAGE5_COMPLETE_INT_ENABLE	STAGE5 conversion interrupt control 0 = interrupt source disabled 1 = $\overline{\text{INT}}$ asserted at completion of STAGE5 conversion
	[6]	0	R/W	STAGE6_COMPLETE_INT_ENABLE	STAGE6 conversion interrupt control 0 = interrupt source disabled 1 = $\overline{\text{INT}}$ asserted at completion of STAGE6 conversion
	[7]	0	R/W	STAGE7_COMPLETE_INT_ENABLE	STAGE7 conversion interrupt control 0 = interrupt source disabled 1 = $\overline{\text{INT}}$ asserted at completion of STAGE7 conversion
	[8]	0	R/W	STAGE8_COMPLETE_INT_ENABLE	STAGE8 conversion complete interrupt control 0 = interrupt source disabled 1 = $\overline{\text{INT}}$ asserted at completion of STAGE8 conversion
	[9]	0	R/W	STAGE9_COMPLETE_INT_ENABLE	STAGE9 conversion interrupt control 0 = interrupt source disabled 1 = $\overline{\text{INT}}$ asserted at completion of STAGE9 conversion
	[10]	0	R/W	STAGE10_COMPLETE_INT_ENABLE	STAGE10 conversion interrupt control 0 = interrupt source disabled 1 = $\overline{\text{INT}}$ asserted at completion of STAGE10 conversion
	[11]	0	R/W	STAGE11_COMPLETE_INT_ENABLE	STAGE11 conversion interrupt control 0 = interrupt source disabled 1 = $\overline{\text{INT}}$ asserted at completion of STAGE11 conversion
	[12]	0	R/W	GPIO_INT_ENABLE	Interrupt control when GPIO input pin changes level 0 = disabled 1 = enabled
[15:13]				Unused	Set to 0



Table 29. STAGE\_LOW\_INT\_STATUS Register<sup>1</sup>

Address	Data Bit	Default Value	Type	Name	Description
0x008	[0]	0	R	STAGE0_LOW_INT_STATUS	STAGE0 CDC conversion low limit interrupt result 1 = indicates STAGE0_LOW_THRESHOLD value was exceeded
	[1]	0	R	STAGE1_LOW_INT_STATUS	STAGE1 CDC conversion low limit interrupt result 1 = indicates STAGE1_LOW_THRESHOLD value was exceeded
	[2]	0	R	STAGE2_LOW_INT_STATUS	STAGE2 CDC conversion low limit interrupt result 1 = indicates STAGE2_LOW_THRESHOLD value was exceeded
	[3]	0	R	STAGE3_LOW_INT_STATUS	STAGE3 CDC conversion low limit interrupt result 1 = indicates STAGE3_LOW_THRESHOLD value was exceeded
	[4]	0	R	STAGE4_LOW_INT_STATUS	STAGE4 CDC conversion low limit interrupt result 1 = indicates STAGE4_LOW_THRESHOLD value was exceeded
	[5]	0	R	STAGE5_LOW_INT_STATUS	STAGE5 CDC conversion low limit interrupt result 1 = indicates STAGE5_LOW_THRESHOLD value was exceeded
	[6]	0	R	STAGE6_LOW_INT_STATUS	STAGE6 CDC conversion low limit interrupt result 1 = indicates STAGE6_LOW_THRESHOLD value was exceeded
	[7]	0	R	STAGE7_LOW_INT_STATUS	STAGE7 CDC conversion low limit interrupt result 1 = indicates STAGE7_LOW_THRESHOLD value was exceeded
	[8]	0	R	STAGE8_LOW_INT_STATUS	STAGE8 CDC conversion low limit interrupt result 1 = indicates STAGE8_LOW_THRESHOLD value was exceeded
	[9]	0	R	STAGE9_LOW_INT_STATUS	STAGE9 CDC conversion low limit interrupt result 1 = indicates STAGE9_LOW_THRESHOLD value was exceeded
	[10]	0	R	STAGE10_LOW_INT_STATUS	STAGE10 CDC conversion low limit interrupt result 1 = indicates STAGE10_LOW_THRESHOLD value was exceeded
	[11]	0	R	STAGE11_LOW_INT_STATUS	STAGE11 CDC conversion low limit interrupt result 1 = indicates STAGE11_LOW_THRESHOLD value was exceeded
[15:12]				Unused	Set to 0

<sup>1</sup> Registers self-clear to 0 after readback if the limits are not exceeded.

**Table 30. STAGE\_HIGH\_INT\_STATUS Register<sup>1</sup>**

Address	Data Bit	Default Value	Type	Name	Description
0x009	[0]	0	R	STAGE0_HIGH_INT_STATUS	STAGE0 CDC conversion high limit interrupt result 1 = indicates STAGE0_HIGH_THRESHOLD value was exceeded
	[1]	0	R	STAGE1_HIGH_INT_STATUS	STAGE1 CDC conversion high limit interrupt result 1 = indicates STAGE1_HIGH_THRESHOLD value was exceeded
	[2]	0	R	STAGE2_HIGH_INT_STATUS	STAGE2 CDC conversion high limit interrupt result 1 = indicates STAGE2_HIGH_THRESHOLD value was exceeded
	[3]	0	R	STAGE3_HIGH_INT_STATUS	STAGE3 CDC conversion high limit interrupt result 1 = indicates STAGE3_HIGH_THRESHOLD value was exceeded
	[4]	0	R	STAGE4_HIGH_INT_STATUS	STAGE4 CDC conversion high limit interrupt result 1 = indicates STAGE4_HIGH_THRESHOLD value was exceeded
	[5]	0	R	STAGE5_HIGH_INT_STATUS	STAGE5 CDC conversion high limit interrupt result 1 = indicates STAGE5_HIGH_THRESHOLD value was exceeded
	[6]	0	R	STAGE6_HIGH_INT_STATUS	STAGE6 CDC conversion high limit interrupt result 1 = indicates STAGE6_HIGH_THRESHOLD value was exceeded
	[7]	0	R	STAGE7_HIGH_INT_STATUS	STAGE7 CDC conversion high limit interrupt result 1 = indicates STAGE7_HIGH_THRESHOLD value was exceeded
	[8]	0	R	STAGE8_HIGH_INT_STATUS	STAGE8 CDC conversion high limit interrupt result 1 = indicates STAGE8_HIGH_THRESHOLD value was exceeded
	[9]	0	R	STAGE9_HIGH_INT_STATUS	STAGE9 CDC conversion high limit interrupt result 1 = indicates STAGE9_HIGH_THRESHOLD value was exceeded
	[10]	0	R	STAGE10_HIGH_INT_STATUS	STAGE10 CDC conversion high limit interrupt result 1 = indicates STAGE10_HIGH_THRESHOLD value was exceeded
	[11]	0	R	STAGE11_HIGH_INT_STATUS	STAGE11 CDC conversion high limit interrupt result 1 = indicates STAGE11_HIGH_THRESHOLD value was exceeded
	[15:12]			Unused	Set to 0

<sup>1</sup> Registers self-clear to 0 after readback if the limits are not exceeded.

Table 31. STAGE\_COMPLETE\_INT\_STATUS Register<sup>1</sup>

Address	Data Bit	Default Value	Type	Name	Description
0x00A	[0]	0	R	STAGE0_COMPLETE_INT_STATUS	STAGE0 conversion-complete register interrupt status 1 = indicates STAGE0 conversion completed
	[1]	0	R	STAGE1_COMPLETE_INT_STATUS	STAGE1 conversion-complete register interrupt status 1 = indicates STAGE1 conversion completed
	[2]	0	R	STAGE2_COMPLETE_INT_STATUS	STAGE2 conversion-complete register interrupt status 1 = indicates STAGE2 conversion completed
	[3]	0	R	STAGE3_COMPLETE_INT_STATUS	STAGE3 conversion-complete register interrupt status 1 = indicates STAGE3 conversion completed
	[4]	0	R	STAGE4_COMPLETE_INT_STATUS	STAGE4 conversion-complete register interrupt status 1 = indicates STAGE4 conversion completed
	[5]	0	R	STAGE5_COMPLETE_INT_STATUS	STAGE5 conversion-complete register interrupt status 1 = indicates STAGE5 conversion completed
	[6]	0	R	STAGE6_COMPLETE_INT_STATUS	STAGE6 conversion-complete register interrupt status 1 = indicates STAGE6 conversion completed
	[7]	0	R	STAGE7_COMPLETE_INT_STATUS	STAGE7 conversion-complete register interrupt status 1 = indicates STAGE7 conversion completed
	[8]	0	R	STAGE8_COMPLETE_INT_STATUS	STAGE8 conversion-complete register interrupt status 1 = indicates STAGE8 conversion completed
	[9]	0	R	STAGE9_COMPLETE_INT_STATUS	STAGE9 conversion-complete register interrupt status 1 = indicates STAGE9 conversion completed
	[10]	0	R	STAGE10_COMPLETE_INT_STATUS	STAGE10 conversion-complete register interrupt status 1 = indicates STAGE10 conversion completed
	[11]	0	R	STAGE11_COMPLETE_INT_STATUS	STAGE11 conversion-complete register interrupt status 1 = indicates STAGE11 conversion completed
	[12]	0	R	GPIO_INT_STATUS	GPIO input pin status 1 = indicates level on GPIO pin has changed
	[15:13]			Unused	Set to 0

<sup>1</sup> Registers self-clear to 0 after readback if the limits are not exceeded.

Table 32. CDC 16-Bit Conversion Data Registers

Address	Data Bit	Default Value	Type	Name	Description
0x00B	[15:0]	0	R	CDC_RESULT_S0	STAGE0 CDC 16-bit conversion data
0x00C	[15:0]	0	R	CDC_RESULT_S1	STAGE1 CDC 16-bit conversion data
0x00D	[15:0]	0	R	CDC_RESULT_S2	STAGE2 CDC 16-bit conversion data
0x00E	[15:0]	0	R	CDC_RESULT_S3	STAGE3 CDC 16-bit conversion data
0x00F	[15:0]	0	R	CDC_RESULT_S4	STAGE4 CDC 16-bit conversion data
0x010	[15:0]	0	R	CDC_RESULT_S5	STAGE5 CDC 16-bit conversion data
0x011	[15:0]	0	R	CDC_RESULT_S6	STAGE6 CDC 16-bit conversion data
0x012	[15:0]	0	R	CDC_RESULT_S7	STAGE7 CDC 16-bit conversion data
0x013	[15:0]	0	R	CDC_RESULT_S8	STAGE8 CDC 16-bit conversion data
0x014	[15:0]	0	R	CDC_RESULT_S9	STAGE9 CDC 16-bit conversion data
0x015	[15:0]	0	R	CDC_RESULT_S10	STAGE10 CDC 16-bit conversion data
0x016	[15:0]	0	R	CDC_RESULT_S11	STAGE11 CDC 16-bit conversion data

# AD7147A

Table 33. Device ID Register

Address	Data Bit	Default Value	Type	Name	Description
0x017	[3:0]	0	R	REVISION_CODE	Revision code
	[15:4]	147	R	DEVID	Device ID = 0001 0100 0111

Table 34. Proximity Status Register

Address	Data Bit	Default Value	Type	Name	Description
0x042	[0]	0	R	STAGE0_PROXIMITY_STATUS	STAGE0 proximity status register 1 = indicates proximity has been detected on STAGE0
	[1]	0	R	STAGE1_PROXIMITY_STATUS	STAGE1 proximity status register 1 = indicates proximity has been detected on STAGE1
	[2]	0	R	STAGE2_PROXIMITY_STATUS	STAGE2 proximity status register 1 = indicates proximity has been detected on STAGE2
	[3]	0	R	STAGE3_PROXIMITY_STATUS	STAGE3 proximity status register 1 = indicates proximity has been detected on STAGE3
	[4]	0	R	STAGE4_PROXIMITY_STATUS	STAGE4 proximity status register 1 = indicates proximity has been detected on STAGE4
	[5]	0	R	STAGE5_PROXIMITY_STATUS	STAGE5 proximity status register 1 = indicates proximity has been detected on STAGE5
	[6]	0	R	STAGE6_PROXIMITY_STATUS	STAGE6 proximity status register 1 = indicates proximity has been detected on STAGE6
	[7]	0	R	STAGE7_PROXIMITY_STATUS	STAGE7 proximity status register 1 = indicates proximity has been detected on STAGE7
	[8]	0	R	STAGE8_PROXIMITY_STATUS	STAGE8 proximity status register 1 = indicates proximity has been detected on STAGE8
	[9]	0	R	STAGE9_PROXIMITY_STATUS	STAGE9 proximity status register 1 = indicates proximity has been detected on STAGE9
	[10]	0	R	STAGE10_PROXIMITY_STATUS	STAGE10 proximity status register 1 = indicates proximity has been detected on STAGE10
	[11]	0	R	STAGE11_PROXIMITY_STATUS	STAGE11 proximity status register 1 = indicates proximity has been detected on STAGE11
	[15:12]			Unused	Set to 0

**BANK 2 REGISTERS**

All address values are expressed in hexadecimal.

**Table 35. STAGEx\_CONNECTION[6:0] Register Description (x = 0 to 11)**

Data Bit	Default Value <sup>1</sup>	Type	Name	Description
[1:0]	X	R/W	CIN0_CONNECTION_SETUP	CIN0 connection setup 00 = CIN0 not connected to CDC inputs 01 = CIN0 connected to CDC negative input 10 = CIN0 connected to CDC positive input 11 = CIN0 connected to BIAS (connect unused CINx inputs)
[3:2]	X	R/W	CIN1_CONNECTION_SETUP	CIN1 connection setup 00 = CIN1 not connected to CDC inputs 01 = CIN1 connected to CDC negative input 10 = CIN1 connected to CDC positive input 11 = CIN1 connected to BIAS (connect unused CINx inputs)
[5:4]	X	R/W	CIN2_CONNECTION_SETUP	CIN2 connection setup 00 = CIN2 not connected to CDC inputs 01 = CIN2 connected to CDC negative input 10 = CIN2 connected to CDC positive input 11 = CIN2 connected to BIAS (connect unused CINx inputs)
[7:6]	X	R/W	CIN3_CONNECTION_SETUP	CIN3 connection setup 00 = CIN3 not connected to CDC inputs 01 = CIN3 connected to CDC negative input 10 = CIN3 connected to CDC positive input 11 = CIN3 connected to BIAS (connect unused CINx inputs)
[9:8]	X	R/W	CIN4_CONNECTION_SETUP	CIN4 connection setup 00 = CIN4 not connected to CDC inputs 01 = CIN4 connected to CDC negative input 10 = CIN4 connected to CDC positive input 11 = CIN4 connected to BIAS (connect unused CINx inputs)
[11:10]	X	R/W	CIN5_CONNECTION_SETUP	CIN5 connection setup 00 = CIN5 not connected to CDC inputs 01 = CIN5 connected to CDC negative input 10 = CIN5 connected to CDC positive input 11 = CIN5 connected to BIAS (connect unused CINx inputs)
[13:12]	X	R/W	CIN6_CONNECTION_SETUP	CIN6 connection setup 00 = CIN6 not connected to CDC inputs 01 = CIN6 connected to CDC negative input 10 = CIN6 connected to CDC positive input 11 = CIN6 connected to BIAS (connect unused CINx inputs)
[15:14]	X		Unused	Set to 0

<sup>1</sup> X = don't care.

# AD7147A

**Table 36. STAGEx\_CONNECTION[12:7] Register Description (x = 0 to 11)**

Data Bit	Default Value <sup>1</sup>	Type	Name	Description
[1:0]	X	R/W	CIN7_CONNECTION_SETUP	CIN7 connection setup 00 = CIN7 not connected to CDC inputs 01 = CIN7 connected to CDC negative input 10 = CIN7 connected to CDC positive input 11 = CIN7 connected to BIAS (connect unused CINx inputs)
[3:2]	X	R/W	CIN8_CONNECTION_SETUP	CIN8 connection setup 00 = CIN8 not connected to CDC inputs 01 = CIN8 connected to CDC negative input 10 = CIN8 connected to CDC positive input 11 = CIN8 connected to BIAS (connect unused CINx inputs)
[5:4]	X	R/W	CIN9_CONNECTION_SETUP	CIN9 connection setup 00 = CIN9 not connected to CDC inputs 01 = CIN9 connected to CDC negative input 10 = CIN9 connected to CDC positive input 11 = CIN9 connected to BIAS (connect unused CINx inputs)
[7:6]	X	R/W	CIN10_CONNECTION_SETUP	CIN10 connection setup 00 = CIN10 not connected to CDC inputs 01 = CIN10 connected to CDC negative input 10 = CIN10 connected to CDC positive input 11 = CIN10 connected to BIAS (connect unused CINx inputs)
[9:8]	X	R/W	CIN11_CONNECTION_SETUP	CIN11 connection setup 00 = CIN11 not connected to CDC inputs 01 = CIN11 connected to CDC negative input 10 = CIN11 connected to CDC positive input 11 = CIN11 connected to BIAS (connect unused CINx inputs)
[11:10]	X	R/W	CIN12_CONNECTION_SETUP	CIN12 connection setup 00 = CIN12 not connected to CDC inputs 01 = CIN12 connected to CDC negative input 10 = CIN12 connected to CDC positive input 11 = CIN12 connected to BIAS (connect unused CINx inputs)
[13:12]	X	R/W	SE_CONNECTION_SETUP	Single-ended measurement connection setup 00 = Do not use 01 = Use when one CINx is connected to CDC positive input, single-ended measurements only 10 = Use when one CINx is connected to CDC negative input, single-ended measurements only 11 = Differential connection to CDC
[14]	X	R/W	NEG_AFE_OFFSET_DISABLE	Negative AFE offset enable control 0 = enable 1 = disable
[15]	X	R/W	POS_AFE_OFFSET_DISABLE	Positive AFE offset enable control 0 = enable 1 = disable

<sup>1</sup> X = don't care.

Table 37. STAGEx\_AFE\_OFFSET Register Description (x = 0 to 11)

Data Bit	Default Value <sup>1</sup>	Type	Name	Description
[5:0]	X	R/W	NEG_AFE_OFFSET	Negative AFE offset setting (20 pF range) 1 LSB value = 0.32 pF of offset
[6]	X		Unused	Set to 0
[7]	X	R/W	NEG_AFE_OFFSET_SWAP	Negative AFE offset swap control 0 = NEG_AFE_OFFSET applied to CDC negative input 1 = NEG_AFE_OFFSET applied to CDC positive input
[13:8]	X	R/W	POS_AFE_OFFSET	Positive AFE offset setting (20 pF range) 1 LSB value = 0.32 pF of offset
[14]	X		Unused	Set to 0
[15]	X	R/W	POS_AFE_OFFSET_SWAP	Positive AFE offset swap control 0 = POS_AFE_OFFSET applied to CDC positive input 1 = POS_AFE_OFFSET applied to CDC negative input

<sup>1</sup> X = don't care.

Table 38. STAGEx\_SENSITIVITY Register Description (x = 0 to 11)

Data Bit	Default Value <sup>1</sup>	Type	Name	Description
[3:0]	X	R/W	NEG_THRESHOLD_SENSITIVITY	Negative threshold sensitivity control 0000 = 25%, 0001 = 29.73%, 0010 = 34.40%, 0011 = 39.08% 0100 = 43.79%, 0101 = 48.47%, 0110 = 53.15% 0111 = 57.83%, 1000 = 62.51%, 1001 = 67.22% 1010 = 71.90%, 1011 = 76.58%, 1100 = 81.28% 1101 = 85.96%, 1110 = 90.64%, 1111 = 95.32%
[6:4]	X	R/W	NEG_PEAK_DETECT	Negative peak detect setting 000 = 40% level, 001 = 50% level, 010 = 60% level 011 = 70% level, 100 = 80% level, 101 = 90% level
[7]	X	R/W	Unused	Set to 0
[11:8]	X	R/W	POS_THRESHOLD_SENSITIVITY	Positive threshold sensitivity control 0000 = 25%, 0001 = 29.73%, 0010 = 34.40%, 0011 = 39.08% 0100 = 43.79%, 0101 = 48.47%, 0110 = 53.15% 0111 = 57.83%, 1000 = 62.51%, 1001 = 67.22% 1010 = 71.90%, 1011 = 76.58%, 1100 = 81.28% 1101 = 85.96%, 1110 = 90.64%, 1111 = 95.32%
[14:12]	X	R/W	POS_PEAK_DETECT	Positive peak detect setting 000 = 40% level, 001 = 50% level, 010 = 60% level 011 = 70% level, 100 = 80% level, 101 = 90% level
[15]	X	R/W	Unused	Set to 0

<sup>1</sup> X = don't care.

Table 39. STAGE0 to STAGE12 Configuration Registers

Address	Data Bit	Default <sup>1</sup>	Type	Name	Description
0x080	[15:0]	X	R/W	STAGE0_CONNECTION[6:0]	STAGE0 CIN[6:0] connection setup (see Table 35)
0x081	[15:0]	X	R/W	STAGE0_CONNECTION[12:7]	STAGE0 CIN[12:7] connection setup (see Table 36)
0x082	[15:0]	X	R/W	STAGE0_AFE_OFFSET	STAGE0 AFE offset control (see Table 37)
0x083	[15:0]	X	R/W	STAGE0_SENSITIVITY	STAGE0 sensitivity control (see Table 38)
0x084	[15:0]	X	R/W	STAGE0_OFFSET_LOW	STAGE0 initial offset low value
0x085	[15:0]	X	R/W	STAGE0_OFFSET_HIGH	STAGE0 initial offset high value
0x086	[15:0]	X	R/W	STAGE0_OFFSET_HIGH_CLAMP	STAGE0 offset high clamp value
0x087	[15:0]	X	R/W	STAGE0_OFFSET_LOW_CLAMP	STAGE0 offset low clamp value
0x088	[15:0]	X	R/W	STAGE1_CONNECTION[6:0]	STAGE1 CIN[6:0] connection setup (see Table 35)
0x089	[15:0]	X	R/W	STAGE1_CONNECTION[12:7]	STAGE1 CIN[12:7] connection setup (see Table 36)
0x08A	[15:0]	X	R/W	STAGE1_AFE_OFFSET	STAGE1 AFE offset control (see Table 37)
0x08B	[15:0]	X	R/W	STAGE1_SENSITIVITY	STAGE1 sensitivity control (see Table 38)
0x08C	[15:0]	X	R/W	STAGE1_OFFSET_LOW	STAGE1 initial offset low value
0x08D	[15:0]	X	R/W	STAGE1_OFFSET_HIGH	STAGE1 initial offset high value
0x08E	[15:0]	X	R/W	STAGE1_OFFSET_HIGH_CLAMP	STAGE1 offset high clamp value
0x08F	[15:0]	X	R/W	STAGE1_OFFSET_LOW_CLAMP	STAGE1 offset low clamp value
0x090	[15:0]	X	R/W	STAGE2_CONNECTION[6:0]	STAGE2 CIN[6:0] connection setup (see Table 35)
0x091	[15:0]	X	R/W	STAGE2_CONNECTION[12:7]	STAGE2 CIN[12:7] connection setup (see Table 36)
0x092	[15:0]	X	R/W	STAGE2_AFE_OFFSET	STAGE2 AFE offset control (see Table 37)
0x093	[15:0]	X	R/W	STAGE2_SENSITIVITY	STAGE2 sensitivity control (see Table 38)
0x094	[15:0]	X	R/W	STAGE2_OFFSET_LOW	STAGE2 initial offset low value
0x095	[15:0]	X	R/W	STAGE2_OFFSET_HIGH	STAGE2 initial offset high value
0x096	[15:0]	X	R/W	STAGE2_OFFSET_HIGH_CLAMP	STAGE2 offset high clamp value
0x097	[15:0]	X	R/W	STAGE2_OFFSET_LOW_CLAMP	STAGE2 offset low clamp value
0x098	[15:0]	X	R/W	STAGE3_CONNECTION[6:0]	STAGE3 CIN[6:0] connection setup (see Table 35)
0x099	[15:0]	X	R/W	STAGE3_CONNECTION[12:7]	STAGE3 CIN[12:7] connection setup (see Table 36)
0x09A	[15:0]	X	R/W	STAGE3_AFE_OFFSET	STAGE3 AFE offset control (see Table 37)
0x09B	[15:0]	X	R/W	STAGE3_SENSITIVITY	STAGE3 sensitivity control (see Table 38)
0x09C	[15:0]	X	R/W	STAGE3_OFFSET_LOW	STAGE3 initial offset low value
0x09D	[15:0]	X	R/W	STAGE3_OFFSET_HIGH	STAGE3 initial offset high value
0x09E	[15:0]	X	R/W	STAGE3_OFFSET_HIGH_CLAMP	STAGE3 offset high clamp value
0x09F	[15:0]	X	R/W	STAGE3_OFFSET_LOW_CLAMP	STAGE3 offset low clamp value
0x0A0	[15:0]	X	R/W	STAGE4_CONNECTION[6:0]	STAGE4 CIN[6:0] connection setup (see Table 35)
0x0A1	[15:0]	X	R/W	STAGE4_CONNECTION[12:7]	STAGE4 CIN[12:7] connection setup (see Table 36)
0x0A2	[15:0]	X	R/W	STAGE4_AFE_OFFSET	STAGE4 AFE offset control (see Table 37)
0x0A3	[15:0]	X	R/W	STAGE4_SENSITIVITY	STAGE4 sensitivity control (see Table 38)
0x0A4	[15:0]	X	R/W	STAGE4_OFFSET_LOW	STAGE4 initial offset low value
0x0A5	[15:0]	X	R/W	STAGE4_OFFSET_HIGH	STAGE4 initial offset high value
0x0A6	[15:0]	X	R/W	STAGE4_OFFSET_HIGH_CLAMP	STAGE4 offset high clamp value
0x0A7	[15:0]	X	R/W	STAGE4_OFFSET_LOW_CLAMP	STAGE4 offset low clamp value
0x0A8	[15:0]	X	R/W	STAGE5_CONNECTION[6:0]	STAGE5 CIN[6:0] connection setup (see Table 35)
0x0A9	[15:0]	X	R/W	STAGE5_CONNECTION[12:7]	STAGE5 CIN[12:7] connection setup (see Table 36)
0x0AA	[15:0]	X	R/W	STAGE5_AFE_OFFSET	STAGE5 AFE offset control (see Table 37)
0x0AB	[15:0]	X	R/W	STAGE5_SENSITIVITY	STAGE5 sensitivity control (see Table 38)
0x0AC	[15:0]	X	R/W	STAGE5_OFFSET_LOW	STAGE5 initial offset low value
0x0AD	[15:0]	X	R/W	STAGE5_OFFSET_HIGH	STAGE5 initial offset high value
0x0AE	[15:0]	X	R/W	STAGE5_OFFSET_HIGH_CLAMP	STAGE5 offset high clamp value
0x0AF	[15:0]	X	R/W	STAGE5_OFFSET_LOW_CLAMP	STAGE5 offset low clamp value



Address	Data Bit	Default <sup>1</sup>	Type	Name	Description
0x0B0	[15:0]	X	R/W	STAGE6_CONNECTION[6:0]	STAGE6 CIN[6:0] connection setup (see Table 35)
0x0B1	[15:0]	X	R/W	STAGE6_CONNECTION[12:7]	STAGE6 CIN[12:7] connection setup (see Table 36)
0x0B2	[15:0]	X	R/W	STAGE6_AFE_OFFSET	STAGE6 AFE offset control (see Table 37)
0x0B3	[15:0]	X	R/W	STAGE6_SENSITIVITY	STAGE6 sensitivity control (see Table 38)
0x0B4	[15:0]	X	R/W	STAGE6_OFFSET_LOW	STAGE6 initial offset low value
0x0B5	[15:0]	X	R/W	STAGE6_OFFSET_HIGH	STAGE6 initial offset high value
0x0B6	[15:0]	X	R/W	STAGE6_OFFSET_HIGH_CLAMP	STAGE6 offset high clamp value
0x0B7	[15:0]	X	R/W	STAGE6_OFFSET_LOW_CLAMP	STAGE6 offset low clamp value
0x0B8	[15:0]	X	R/W	STAGE7_CONNECTION[6:0]	STAGE7 CIN[6:0] connection setup (see Table 35)
0x0B9	[15:0]	X	R/W	STAGE7_CONNECTION[12:7]	STAGE7 CIN[12:7] connection setup (see Table 36)
0x0BA	[15:0]	X	R/W	STAGE7_AFE_OFFSET	STAGE7 AFE offset control (see Table 37)
0x0BB	[15:0]	X	R/W	STAGE7_SENSITIVITY	STAGE7 sensitivity control (see Table 38)
0x0BC	[15:0]	X	R/W	STAGE7_OFFSET_LOW	STAGE7 initial offset low value
0x0BD	[15:0]	X	R/W	STAGE7_OFFSET_HIGH	STAGE7 initial offset high value
0x0BE	[15:0]	X	R/W	STAGE7_OFFSET_HIGH_CLAMP	STAGE7 offset high clamp value
0x0BF	[15:0]	X	R/W	STAGE7_OFFSET_LOW_CLAMP	STAGE7 offset low clamp value
0x0C0	[15:0]	X	R/W	STAGE8_CONNECTION[6:0]	STAGE8 CIN[6:0] connection setup (see Table 35)
0x0C1	[15:0]	X	R/W	STAGE8_CONNECTION[12:7]	STAGE8 CIN[12:7] connection setup (see Table 36)
0x0C2	[15:0]	X	R/W	STAGE8_AFE_OFFSET	STAGE8 AFE offset control (see Table 37)
0x0C3	[15:0]	X	R/W	STAGE8_SENSITIVITY	STAGE8 sensitivity control (see Table 38)
0x0C4	[15:0]	X	R/W	STAGE8_OFFSET_LOW	STAGE8 initial offset low value
0x0C5	[15:0]	X	R/W	STAGE8_OFFSET_HIGH	STAGE8 initial offset high value
0x0C6	[15:0]	X	R/W	STAGE8_OFFSET_HIGH_CLAMP	STAGE8 offset high clamp value
0x0C7	[15:0]	X	R/W	STAGE8_OFFSET_LOW_CLAMP	STAGE8 offset low clamp value
0x0C8	[15:0]	X	R/W	STAGE9_CONNECTION[6:0]	STAGE9 CIN[6:0] connection setup (see Table 35)
0x0C9	[15:0]	X	R/W	STAGE9_CONNECTION[12:7]	STAGE9 CIN[12:7] connection setup (see Table 36)
0x0CA	[15:0]	X	R/W	STAGE9_AFE_OFFSET	STAGE9 AFE offset control (see Table 37)
0x0CB	[15:0]	X	R/W	STAGE9_SENSITIVITY	STAGE9 sensitivity control (see Table 38)
0x0CC	[15:0]	X	R/W	STAGE9_OFFSET_LOW	STAGE9 initial offset low value
0x0CD	[15:0]	X	R/W	STAGE9_OFFSET_HIGH	STAGE9 initial offset high value
0x0CE	[15:0]	X	R/W	STAGE9_OFFSET_HIGH_CLAMP	STAGE9 offset high clamp value
0x0CF	[15:0]	X	R/W	STAGE9_OFFSET_LOW_CLAMP	STAGE9 offset low clamp value
0x0D0	[15:0]	X	R/W	STAGE10_CONNECTION[6:0]	STAGE10 CIN[6:0] connection setup (see Table 35)
0x0D1	[15:0]	X	R/W	STAGE10_CONNECTION[12:7]	STAGE10 CIN[12:7] connection setup (see Table 36)
0x0D2	[15:0]	X	R/W	STAGE10_AFE_OFFSET	STAGE10 AFE offset control (see Table 37)
0x0D3	[15:0]	X	R/W	STAGE10_SENSITIVITY	STAGE10 sensitivity control (see Table 38)
0x0D4	[15:0]	X	R/W	STAGE10_OFFSET_LOW	STAGE10 initial offset low value
0x0D5	[15:0]	X	R/W	STAGE10_OFFSET_HIGH	STAGE10 initial offset high value
0x0D6	[15:0]	X	R/W	STAGE10_OFFSET_HIGH_CLAMP	STAGE10 offset high clamp value
0x0D7	[15:0]	X	R/W	STAGE10_OFFSET_LOW_CLAMP	STAGE10 offset low clamp value
0x0D8	[15:0]	X	R/W	STAGE11_CONNECTION[6:0]	STAGE11 CIN[6:0] connection setup (see Table 35)
0x0D9	[15:0]	X	R/W	STAGE11_CONNECTION[12:7]	STAGE11 CIN[12:7] connection setup (see Table 36)
0x0DA	[15:0]	X	R/W	STAGE11_AFE_OFFSET	STAGE11 AFE offset control (see Table 37)
0x0DB	[15:0]	X	R/W	STAGE11_SENSITIVITY	STAGE11 sensitivity control (see Table 38)
0x0DC	[15:0]	X	R/W	STAGE11_OFFSET_LOW	STAGE11 initial offset low value
0x0DD	[15:0]	X	R/W	STAGE11_OFFSET_HIGH	STAGE11 initial offset high value
0x0DE	[15:0]	X	R/W	STAGE11_OFFSET_HIGH_CLAMP	STAGE11 offset high clamp value
0x0DF	[15:0]	X	R/W	STAGE11_OFFSET_LOW_CLAMP	STAGE11 offset low clamp value

<sup>1</sup> X = don't care.

# AD7147A

## BANK 3 REGISTERS

All address values are expressed in hexadecimal.

**Table 40. STAGE0 Results Registers**

Address	Data Bit	Default Value <sup>1</sup>	Type	Name	Description
0x0E0	[15:0]	X	R/W	STAGE0_CONV_DATA	STAGE0 CDC 16-bit conversion data (copy of CDC_RESULT_S0 register)
0x0E1	[15:0]	X	R/W	STAGE0_FF_WORD0	STAGE0 fast FIFO WORD0
0x0E2	[15:0]	X	R/W	STAGE0_FF_WORD1	STAGE0 fast FIFO WORD1
0x0E3	[15:0]	X	R/W	STAGE0_FF_WORD2	STAGE0 fast FIFO WORD2
0x0E4	[15:0]	X	R/W	STAGE0_FF_WORD3	STAGE0 fast FIFO WORD3
0x0E5	[15:0]	X	R/W	STAGE0_FF_WORD4	STAGE0 fast FIFO WORD4
0x0E6	[15:0]	X	R/W	STAGE0_FF_WORD5	STAGE0 fast FIFO WORD5
0x0E7	[15:0]	X	R/W	STAGE0_FF_WORD6	STAGE0 fast FIFO WORD6
0x0E8	[15:0]	X	R/W	STAGE0_FF_WORD7	STAGE0 fast FIFO WORD7
0x0E9	[15:0]	X	R/W	STAGE0_SF_WORD0	STAGE0 slow FIFO WORD0
0x0EA	[15:0]	X	R/W	STAGE0_SF_WORD1	STAGE0 slow FIFO WORD1
0x0EB	[15:0]	X	R/W	STAGE0_SF_WORD2	STAGE0 slow FIFO WORD2
0x0EC	[15:0]	X	R/W	STAGE0_SF_WORD3	STAGE0 slow FIFO WORD3
0x0ED	[15:0]	X	R/W	STAGE0_SF_WORD4	STAGE0 slow FIFO WORD4
0x0EE	[15:0]	X	R/W	STAGE0_SF_WORD5	STAGE0 slow FIFO WORD5
0x0EF	[15:0]	X	R/W	STAGE0_SF_WORD6	STAGE0 slow FIFO WORD6
0x0F0	[15:0]	X	R/W	STAGE0_SF_WORD7	STAGE0 slow FIFO WORD7
0x0F1	[15:0]	X	R/W	STAGE0_SF_AMBIENT	STAGE0 slow FIFO ambient value
0x0F2	[15:0]	X	R/W	STAGE0_FF_AVG	STAGE0 fast FIFO average value
0x0F3	[15:0]	X	R/W	STAGE0_PEAK_DETECT_WORD0	STAGE0 peak FIFO WORD0 value
0x0F4	[15:0]	X	R/W	STAGE0_PEAK_DETECT_WORD1	STAGE0 peak FIFO WORD1 value
0x0F5	[15:0]	X	R/W	STAGE0_MAX_WORD0	STAGE0 maximum value FIFO WORD0
0x0F6	[15:0]	X	R/W	STAGE0_MAX_WORD1	STAGE0 maximum value FIFO WORD1
0x0F7	[15:0]	X	R/W	STAGE0_MAX_WORD2	STAGE0 maximum value FIFO WORD2
0x0F8	[15:0]	X	R/W	STAGE0_MAX_WORD3	STAGE0 maximum value FIFO WORD3
0x0F9	[15:0]	X	R/W	STAGE0_MAX_AVG	STAGE0 average maximum FIFO value
0x0FA	[15:0]	X	R/W	STAGE0_HIGH_THRESHOLD	STAGE0 high threshold value
0x0FB	[15:0]	X	R/W	STAGE0_MAX_TEMP	STAGE0 temporary maximum value
0x0FC	[15:0]	X	R/W	STAGE0_MIN_WORD0	STAGE0 minimum value FIFO WORD0
0x0FD	[15:0]	X	R/W	STAGE0_MIN_WORD1	STAGE0 minimum value FIFO WORD1
0x0FE	[15:0]	X	R/W	STAGE0_MIN_WORD2	STAGE0 minimum value FIFO WORD2
0x0FF	[15:0]	X	R/W	STAGE0_MIN_WORD3	STAGE0 minimum value FIFO WORD3
0x100	[15:0]	X	R/W	STAGE0_MIN_AVG	STAGE0 average minimum FIFO value
0x101	[15:0]	X	R/W	STAGE0_LOW_THRESHOLD	STAGE0 low threshold value
0x102	[15:0]	X	R/W	STAGE0_MIN_TEMP	STAGE0 temporary minimum value
0x103	[15:0]	X	R/W	Unused	Set to 0

<sup>1</sup> X = don't care.

Table 41. STAGE1 Results Registers

Address	Data Bit	Default Value <sup>1</sup>	Type	Name	Description
0x104	[15:0]	X	R/W	STAGE1_CONV_DATA	STAGE1 CDC 16-bit conversion data (copy of CDC_RESULT_S1 register)
0x105	[15:0]	X	R/W	STAGE1_FF_WORD0	STAGE1 fast FIFO WORD0
0x106	[15:0]	X	R/W	STAGE1_FF_WORD1	STAGE1 fast FIFO WORD1
0x107	[15:0]	X	R/W	STAGE1_FF_WORD2	STAGE1 fast FIFO WORD2
0x108	[15:0]	X	R/W	STAGE1_FF_WORD3	STAGE1 fast FIFO WORD3
0x109	[15:0]	X	R/W	STAGE1_FF_WORD4	STAGE1 fast FIFO WORD4
0x10A	[15:0]	X	R/W	STAGE1_FF_WORD5	STAGE1 fast FIFO WORD5
0x10B	[15:0]	X	R/W	STAGE1_FF_WORD6	STAGE1 fast FIFO WORD6
0x10C	[15:0]	X	R/W	STAGE1_FF_WORD7	STAGE1 fast FIFO WORD7
0x10D	[15:0]	X	R/W	STAGE1_SF_WORD0	STAGE1 slow FIFO WORD0
0x10E	[15:0]	X	R/W	STAGE1_SF_WORD1	STAGE1 slow FIFO WORD1
0x10F	[15:0]	X	R/W	STAGE1_SF_WORD2	STAGE1 slow FIFO WORD2
0x110	[15:0]	X	R/W	STAGE1_SF_WORD3	STAGE1 slow FIFO WORD3
0x111	[15:0]	X	R/W	STAGE1_SF_WORD4	STAGE1 slow FIFO WORD4
0x112	[15:0]	X	R/W	STAGE1_SF_WORD5	STAGE1 slow FIFO WORD5
0x113	[15:0]	X	R/W	STAGE1_SF_WORD6	STAGE1 slow FIFO WORD6
0x114	[15:0]	X	R/W	STAGE1_SF_WORD7	STAGE1 slow FIFO WORD7
0x115	[15:0]	X	R/W	STAGE1_SF_AMBIENT	STAGE1 slow FIFO ambient value
0x116	[15:0]	X	R/W	STAGE1_FF_AVG	STAGE1 fast FIFO average value
0x117	[15:0]	X	R/W	STAGE1_PEAK_DETECT_WORD0	STAGE1 peak FIFO WORD0 value
0x118	[15:0]	X	R/W	STAGE1_PEAK_DETECT_WORD1	STAGE1 peak FIFO WORD1 value
0x119	[15:0]	X	R/W	STAGE1_MAX_WORD0	STAGE1 maximum value FIFO WORD0
0x11A	[15:0]	X	R/W	STAGE1_MAX_WORD1	STAGE1 maximum value FIFO WORD1
0x11B	[15:0]	X	R/W	STAGE1_MAX_WORD2	STAGE1 maximum value FIFO WORD2
0x11C	[15:0]	X	R/W	STAGE1_MAX_WORD3	STAGE1 maximum value FIFO WORD3
0x11D	[15:0]	X	R/W	STAGE1_MAX_AVG	STAGE1 average maximum FIFO value
0x11E	[15:0]	X	R/W	STAGE1_HIGH_THRESHOLD	STAGE1 high threshold value
0x11F	[15:0]	X	R/W	STAGE1_MAX_TEMP	STAGE1 temporary maximum value
0x120	[15:0]	X	R/W	STAGE1_MIN_WORD0	STAGE1 minimum value FIFO WORD0
0x121	[15:0]	X	R/W	STAGE1_MIN_WORD1	STAGE1 minimum value FIFO WORD1
0x122	[15:0]	X	R/W	STAGE1_MIN_WORD2	STAGE1 minimum value FIFO WORD2
0x123	[15:0]	X	R/W	STAGE1_MIN_WORD3	STAGE1 minimum value FIFO WORD3
0x124	[15:0]	X	R/W	STAGE1_MIN_AVG	STAGE1 average minimum FIFO value
0x125	[15:0]	X	R/W	STAGE1_LOW_THRESHOLD	STAGE1 low threshold value
0x126	[15:0]	X	R/W	STAGE1_MIN_TEMP	STAGE1 temporary minimum value
0x127	[15:0]	X	R/W	Unused	Set to 0

<sup>1</sup> X = don't care.

# AD7147A

**Table 42. STAGE2 Results Registers**

Address	Data Bit	Default Value <sup>1</sup>	Type	Name	Description
0x128	[15:0]	X	R/W	STAGE2_CONV_DATA	STAGE2 CDC 16-bit conversion data (copy of CDC_RESULT_S2 register)
0x129	[15:0]	X	R/W	STAGE2_FF_WORD0	STAGE2 fast FIFO WORD0
0x12A	[15:0]	X	R/W	STAGE2_FF_WORD1	STAGE2 fast FIFO WORD1
0x12B	[15:0]	X	R/W	STAGE2_FF_WORD2	STAGE2 fast FIFO WORD2
0x12C	[15:0]	X	R/W	STAGE2_FF_WORD3	STAGE2 fast FIFO WORD3
0x12D	[15:0]	X	R/W	STAGE2_FF_WORD4	STAGE2 fast FIFO WORD4
0x12E	[15:0]	X	R/W	STAGE2_FF_WORD5	STAGE2 fast FIFO WORD5
0x12F	[15:0]	X	R/W	STAGE2_FF_WORD6	STAGE2 fast FIFO WORD6
0x130	[15:0]	X	R/W	STAGE2_FF_WORD7	STAGE2 fast FIFO WORD7
0x131	[15:0]	X	R/W	STAGE2_SF_WORD0	STAGE2 slow FIFO WORD0
0x132	[15:0]	X	R/W	STAGE2_SF_WORD1	STAGE2 slow FIFO WORD1
0x133	[15:0]	X	R/W	STAGE2_SF_WORD2	STAGE2 slow FIFO WORD2
0x134	[15:0]	X	R/W	STAGE2_SF_WORD3	STAGE2 slow FIFO WORD3
0x135	[15:0]	X	R/W	STAGE2_SF_WORD4	STAGE2 slow FIFO WORD4
0x136	[15:0]	X	R/W	STAGE2_SF_WORD5	STAGE2 slow FIFO WORD5
0x137	[15:0]	X	R/W	STAGE2_SF_WORD6	STAGE2 slow FIFO WORD6
0x138	[15:0]	X	R/W	STAGE2_SF_WORD7	STAGE2 slow FIFO WORD7
0x139	[15:0]	X	R/W	STAGE2_SF_AMBIENT	STAGE2 slow FIFO ambient value
0x13A	[15:0]	X	R/W	STAGE2_FF_AVG	STAGE2 fast FIFO average value
0x13B	[15:0]	X	R/W	STAGE2_PEAK_DETECT_WORD0	STAGE2 peak FIFO WORD0 value
0x13C	[15:0]	X	R/W	STAGE2_PEAK_DETECT_WORD1	STAGE2 peak FIFO WORD1 value
0x13D	[15:0]	X	R/W	STAGE2_MAX_WORD0	STAGE2 maximum value FIFO WORD0
0x13E	[15:0]	X	R/W	STAGE2_MAX_WORD1	STAGE2 maximum value FIFO WORD1
0x13F	[15:0]	X	R/W	STAGE2_MAX_WORD2	STAGE2 maximum value FIFO WORD2
0x140	[15:0]	X	R/W	STAGE2_MAX_WORD3	STAGE2 maximum value FIFO WORD3
0x141	[15:0]	X	R/W	STAGE2_MAX_AVG	STAGE2 average maximum FIFO value
0x142	[15:0]	X	R/W	STAGE2_HIGH_THRESHOLD	STAGE2 high threshold value
0x143	[15:0]	X	R/W	STAGE2_MAX_TEMP	STAGE2 temporary maximum value
0x144	[15:0]	X	R/W	STAGE2_MIN_WORD0	STAGE2 minimum value FIFO WORD0
0x145	[15:0]	X	R/W	STAGE2_MIN_WORD1	STAGE2 minimum value FIFO WORD1
0x146	[15:0]	X	R/W	STAGE2_MIN_WORD2	STAGE2 minimum value FIFO WORD2
0x147	[15:0]	X	R/W	STAGE2_MIN_WORD3	STAGE2 minimum value FIFO WORD3
0x148	[15:0]	X	R/W	STAGE2_MIN_AVG	STAGE2 average minimum FIFO value
0x149	[15:0]	X	R/W	STAGE2_LOW_THRESHOLD	STAGE2 low threshold value
0x14A	[15:0]	X	R/W	STAGE2_MIN_TEMP	STAGE2 temporary minimum value
0x14B	[15:0]	X	R/W	Unused	Set to 0

<sup>1</sup> X = don't care.

Table 43. STAGE3 Results Registers

Address	Data Bit	Default Value <sup>1</sup>	Type	Name	Description
0x14C	[15:0]	X	R/W	STAGE3_CONV_DATA	STAGE3 CDC 16-bit conversion data (copy of CDC_RESULT_S3 register)
0x14D	[15:0]	X	R/W	STAGE3_FF_WORD0	STAGE3 fast FIFO WORD0
0x14E	[15:0]	X	R/W	STAGE3_FF_WORD1	STAGE3 fast FIFO WORD1
0x14F	[15:0]	X	R/W	STAGE3_FF_WORD2	STAGE3 fast FIFO WORD2
0x150	[15:0]	X	R/W	STAGE3_FF_WORD3	STAGE3 fast FIFO WORD3
0x151	[15:0]	X	R/W	STAGE3_FF_WORD4	STAGE3 fast FIFO WORD4
0x152	[15:0]	X	R/W	STAGE3_FF_WORD5	STAGE3 fast FIFO WORD5
0x153	[15:0]	X	R/W	STAGE3_FF_WORD6	STAGE3 fast FIFO WORD6
0x154	[15:0]	X	R/W	STAGE3_FF_WORD7	STAGE3 fast FIFO WORD7
0x155	[15:0]	X	R/W	STAGE3_SF_WORD0	STAGE3 slow FIFO WORD0
0x156	[15:0]	X	R/W	STAGE3_SF_WORD1	STAGE3 slow FIFO WORD1
0x157	[15:0]	X	R/W	STAGE3_SF_WORD2	STAGE3 slow FIFO WORD2
0x158	[15:0]	X	R/W	STAGE3_SF_WORD3	STAGE3 slow FIFO WORD3
0x159	[15:0]	X	R/W	STAGE3_SF_WORD4	STAGE3 slow FIFO WORD4
0x15A	[15:0]	X	R/W	STAGE3_SF_WORD5	STAGE3 slow FIFO WORD5
0x15B	[15:0]	X	R/W	STAGE3_SF_WORD6	STAGE3 slow FIFO WORD6
0x15C	[15:0]	X	R/W	STAGE3_SF_WORD7	STAGE3 slow FIFO WORD7
0x15D	[15:0]	X	R/W	STAGE3_SF_AMBIENT	STAGE3 slow FIFO ambient value
0x15E	[15:0]	X	R/W	STAGE3_FF_AVG	STAGE3 fast FIFO average value
0x15F	[15:0]	X	R/W	STAGE3_PEAK_DETECT_WORD0	STAGE3 peak FIFO WORD0 value
0x160	[15:0]	X	R/W	STAGE3_PEAK_DETECT_WORD1	STAGE3 peak FIFO WORD1 value
0x161	[15:0]	X	R/W	STAGE3_MAX_WORD0	STAGE3 maximum value FIFO WORD0
0x162	[15:0]	X	R/W	STAGE3_MAX_WORD1	STAGE3 maximum value FIFO WORD1
0x163	[15:0]	X	R/W	STAGE3_MAX_WORD2	STAGE3 maximum value FIFO WORD2
0x164	[15:0]	X	R/W	STAGE3_MAX_WORD3	STAGE3 maximum value FIFO WORD3
0x165	[15:0]	X	R/W	STAGE3_MAX_AVG	STAGE3 average maximum FIFO value
0x166	[15:0]	X	R/W	STAGE3_HIGH_THRESHOLD	STAGE3 high threshold value
0x167	[15:0]	X	R/W	STAGE3_MAX_TEMP	STAGE3 temporary maximum value
0x168	[15:0]	X	R/W	STAGE3_MIN_WORD0	STAGE3 minimum value FIFO WORD0
0x169	[15:0]	X	R/W	STAGE3_MIN_WORD1	STAGE3 minimum value FIFO WORD1
0x16A	[15:0]	X	R/W	STAGE3_MIN_WORD2	STAGE3 minimum value FIFO WORD2
0x16B	[15:0]	X	R/W	STAGE3_MIN_WORD3	STAGE3 minimum value FIFO WORD3
0x16C	[15:0]	X	R/W	STAGE3_MIN_AVG	STAGE3 average minimum FIFO value
0x16D	[15:0]	X	R/W	STAGE3_LOW_THRESHOLD	STAGE3 low threshold value
0x16E	[15:0]	X	R/W	STAGE3_MIN_TEMP	STAGE3 temporary minimum value
0x16F	[15:0]	X	R/W	Unused	Set to 0

<sup>1</sup> X = don't care.

# AD7147A

**Table 44. STAGE4 Results Registers**

Address	Data Bit	Default Value <sup>1</sup>	Type	Name	Description
0x170	[15:0]	X	R/W	STAGE4_CONV_DATA	STAGE4 CDC 16-bit conversion data (copy of CDC_RESULT_S4 register)
0x171	[15:0]	X	R/W	STAGE4_FF_WORD0	STAGE4 fast FIFO WORD0
0x172	[15:0]	X	R/W	STAGE4_FF_WORD1	STAGE4 fast FIFO WORD1
0x173	[15:0]	X	R/W	STAGE4_FF_WORD2	STAGE4 fast FIFO WORD2
0x174	[15:0]	X	R/W	STAGE4_FF_WORD3	STAGE4 fast FIFO WORD3
0x175	[15:0]	X	R/W	STAGE4_FF_WORD4	STAGE4 fast FIFO WORD4
0x176	[15:0]	X	R/W	STAGE4_FF_WORD5	STAGE4 fast FIFO WORD5
0x177	[15:0]	X	R/W	STAGE4_FF_WORD6	STAGE4 fast FIFO WORD6
0x178	[15:0]	X	R/W	STAGE4_FF_WORD7	STAGE4 fast FIFO WORD7
0x179	[15:0]	X	R/W	STAGE4_SF_WORD0	STAGE4 slow FIFO WORD0
0x17A	[15:0]	X	R/W	STAGE4_SF_WORD1	STAGE4 slow FIFO WORD1
0x17B	[15:0]	X	R/W	STAGE4_SF_WORD2	STAGE4 slow FIFO WORD2
0x17C	[15:0]	X	R/W	STAGE4_SF_WORD3	STAGE4 slow FIFO WORD3
0x17D	[15:0]	X	R/W	STAGE4_SF_WORD4	STAGE4 slow FIFO WORD4
0x17E	[15:0]	X	R/W	STAGE4_SF_WORD5	STAGE4 slow FIFO WORD5
0x17F	[15:0]	X	R/W	STAGE4_SF_WORD6	STAGE4 slow FIFO WORD6
0x180	[15:0]	X	R/W	STAGE4_SF_WORD7	STAGE4 slow FIFO WORD7
0x181	[15:0]	X	R/W	STAGE4_SF_AMBIENT	STAGE4 slow FIFO ambient value
0x182	[15:0]	X	R/W	STAGE4_FF_AVG	STAGE4 fast FIFO average value
0x183	[15:0]	X	R/W	STAGE4_PEAK_DETECT_WORD0	STAGE4 peak FIFO WORD0 value
0x184	[15:0]	X	R/W	STAGE4_PEAK_DETECT_WORD1	STAGE4 peak FIFO WORD1 value
0x185	[15:0]	X	R/W	STAGE4_MAX_WORD0	STAGE4 maximum value FIFO WORD0
0x186	[15:0]	X	R/W	STAGE4_MAX_WORD1	STAGE4 maximum value FIFO WORD1
0x187	[15:0]	X	R/W	STAGE4_MAX_WORD2	STAGE4 maximum value FIFO WORD2
0x188	[15:0]	X	R/W	STAGE4_MAX_WORD3	STAGE4 maximum value FIFO WORD3
0x189	[15:0]	X	R/W	STAGE4_MAX_AVG	STAGE4 average maximum FIFO value
0x18A	[15:0]	X	R/W	STAGE4_HIGH_THRESHOLD	STAGE4 high threshold value
0x18B	[15:0]	X	R/W	STAGE4_MAX_TEMP	STAGE4 temporary maximum value
0x18C	[15:0]	X	R/W	STAGE4_MIN_WORD0	STAGE4 minimum value FIFO WORD0
0x18D	[15:0]	X	R/W	STAGE4_MIN_WORD1	STAGE4 minimum value FIFO WORD1
0x18E	[15:0]	X	R/W	STAGE4_MIN_WORD2	STAGE4 minimum value FIFO WORD2
0x18F	[15:0]	X	R/W	STAGE4_MIN_WORD3	STAGE4 minimum value FIFO WORD3
0x190	[15:0]	X	R/W	STAGE4_MIN_AVG	STAGE4 average minimum FIFO value
0x191	[15:0]	X	R/W	STAGE4_LOW_THRESHOLD	STAGE4 low threshold value
0x192	[15:0]	X	R/W	STAGE4_MIN_TEMP	STAGE4 temporary minimum value
0x193	[15:0]	X	R/W	Unused	Set to 0

<sup>1</sup> X = don't care.

Table 45. STAGE5 Results Registers

Address	Data Bit	Default Value <sup>1</sup>	Type	Name	Description
0x194	[15:0]	X	R/W	STAGE5_CONV_DATA	STAGE5 CDC 16-bit conversion data (copy of CDC_RESULT_S5 register)
0x195	[15:0]	X	R/W	STAGE5_FF_WORD0	STAGE5 fast FIFO WORD0
0x196	[15:0]	X	R/W	STAGE5_FF_WORD1	STAGE5 fast FIFO WORD1
0x197	[15:0]	X	R/W	STAGE5_FF_WORD2	STAGE5 fast FIFO WORD2
0x198	[15:0]	X	R/W	STAGE5_FF_WORD3	STAGE5 fast FIFO WORD3
0x199	[15:0]	X	R/W	STAGE5_FF_WORD4	STAGE5 fast FIFO WORD4
0x19A	[15:0]	X	R/W	STAGE5_FF_WORD5	STAGE5 fast FIFO WORD5
0x19B	[15:0]	X	R/W	STAGE5_FF_WORD6	STAGE5 fast FIFO WORD6
0x19C	[15:0]	X	R/W	STAGE5_FF_WORD7	STAGE5 fast FIFO WORD7
0x19D	[15:0]	X	R/W	STAGE5_SF_WORD0	STAGE5 slow FIFO WORD0
0x19E	[15:0]	X	R/W	STAGE5_SF_WORD1	STAGE5 slow FIFO WORD1
0x19F	[15:0]	X	R/W	STAGE5_SF_WORD2	STAGE5 slow FIFO WORD2
0x1A0	[15:0]	X	R/W	STAGE5_SF_WORD3	STAGE5 slow FIFO WORD3
0x1A1	[15:0]	X	R/W	STAGE5_SF_WORD4	STAGE5 slow FIFO WORD4
0x1A2	[15:0]	X	R/W	STAGE5_SF_WORD5	STAGE5 slow FIFO WORD5
0x1A3	[15:0]	X	R/W	STAGE5_SF_WORD6	STAGE5 slow FIFO WORD6
0x1A4	[15:0]	X	R/W	STAGE5_SF_WORD7	STAGE5 slow FIFO WORD7
0x1A5	[15:0]	X	R/W	STAGE5_SF_AMBIENT	STAGE5 slow FIFO ambient value
0x1A6	[15:0]	X	R/W	STAGE5_FF_AVG	STAGE5 fast FIFO average value
0x1A7	[15:0]	X	R/W	STAGE5_PEAK_DETECT_WORD0	STAGE5 peak FIFO WORD0 value
0x1A8	[15:0]	X	R/W	STAGE5_PEAK_DETECT_WORD1	STAGE5 peak FIFO WORD1 value
0x1A9	[15:0]	X	R/W	STAGE5_MAX_WORD0	STAGE5 maximum value FIFO WORD0
0x1AA	[15:0]	X	R/W	STAGE5_MAX_WORD1	STAGE5 maximum value FIFO WORD1
0x1AB	[15:0]	X	R/W	STAGE5_MAX_WORD2	STAGE5 maximum value FIFO WORD2
0x1AC	[15:0]	X	R/W	STAGE5_MAX_WORD3	STAGE5 maximum value FIFO WORD3
0x1AD	[15:0]	X	R/W	STAGE5_MAX_AVG	STAGE5 average maximum FIFO value
0x1AE	[15:0]	X	R/W	STAGE5_HIGH_THRESHOLD	STAGE5 high threshold value
0x1AF	[15:0]	X	R/W	STAGE5_MAX_TEMP	STAGE5 temporary maximum value
0x1B0	[15:0]	X	R/W	STAGE5_MIN_WORD0	STAGE5 minimum value FIFO WORD0
0x1B1	[15:0]	X	R/W	STAGE5_MIN_WORD1	STAGE5 minimum value FIFO WORD1
0x1B2	[15:0]	X	R/W	STAGE5_MIN_WORD2	STAGE5 minimum value FIFO WORD2
0x1B3	[15:0]	X	R/W	STAGE5_MIN_WORD3	STAGE5 minimum value FIFO WORD3
0x1B4	[15:0]	X	R/W	STAGE5_MIN_AVG	STAGE5 average minimum FIFO value
0x1B5	[15:0]	X	R/W	STAGE5_LOW_THRESHOLD	STAGE5 low threshold value
0x1B6	[15:0]	X	R/W	STAGE5_MIN_TEMP	STAGE5 temporary minimum value
0x1B7	[15:0]	X	R/W	Unused	Set to 0

<sup>1</sup> X = don't care.

# AD7147A

**Table 46. STAGE6 Results Registers**

Address	Data Bit	Default Value <sup>1</sup>	Type	Name	Description
0x1B8	[15:0]	X	R/W	STAGE6_CONV_DATA	STAGE6 CDC 16-bit conversion data (copy of CDC_RESULT_S6 register)
0x1B9	[15:0]	X	R/W	STAGE6_FF_WORD0	STAGE6 fast FIFO WORD0
0x1BA	[15:0]	X	R/W	STAGE6_FF_WORD1	STAGE6 fast FIFO WORD1
0x1BB	[15:0]	X	R/W	STAGE6_FF_WORD2	STAGE6 fast FIFO WORD2
0x1BC	[15:0]	X	R/W	STAGE6_FF_WORD3	STAGE6 fast FIFO WORD3
0x1BD	[15:0]	X	R/W	STAGE6_FF_WORD4	STAGE6 fast FIFO WORD4
0x1BE	[15:0]	X	R/W	STAGE6_FF_WORD5	STAGE6 fast FIFO WORD5
0x1BF	[15:0]	X	R/W	STAGE6_FF_WORD6	STAGE6 fast FIFO WORD6
0x1C0	[15:0]	X	R/W	STAGE6_FF_WORD7	STAGE6 fast FIFO WORD7
0x1C1	[15:0]	X	R/W	STAGE6_SF_WORD0	STAGE6 slow FIFO WORD0
0x1C2	[15:0]	X	R/W	STAGE6_SF_WORD1	STAGE6 slow FIFO WORD1
0x1C3	[15:0]	X	R/W	STAGE6_SF_WORD2	STAGE6 slow FIFO WORD2
0x1C4	[15:0]	X	R/W	STAGE6_SF_WORD3	STAGE6 slow FIFO WORD3
0x1C5	[15:0]	X	R/W	STAGE6_SF_WORD4	STAGE6 slow FIFO WORD4
0x1C6	[15:0]	X	R/W	STAGE6_SF_WORD5	STAGE6 slow FIFO WORD5
0x1C7	[15:0]	X	R/W	STAGE6_SF_WORD6	STAGE6 slow FIFO WORD6
0x1C8	[15:0]	X	R/W	STAGE6_SF_WORD7	STAGE6 slow FIFO WORD7
0x1C9	[15:0]	X	R/W	STAGE6_SF_AMBIENT	STAGE6 slow FIFO ambient value
0x1CA	[15:0]	X	R/W	STAGE6_FF_AVG	STAGE6 fast FIFO average value
0x1CB	[15:0]	X	R/W	STAGE6_PEAK_DETECT_WORD0	STAGE6 peak FIFO WORD0 value
0x1CC	[15:0]	X	R/W	STAGE6_PEAK_DETECT_WORD1	STAGE6 peak FIFO WORD1 value
0x1CD	[15:0]	X	R/W	STAGE6_MAX_WORD0	STAGE6 maximum value FIFO WORD0
0x1CE	[15:0]	X	R/W	STAGE6_MAX_WORD1	STAGE6 maximum value FIFO WORD1
0x1CF	[15:0]	X	R/W	STAGE6_MAX_WORD2	STAGE6 maximum value FIFO WORD2
0x1D0	[15:0]	X	R/W	STAGE6_MAX_WORD3	STAGE6 maximum value FIFO WORD3
0x1D1	[15:0]	X	R/W	STAGE6_MAX_AVG	STAGE6 average maximum FIFO value
0x1D2	[15:0]	X	R/W	STAGE6_HIGH_THRESHOLD	STAGE6 high threshold value
0x1D3	[15:0]	X	R/W	STAGE6_MAX_TEMP	STAGE6 temporary maximum value
0x1D4	[15:0]	X	R/W	STAGE6_MIN_WORD0	STAGE6 minimum value FIFO WORD0
0x1D5	[15:0]	X	R/W	STAGE6_MIN_WORD1	STAGE6 minimum value FIFO WORD1
0x1D6	[15:0]	X	R/W	STAGE6_MIN_WORD2	STAGE6 minimum value FIFO WORD2
0x1D7	[15:0]	X	R/W	STAGE6_MIN_WORD3	STAGE6 minimum value FIFO WORD3
0x1D8	[15:0]	X	R/W	STAGE6_MIN_AVG	STAGE6 average minimum FIFO value
0x1D9	[15:0]	X	R/W	STAGE6_LOW_THRESHOLD	STAGE6 low threshold value
0x1DA	[15:0]	X	R/W	STAGE6_MIN_TEMP	STAGE6 temporary minimum value
0x1DB	[15:0]	X	R/W	Unused	Set to 0

<sup>1</sup> X = don't care.



Table 47. STAGE7 Results Registers

Address	Data Bit	Default Value <sup>1</sup>	Type	Name	Description
0x1DC	[15:0]	X	R/W	STAGE7_CONV_DATA	STAGE7 CDC 16-bit conversion data (copy of CDC_RESULT_S7 register)
0x1DD	[15:0]	X	R/W	STAGE7_FF_WORD0	STAGE7 fast FIFO WORD0
0x1DE	[15:0]	X	R/W	STAGE7_FF_WORD1	STAGE7 fast FIFO WORD1
0x1DF	[15:0]	X	R/W	STAGE7_FF_WORD2	STAGE7 fast FIFO WORD2
0x1E0	[15:0]	X	R/W	STAGE7_FF_WORD3	STAGE7 fast FIFO WORD3
0x1E1	[15:0]	X	R/W	STAGE7_FF_WORD4	STAGE7 fast FIFO WORD4
0x1E2	[15:0]	X	R/W	STAGE7_FF_WORD5	STAGE7 fast FIFO WORD5
0x1E3	[15:0]	X	R/W	STAGE7_FF_WORD6	STAGE7 fast FIFO WORD6
0x1E4	[15:0]	X	R/W	STAGE7_FF_WORD7	STAGE7 fast FIFO WORD7
0x1E5	[15:0]	X	R/W	STAGE7_SF_WORD0	STAGE7 slow FIFO WORD0
0x1E6	[15:0]	X	R/W	STAGE7_SF_WORD1	STAGE7 slow FIFO WORD1
0x1E7	[15:0]	X	R/W	STAGE7_SF_WORD2	STAGE7 slow FIFO WORD2
0x1E8	[15:0]	X	R/W	STAGE7_SF_WORD3	STAGE7 slow FIFO WORD3
0x1E9	[15:0]	X	R/W	STAGE7_SF_WORD4	STAGE7 slow FIFO WORD4
0x1EA	[15:0]	X	R/W	STAGE7_SF_WORD5	STAGE7 slow FIFO WORD5
0x1EB	[15:0]	X	R/W	STAGE7_SF_WORD6	STAGE7 slow FIFO WORD6
0x1EC	[15:0]	X	R/W	STAGE7_SF_WORD7	STAGE7 slow FIFO WORD7
0x1ED	[15:0]	X	R/W	STAGE7_SF_AMBIENT	STAGE7 slow FIFO ambient value
0x1EE	[15:0]	X	R/W	STAGE7_FF_AVG	STAGE7 fast FIFO average value
0x1EF	[15:0]	X	R/W	STAGE7_PEAK_DETECT_WORD0	STAGE7 peak FIFO WORD0 value
0x1F0	[15:0]	X	R/W	STAGE7_PEAK_DETECT_WORD1	STAGE7 peak FIFO WORD1 value
0x1F1	[15:0]	X	R/W	STAGE7_MAX_WORD0	STAGE7 maximum value FIFO WORD0
0x1F2	[15:0]	X	R/W	STAGE7_MAX_WORD1	STAGE7 maximum value FIFO WORD1
0x1F3	[15:0]	X	R/W	STAGE7_MAX_WORD2	STAGE7 maximum value FIFO WORD2
0x1F4	[15:0]	X	R/W	STAGE7_MAX_WORD3	STAGE7 maximum value FIFO WORD3
0x1F5	[15:0]	X	R/W	STAGE7_MAX_AVG	STAGE7 average maximum FIFO value
0x1F6	[15:0]	X	R/W	STAGE7_HIGH_THRESHOLD	STAGE7 high threshold value
0x1F7	[15:0]	X	R/W	STAGE7_MAX_TEMP	STAGE7 temporary maximum value
0x1F8	[15:0]	X	R/W	STAGE7_MIN_WORD0	STAGE7 minimum value FIFO WORD0
0x1F9	[15:0]	X	R/W	STAGE7_MIN_WORD1	STAGE7 minimum value FIFO WORD1
0x1FA	[15:0]	X	R/W	STAGE7_MIN_WORD2	STAGE7 minimum value FIFO WORD2
0x1FB	[15:0]	X	R/W	STAGE7_MIN_WORD3	STAGE7 minimum value FIFO WORD3
0x1FC	[15:0]	X	R/W	STAGE7_MIN_AVG	STAGE7 average minimum FIFO value
0x1FD	[15:0]	X	R/W	STAGE7_LOW_THRESHOLD	STAGE7 low threshold value
0x1FE	[15:0]	X	R/W	STAGE7_MIN_TEMP	STAGE7 temporary minimum value
0x1FF	[15:0]	X	R/W	Unused	Set to 0

<sup>1</sup> X = don't care.

# AD7147A

**Table 48. STAGE8 Results Registers**

Address	Data Bit	Default Value <sup>1</sup>	Type	Name	Description
0x200	[15:0]	X	R/W	STAGE8_CONV_DATA	STAGE8 CDC 16-bit conversion data (copy of CDC_RESULT_S8 register)
0x201	[15:0]	X	R/W	STAGE8_FF_WORD0	STAGE8 fast FIFO WORD0
0x202	[15:0]	X	R/W	STAGE8_FF_WORD1	STAGE8 fast FIFO WORD1
0x203	[15:0]	X	R/W	STAGE8_FF_WORD2	STAGE8 fast FIFO WORD2
0x204	[15:0]	X	R/W	STAGE8_FF_WORD3	STAGE8 fast FIFO WORD3
0x205	[15:0]	X	R/W	STAGE8_FF_WORD4	STAGE8 fast FIFO WORD4
0x206	[15:0]	X	R/W	STAGE8_FF_WORD5	STAGE8 fast FIFO WORD5
0x207	[15:0]	X	R/W	STAGE8_FF_WORD6	STAGE8 fast FIFO WORD6
0x208	[15:0]	X	R/W	STAGE8_FF_WORD7	STAGE8 fast FIFO WORD7
0x209	[15:0]	X	R/W	STAGE8_SF_WORD0	STAGE8 slow FIFO WORD0
0x20A	[15:0]	X	R/W	STAGE8_SF_WORD1	STAGE8 slow FIFO WORD1
0x20B	[15:0]	X	R/W	STAGE8_SF_WORD2	STAGE8 slow FIFO WORD2
0x20C	[15:0]	X	R/W	STAGE8_SF_WORD3	STAGE8 slow FIFO WORD3
0x20D	[15:0]	X	R/W	STAGE8_SF_WORD4	STAGE8 slow FIFO WORD4
0x20E	[15:0]	X	R/W	STAGE8_SF_WORD5	STAGE8 slow FIFO WORD5
0x20F	[15:0]	X	R/W	STAGE8_SF_WORD6	STAGE8 slow FIFO WORD6
0x210	[15:0]	X	R/W	STAGE8_SF_WORD7	STAGE8 slow FIFO WORD7
0x211	[15:0]	X	R/W	STAGE8_SF_AMBIENT	STAGE8 slow FIFO ambient value
0x212	[15:0]	X	R/W	STAGE8_FF_AVG	STAGE8 fast FIFO average value
0x213	[15:0]	X	R/W	STAGE8_PEAK_DETECT_WORD0	STAGE8 peak FIFO WORD0 value
0x214	[15:0]	X	R/W	STAGE8_PEAK_DETECT_WORD1	STAGE8 peak FIFO WORD1 value
0x215	[15:0]	X	R/W	STAGE8_MAX_WORD0	STAGE8 maximum value FIFO WORD0
0x216	[15:0]	X	R/W	STAGE8_MAX_WORD1	STAGE8 maximum value FIFO WORD1
0x217	[15:0]	X	R/W	STAGE8_MAX_WORD2	STAGE8 maximum value FIFO WORD2
0x218	[15:0]	X	R/W	STAGE8_MAX_WORD3	STAGE8 maximum value FIFO WORD3
0x219	[15:0]	X	R/W	STAGE8_MAX_AVG	STAGE8 average maximum FIFO value
0x21A	[15:0]	X	R/W	STAGE8_HIGH_THRESHOLD	STAGE8 high threshold value
0x21B	[15:0]	X	R/W	STAGE8_MAX_TEMP	STAGE8 temporary maximum value
0x21C	[15:0]	X	R/W	STAGE8_MIN_WORD0	STAGE8 minimum value FIFO WORD0
0x21D	[15:0]	X	R/W	STAGE8_MIN_WORD1	STAGE8 minimum value FIFO WORD1
0x21E	[15:0]	X	R/W	STAGE8_MIN_WORD2	STAGE8 minimum value FIFO WORD2
0x21F	[15:0]	X	R/W	STAGE8_MIN_WORD3	STAGE8 minimum value FIFO WORD3
0x220	[15:0]	X	R/W	STAGE8_MIN_AVG	STAGE8 average minimum FIFO value
0x221	[15:0]	X	R/W	STAGE8_LOW_THRESHOLD	STAGE8 low threshold value
0x222	[15:0]	X	R/W	STAGE8_MIN_TEMP	STAGE7 temporary minimum value
0x223	[15:0]	X	R/W	Unused	Set to 0

<sup>1</sup> X = don't care.

Table 49. STAGE9 Results Registers

Address	Data Bit	Default Value <sup>1</sup>	Type	Name	Description
0x224	[15:0]	X	R/W	STAGE9_CONV_DATA	STAGE9 CDC 16-bit conversion data (copy of CDC_RESULT_S9 register)
0x225	[15:0]	X	R/W	STAGE9_FF_WORD0	STAGE9 fast FIFO WORD0
0x226	[15:0]	X	R/W	STAGE9_FF_WORD1	STAGE9 fast FIFO WORD1
0x227	[15:0]	X	R/W	STAGE9_FF_WORD2	STAGE9 fast FIFO WORD2
0x228	[15:0]	X	R/W	STAGE9_FF_WORD3	STAGE9 fast FIFO WORD3
0x229	[15:0]	X	R/W	STAGE9_FF_WORD4	STAGE9 fast FIFO WORD4
0x22A	[15:0]	X	R/W	STAGE9_FF_WORD5	STAGE9 fast FIFO WORD5
0x22B	[15:0]	X	R/W	STAGE9_FF_WORD6	STAGE9 fast FIFO WORD6
0x22C	[15:0]	X	R/W	STAGE9_FF_WORD7	STAGE9 fast FIFO WORD7
0x22D	[15:0]	X	R/W	STAGE9_SF_WORD0	STAGE9 slow FIFO WORD0
0x22E	[15:0]	X	R/W	STAGE9_SF_WORD1	STAGE9 slow FIFO WORD1
0x22F	[15:0]	X	R/W	STAGE9_SF_WORD2	STAGE9 slow FIFO WORD2
0x230	[15:0]	X	R/W	STAGE9_SF_WORD3	STAGE9 slow FIFO WORD3
0x231	[15:0]	X	R/W	STAGE9_SF_WORD4	STAGE9 slow FIFO WORD4
0x232	[15:0]	X	R/W	STAGE9_SF_WORD5	STAGE9 slow FIFO WORD5
0x233	[15:0]	X	R/W	STAGE9_SF_WORD6	STAGE9 slow FIFO WORD6
0x234	[15:0]	X	R/W	STAGE9_SF_WORD7	STAGE9 slow FIFO WORD7
0x235	[15:0]	X	R/W	STAGE9_SF_AMBIENT	STAGE9 slow FIFO ambient value
0x236	[15:0]	X	R/W	STAGE9_FF_AVG	STAGE9 fast FIFO average value
0x237	[15:0]	X	R/W	STAGE9_PEAK_DETECT_WORD0	STAGE9 peak FIFO WORD0 value
0x238	[15:0]	X	R/W	STAGE9_PEAK_DETECT_WORD1	STAGE9 peak FIFO WORD1 value
0x239	[15:0]	X	R/W	STAGE9_MAX_WORD0	STAGE9 maximum value FIFO WORD0
0x23A	[15:0]	X	R/W	STAGE9_MAX_WORD1	STAGE9 maximum value FIFO WORD1
0x23B	[15:0]	X	R/W	STAGE9_MAX_WORD2	STAGE9 maximum value FIFO WORD2
0x23C	[15:0]	X	R/W	STAGE9_MAX_WORD3	STAGE9 maximum value FIFO WORD3
0x23D	[15:0]	X	R/W	STAGE9_MAX_AVG	STAGE9 average maximum FIFO value
0x23E	[15:0]	X	R/W	STAGE9_HIGH_THRESHOLD	STAGE9 high threshold value
0x23F	[15:0]	X	R/W	STAGE9_MAX_TEMP	STAGE9 temporary maximum value
0x240	[15:0]	X	R/W	STAGE9_MIN_WORD0	STAGE9 minimum value FIFO WORD0
0x241	[15:0]	X	R/W	STAGE9_MIN_WORD1	STAGE9 minimum value FIFO WORD1
0x242	[15:0]	X	R/W	STAGE9_MIN_WORD2	STAGE9 minimum value FIFO WORD2
0x243	[15:0]	X	R/W	STAGE9_MIN_WORD3	STAGE9 minimum value FIFO WORD3
0x244	[15:0]	X	R/W	STAGE9_MIN_AVG	STAGE9 average minimum FIFO value
0x245	[15:0]	X	R/W	STAGE9_LOW_THRESHOLD	STAGE9 low threshold value
0x246	[15:0]	X	R/W	STAGE9_MIN_TEMP	STAGE9 temporary minimum value
0x247	[15:0]	X	R/W	Unused	Set to 0

<sup>1</sup> X = don't care.

# AD7147A

**Table 50. STAGE10 Results Registers**

Address	Data Bit	Default Value <sup>1</sup>	Type	Name	Description
0x248	[15:0]	X	R/W	STAGE10_CONV_DATA	STAGE10 CDC 16-bit conversion data (copy of CDC_RESULT_S10 register)
0x249	[15:0]	X	R/W	STAGE10_FF_WORD0	STAGE10 fast FIFO WORD0
0x24A	[15:0]	X	R/W	STAGE10_FF_WORD1	STAGE10 fast FIFO WORD1
0x24B	[15:0]	X	R/W	STAGE10_FF_WORD2	STAGE10 fast FIFO WORD2
0x24C	[15:0]	X	R/W	STAGE10_FF_WORD3	STAGE10 fast FIFO WORD3
0x24D	[15:0]	X	R/W	STAGE10_FF_WORD4	STAGE10 fast FIFO WORD4
0x24E	[15:0]	X	R/W	STAGE10_FF_WORD5	STAGE10 fast FIFO WORD5
0x24F	[15:0]	X	R/W	STAGE10_FF_WORD6	STAGE10 fast FIFO WORD6
0x250	[15:0]	X	R/W	STAGE10_FF_WORD7	STAGE10 fast FIFO WORD7
0x251	[15:0]	X	R/W	STAGE10_SF_WORD0	STAGE10 slow FIFO WORD0
0x252	[15:0]	X	R/W	STAGE10_SF_WORD1	STAGE10 slow FIFO WORD1
0x253	[15:0]	X	R/W	STAGE10_SF_WORD2	STAGE10 slow FIFO WORD2
0x254	[15:0]	X	R/W	STAGE10_SF_WORD3	STAGE10 slow FIFO WORD3
0x255	[15:0]	X	R/W	STAGE10_SF_WORD4	STAGE10 slow FIFO WORD4
0x256	[15:0]	X	R/W	STAGE10_SF_WORD5	STAGE10 slow FIFO WORD5
0x257	[15:0]	X	R/W	STAGE10_SF_WORD6	STAGE10 slow FIFO WORD6
0x258	[15:0]	X	R/W	STAGE10_SF_WORD7	STAGE10 slow FIFO WORD7
0x259	[15:0]	X	R/W	STAGE10_SF_AMBIENT	STAGE10 slow FIFO ambient value
0x25A	[15:0]	X	R/W	STAGE10_FF_AVG	STAGE10 fast FIFO average value
0x25B	[15:0]	X	R/W	STAGE10_PEAK_DETECT_WORD0	STAGE10 peak FIFO WORD0 value
0x25C	[15:0]	X	R/W	STAGE10_PEAK_DETECT_WORD1	STAGE10 peak FIFO WORD1 value
0x25D	[15:0]	X	R/W	STAGE10_MAX_WORD0	STAGE10 maximum value FIFO WORD0
0x25E	[15:0]	X	R/W	STAGE10_MAX_WORD1	STAGE10 maximum value FIFO WORD1
0x25F	[15:0]	X	R/W	STAGE10_MAX_WORD2	STAGE10 maximum value FIFO WORD2
0x260	[15:0]	X	R/W	STAGE10_MAX_WORD3	STAGE10 maximum value FIFO WORD3
0x261	[15:0]	X	R/W	STAGE10_MAX_AVG	STAGE10 average maximum FIFO value
0x262	[15:0]	X	R/W	STAGE10_HIGH_THRESHOLD	STAGE10 high threshold value
0x263	[15:0]	X	R/W	STAGE10_MAX_TEMP	STAGE10 temporary maximum value
0x264	[15:0]	X	R/W	STAGE10_MIN_WORD0	STAGE10 minimum value FIFO WORD0
0x265	[15:0]	X	R/W	STAGE10_MIN_WORD1	STAGE10 minimum value FIFO WORD1
0x266	[15:0]	X	R/W	STAGE10_MIN_WORD2	STAGE10 minimum value FIFO WORD2
0x267	[15:0]	X	R/W	STAGE10_MIN_WORD3	STAGE10 minimum value FIFO WORD3
0x268	[15:0]	X	R/W	STAGE10_MIN_AVG	STAGE10 average minimum FIFO value
0x269	[15:0]	X	R/W	STAGE10_LOW_THRESHOLD	STAGE10 low threshold value
0x26A	[15:0]	X	R/W	STAGE10_MIN_TEMP	STAGE10 temporary minimum value
0x26B	[15:0]	X	R/W	Unused	Set to 0

<sup>1</sup> X = don't care.

Table 51. STAGE11 Results Registers

Address	Data Bit	Default Value <sup>1</sup>	Type	Name	Description
0x26C	[15:0]	X	R/W	STAGE11_CONV_DATA	STAGE11 CDC 16-bit conversion data (copy of CDC_RESULT_S11 register)
0x26D	[15:0]	X	R/W	STAGE11_FF_WORD0	STAGE11 fast FIFO WORD0
0x26E	[15:0]	X	R/W	STAGE11_FF_WORD1	STAGE11 fast FIFO WORD1
0x26F	[15:0]	X	R/W	STAGE11_FF_WORD2	STAGE11 fast FIFO WORD2
0x270	[15:0]	X	R/W	STAGE11_FF_WORD3	STAGE11 fast FIFO WORD3
0x271	[15:0]	X	R/W	STAGE11_FF_WORD4	STAGE11 fast FIFO WORD4
0x272	[15:0]	X	R/W	STAGE11_FF_WORD5	STAGE11 fast FIFO WORD5
0x273	[15:0]	X	R/W	STAGE11_FF_WORD6	STAGE11 fast FIFO WORD6
0x274	[15:0]	X	R/W	STAGE11_FF_WORD7	STAGE11 fast FIFO WORD7
0x275	[15:0]	X	R/W	STAGE11_SF_WORD0	STAGE11 slow FIFO WORD0
0x276	[15:0]	X	R/W	STAGE11_SF_WORD1	STAGE11 slow FIFO WORD1
0x277	[15:0]	X	R/W	STAGE11_SF_WORD2	STAGE11 slow FIFO WORD2
0x278	[15:0]	X	R/W	STAGE11_SF_WORD3	STAGE11 slow FIFO WORD3
0x279	[15:0]	X	R/W	STAGE11_SF_WORD4	STAGE11 slow FIFO WORD4
0x27A	[15:0]	X	R/W	STAGE11_SF_WORD5	STAGE11 slow FIFO WORD5
0x27B	[15:0]	X	R/W	STAGE11_SF_WORD6	STAGE11 slow FIFO WORD6
0x27C	[15:0]	X	R/W	STAGE11_SF_WORD7	STAGE11 slow FIFO WORD7
0x27D	[15:0]	X	R/W	STAGE11_SF_AMBIENT	STAGE11 slow FIFO ambient value
0x27E	[15:0]	X	R/W	STAGE11_FF_AVG	STAGE11 fast FIFO average value
0x27F	[15:0]	X	R/W	STAGE11_PEAK_DETECT_WORD0	STAGE11 peak FIFO WORD0 value
0x280	[15:0]	X	R/W	STAGE11_PEAK_DETECT_WORD1	STAGE11 peak FIFO WORD1 value
0x281	[15:0]	X	R/W	STAGE11_MAX_WORD0	STAGE11 maximum value FIFO WORD0
0x282	[15:0]	X	R/W	STAGE11_MAX_WORD1	STAGE11 maximum value FIFO WORD1
0x283	[15:0]	X	R/W	STAGE11_MAX_WORD2	STAGE11 maximum value FIFO WORD2
0x284	[15:0]	X	R/W	STAGE11_MAX_WORD3	STAGE11 maximum value FIFO WORD3
0x285	[15:0]	X	R/W	STAGE11_MAX_AVG	STAGE11 average maximum FIFO value
0x286	[15:0]	X	R/W	STAGE11_HIGH_THRESHOLD	STAGE11 high threshold value
0x287	[15:0]	X	R/W	STAGE11_MAX_TEMP	STAGE11 temporary maximum value
0x288	[15:0]	X	R/W	STAGE11_MIN_WORD0	STAGE11 minimum value FIFO WORD0
0x289	[15:0]	X	R/W	STAGE11_MIN_WORD1	STAGE11 minimum value FIFO WORD1
0x28A	[15:0]	X	R/W	STAGE11_MIN_WORD2	STAGE11 minimum value FIFO WORD2
0x28B	[15:0]	X	R/W	STAGE11_MIN_WORD3	STAGE11 minimum value FIFO WORD3
0x28C	[15:0]	X	R/W	STAGE11_MIN_AVG	STAGE11 average minimum FIFO value
0x28D	[15:0]	X	R/W	STAGE11_LOW_THRESHOLD	STAGE11 low threshold value
0x28E	[15:0]	X	R/W	STAGE11_MIN_TEMP	STAGE11 temporary minimum value
0x28F	[15:0]	X	R/W	Unused	Set to 0

<sup>1</sup> X = don't care.

OUTLINE DIMENSIONS

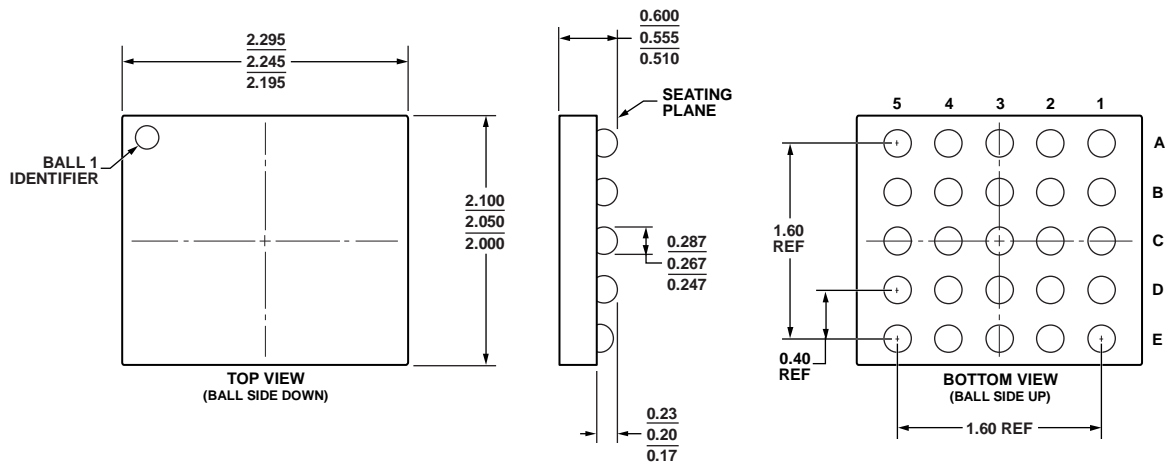

Figure 62. 25-Ball Wafer Level Chip Scale Package [WLCSP] (CB-25-3)

Dimensions shown in millimeters

081908-A

ORDERING GUIDE

Model	Temperature Range	Description	Serial Interface Description	Package Description	Package Option	Branding
AD7147AACBZ-RL <sup>1,2</sup>	-40°C to +85°C	Wake-up on proximity	SPI Interface	25-Ball WLCSP	CB-25-3	T3K
AD7147AACBZ500RL <sup>1,2</sup>	-40°C to +85°C	Wake-up on proximity	SPI Interface	25-Ball WLCSP	CB-25-3	T3K
AD7147A-1ACBZ-RL <sup>1,2</sup>	-40°C to +85°C	Wake-up on proximity	I <sup>2</sup> C Interface	25-Ball WLCSP	CB-25-3	T3J
AD7147A-1ACBZ500RL <sup>1,2</sup>	-40°C to +85°C	Wake-up on proximity	I <sup>2</sup> C Interface	25-Ball WLCSP	CB-25-3	T3J
EVAL-AD7147EBZ <sup>1</sup>			SPI Interface	Evaluation Board		
EVAL-AD7147-1EBZ <sup>1</sup>			I <sup>2</sup> C Interface	Evaluation Board		

<sup>1</sup> Z = RoHS Compliant Part.  
<sup>2</sup> This package is halide free.