

阅读申明

- 1.本站收集的数据手册和产品资料都来自互联网，版权归原作者所有。如读者和版权方有任何异议请及时告之，我们将妥善解决。
- 2.本站提供的中文数据手册是英文数据手册的中文翻译，其目的是协助用户阅读，该译文无法自动跟随原稿更新，同时也可能存在翻译上的不当。建议读者以英文原稿为参考以便获得更精准的信息。
- 3.本站提供的产品资料，来自厂商的技术支持或者使用者的心得体会等，其内容可能存在描述上的差异，建议读者做出适当判断。
- 4.如需与我们联系，请发邮件到marketing@iczoom.com，主题请标有“数据手册”字样。

Read Statement

1. The datasheets and other product information on the site are all from network reference or other public materials, and the copyright belongs to the original author and original published source. If readers and copyright owners have any objections, please contact us and we will deal with it in a timely manner.
2. The Chinese datasheets provided on the website is a Chinese translation of the English datasheets. Its purpose is for reader's learning exchange only and do not involve commercial purposes. The translation cannot be automatically updated with the original manuscript, and there may also be improper translations. Readers are advised to use the English manuscript as a reference for more accurate information.
3. All product information provided on the website refer to solutions from manufacturers' technical support or users the contents may have differences in description, and readers are advised to take the original article as the standard.
4. If you have any questions, please contact us at marketing@iczoom.com and mark the subject with "Datasheets" .



Low-Power, Ultra-Small Resistive Touch-Screen Controllers with I²C/SPI Interface

General Description

The MAX11800–MAX11803 low-power touch-screen controllers operate from a single supply of 1.70V to 3.6V, targeting power-sensitive applications such as handheld equipment. The devices contain a 12-bit SAR ADC and a multiplexer to interface with a resistive touch-screen panel. A digital serial interface provides communications.

The MAX11800–MAX11803 include digital preprocessing of the touch-screen measurements, reducing bus loading and application-processor resource requirements. The included smart interrupt function generator greatly reduces the frequency of interrupt servicing to the devices. The MAX11800–MAX11803 enter low-power modes automatically between conversions to save power, making the devices ideal for portable applications.

The MAX11800/MAX11801 offer two modes of operation: direct and autonomous. Direct mode allows the application processor to control all touch-screen controller activity. Autonomous mode allows the MAX11800/MAX11801 to control touch-screen activity, thereby freeing the application processor to perform other functions. In autonomous mode, the devices periodically scan the touch screen for touch events without requiring host-processor intervention. This can be used to reduce system power consumption. An on-chip FIFO is used during autonomous mode to store results, increasing effective data throughput and lower system power.

The MAX11800–MAX11803 support data-tagging, which records the type of measurement performed; X, Y, Z1, or Z2, and the type of touch event; initial touch, continuing touch, or touch release.

The MAX11800/MAX11802 support the SPI™ serial bus. The MAX11801/MAX11803 support the I²C serial bus. The MAX11800–MAX11803 are available in 12-pin TQFN and 12-pin WLP packages, and are specified over the -40°C to +85°C (extended) and -40°C to +105°C (automotive) temperature ranges.

Applications

Mobile Communication Devices	POS Terminals
PDA's, GPS Receivers, Personal Navigation Devices, Media Players	Handheld Games
Portable Instruments	Automotive Center Consoles

Typical Operating Circuits and Pin Configurations appear at end of data sheet.

SPI is a trademark of Motorola, Inc.

Features

- ◆ 4-Wire Touch-Screen Interface
- ◆ X/Y Coordinate and Touch Pressure Measurement
- ◆ Ratiometric Measurement
- ◆ 12-Bit SAR ADC
- ◆ Single 1.7V to 3.6V Supply
- ◆ Two Operating Modes—Direct and Autonomous
- ◆ Data Tagging Provides Measurement and Touch Event Information
- ◆ Data Filtering Provides Noise Reduction
- ◆ Aperture Mode Provides Spatial Filtering
- ◆ Digital Processing Reduces Bus Activity and Interrupt Generation
- ◆ Programmable Touch-Detect Pullup Resistors
- ◆ Auto Power-Down Control for Low-Power Operation
- ◆ 25MHz SPI Interface (MAX11800/MAX11802)
- ◆ 400kHz I²C Interface (MAX11801/MAX11803)
- ◆ 1.6mm x 2.1mm, 12-Pin WLP and 4mm x 4mm, 12-Pin TQFN
- ◆ Low-Power Operation
343μW at V_{DD} = 1.7V, 34.4ksps
888μW at V_{DD} = 3.3V, 34.4ksps
- ◆ ESD Protection
±4kV HBM
±8kV HBM (X+, X-, Y+, Y-)
±1kV CDM
±200V MM

Ordering Information

PART	TEMP RANGE	PIN-PACKAGE
MAX11800ETC+	-40°C to +85°C	12 TQFN-EP*
MAX11800GTC/N+	-40°C to +105°C	12 TQFN-EP*
MAX11800EWC+T	-40°C to +85°C	12 WLP
MAX11801ETC+	-40°C to +85°C	12 TQFN-EP*
MAX11801GTC/N+	-40°C to +105°C	12 TQFN-EP*
MAX11801EWC+T	-40°C to +85°C	12 WLP
MAX11802ETC+	-40°C to +85°C	12 TQFN-EP*
MAX11802EWC+T	-40°C to +85°C	12 WLP
MAX11803ETC+	-40°C to +85°C	12 TQFN-EP*
MAX11803EWC+T	-40°C to +85°C	12 WLP

+Denotes a lead(Pb)-free/RoHS-compliant package.

/N denotes an automotive qualified part.

T = Tape and reel.

*EP = Exposed pad.

MAX11800–MAX11803

Low-Power, Ultra-Small Resistive Touch-Screen Controllers with I²C/SPI Interface

TABLE OF CONTENTS

Absolute Maximum Ratings	8
Electrical Characteristics	8
I ² C Timing Characteristics	9
SPI Timing Characteristics	10
Typical Operating Characteristics	12
Pin Description	14
Functional Diagrams	15
Detailed Description	16
Position Measurements	16
Pressure Measurements	19
Touch-Detect Modes and Options	20
PUR and PUF	21
Idle Modes	21
Features Available in the MAX11800–MAX11803 Averaging Modes	21
Combined Commands	23
Data Tagging	23
Low-Power Modes	23
Features Available in the MAX11800/MAX11801 Only	24
Autonomous Mode	24
Aperture	24
Panel Setup, Measurement, and Scan Commands	24
Direct Conversion Mode Operations	24
Interrupt Modes	24
Panel Setup Commands	27
Panel Measurement Commands	27
Combined Commands	28
Auxiliary Measurement Command	28
Autonomous Conversion Mode	31
Measurement Operations	32
Combined Commands	32
Delayed Touch Detection During Mode Transitions	33
FIFO Memory	33
Clearing FIFO	33
FIFO Data Block Readback Structure	33
FIFO Data Word Structure	34
Block Readback Operations	34
Clearing Interrupt	34
Aperture Modes and Options	34
Aperture Range Requirements	34
FIFO Aperture Criteria	35
Applications Information	35
Using Aperture Mode	35

Low-Power, Ultra-Small Resistive Touch-Screen Controllers with I²C/SPI Interface

MAX11800-MAX11803

TABLE OF CONTENTS (continued)

Examples of Using Aperture Mode	36
SPI Communication Sequence (MAX11800/MAX11802)	38
SPI Configuration Register Write (MAX11800/MAX11802)	38
SPI Configuration or Result Register Read (MAX11800/MAX11802)	39
SPI Conversion Command (MAX11800/MAX11802)	40
I ² C-Supported Sequence (MAX11801/MAX11803)	40
Bit Transfer	40
START and STOP Conditions	40
Early STOP Conditions	41
Slave Address	41
I ² C Register Address	41
Acknowledge	41
Write Data Format	42
Read Data Format	43
Streamlined I ² C Read Operations	44
I ² C Conversion and Measurement Commands (MAX11801/MAX11803)	45
Command and Register Map	45
User-Accessible Registers	45
Status and Configuration Registers	46
Data Readback Commands	46
Autonomous Conversion Mode	46
Direct Conversion Mode	46
Panel Setup and Measurement Commands	48
User Configuration Registers	49
General Status Register (0x00) (Read Only)	49
General Configuration Register (0x01)	50
Measurement Resolution Configuration Register (0x02)	50
Measurement Averaging Configuration Register (0x03)	51
ADC Sampling Time Configuration Register (0x04)	51
Panel Setup Timing Configuration Register (0x05)	52
Delayed Conversion Configuration Register (0x06)	52
Touch-Detect Pullup Timing Configuration Register (0x07)	53
Autonomous Mode Timing Configuration Register (0x08)	54
Aperture Configuration Register (0x09)	54
Auxiliary Measurement Configuration Register (0x0A)	55
Operating Mode Configuration Register (0x0B)	56
MAX11800/MAX11802 Typical Operating Circuit	57
MAX11801/MAX11803 Typical Operating Circuit	57
Pin Configurations	58
Chip Information	58
Package Information	58
Revision History	59

Low-Power, Ultra-Small Resistive Touch-Screen Controllers with I²C/SPI Interface

LIST OF FIGURES

Figure 1. I ² C Timing Diagram	10
Figure 2. SPI Timing Diagram	11
Figure 3a. MAX11800/MAX11801 Operation Modes	17
Figure 3b. MAX11802/MAX11803 Operation Modes	18
Figure 4. Position Measurements	19
Figure 5. Pressure Measurements	19
Figure 6. Touch-Detection Circuitry	21
Figure 7. Touch-Detection Operations	22
Figure 8. State Machine Transitions (Direct Conversion Mode)—MAX11800–MAX11803	25
Figure 9. Continuous Interrupt Mode (Direct Conversion Mode)	26
Figure 10. Edge Interrupt Mode (Direct Conversion Mode)—MAX11800–MAX11803	27
Figure 11. Command and Measurement Flow (DCM)	28
Figure 12. Panel Setup and Measurement Commands—MAX11800–MAX11803	29
Figure 13. Combined Commands—MAX11800–MAX11803	30
Figure 14. State Machine Transitions—Autonomous Conversion Mode—MAX11800/MAX11801	31
Figure 15. Clear-on-Read Interrupt Operation—MAX11800/MAX11801	32
Figure 16. Aperture Usage Example Waveforms—MAX11800/MAX11801	36
Figure 17. SPI Single Configuration Register Write Sequence—MAX11800/MAX11802	38
Figure 18. SPI Multiple Configuration Register Write Sequence—MAX11800/MAX11802	38
Figure 19. SPI Single-Byte Register Read Sequence—MAX11800/MAX11802	39
Figure 20. SPI Multiple-Byte Register Read Sequence—MAX11800/MAX11802	40
Figure 21. SPI Conversion Command—MAX11800/MAX11802	40
Figure 22. 2-Wire Interface Timing Diagram	41
Figure 23. START, STOP, and Repeated START Conditions	41
Figure 24. Acknowledge	41
Figure 25. I ² C Single Write Sequence	42
Figure 26. I ² C Multiple Write Sequence	42
Figure 27. Basic Single Read Sequence	43
Figure 28. I ² C Multiple Read Sequence	43
Figure 29. I ² C Streamlined Read Sequence	44
Figure 30. I ² C Conversion and Measurement Commands	45

Low-Power, Ultra-Small Resistive Touch-Screen Controllers with I²C/SPI Interface

MAX11800-MAX11803

LIST OF TABLES

Table 1. Terminology	.6
Table 2. Operating Modes, Conditions, and Options	.19
Table 3. Summary of Physical Panel Settings for Supported Measurement Types	.20
Table 4. Median Averaging Operations	.23
Table 5. Data Word Structure (All Direct Conversion Modes)	.23
Table 6. Measurement and Event Tags (Continuous Interrupt Mode)	.25
Table 7. Measurement and Event Tags (Edge Interrupt Mode)	.26
Table 8. Panel Setup Command Summary	.27
Table 9. Panel Measurement Command Summary	.28
Table 10. FIFO Data Block Structure	.33
Table 11. FIFO Data Word Structure	.34
Table 12. FIFO Data Measurement Tags	.34
Table 13. FIFO Event Tags	.34
Table 14. Readback and FIFO Contents with Aperture Mode Enabled	.37
Table 15. Readback and FIFO Contents with Aperture Mode Disabled	.37
Table 16. SPI Command and Data Format: 8 Bits	.46
Table 17. I ² C Command and Data Format: 8 Bits Plus ACK	.46
Table 18. Status and Configuration Registers	.47
Table 19. Data Readback Command Summary	.47
Table 20. Conversion Command Summary	.48
Table 21. Measurement Commands	.49

Low-Power, Ultra-Small Resistive Touch-Screen Controllers with I²C/SPI Interface

Table 1. Terminology

TERM	DEFINITION
Panel, Touch Screen, Touch Panel	Resistive Touch Sensor: Panel, or touch screen, or touch panel are used interchangeably to denote the resistive touch sensor.
TSC	Touch-Screen Controller: Devices attached to a touch screen that provide the interface between an application processor (AP) and touch screen.
X+	X Position Positive I/O: Analog I/O from resistive touch screen. See Figure 4 for configuration and measurement details.
X-	X Position Negative I/O: Analog I/O from resistive touch screen. See Figure 4 for configuration and measurement details.
Y+	Y Position Positive I/O: Analog I/O from resistive touch screen. See Figure 4 for configuration and measurement details.
Y-	Y Position Negative I/O: Analog I/O from resistive touch screen. See Figure 4 for configuration and measurement details.
R _{TOUCH}	Touch Resistance: Represents the resistance between the X and Y planes of a resistive touch screen during a touch event.
Z1	Z1 Measurement: A resistive touch-screen measurement to determine the resistance between the two planes within the panel sensor during a touch event (R _{TOUCH}). See Figure 5 for configuration and measurement details.
Z2	Z2 Measurement: A resistive touch-screen measurement to determine the resistance between the two planes within the panel sensor during a touch event (R _{TOUCH}). See Figure 5 for configuration and measurement details.
AUX	Auxiliary Input: Analog input to the MAX11800–MAX11803 that can be used to monitor external conditions such as battery voltage or temperature.
ADC	Analog-to-Digital Converter: Circuit used to transform analog information into a form suitable for digital operations.
AP	Application Processor: An external microcontroller or microprocessor that interfaces to and controls the general operation of the MAX11800–MAX11803.
AVG	Averaging Mode: The ability to average consecutive measurement results to reduce noise from switch bounce, power-supply ripple, and incomplete settling.
MAF	Median Averaging Filter: The MAF first removes the minimum and maximum samples before taking the average of the remaining sample set.
SAF	Straight Averaging Filter: The SAF takes the average of an entire sample set.
TDM	Touch-Detect Mode: An untimed mode that monitors the panel for a touch using a user-selectable panel pullup resistor of either 50kΩ or 100kΩ.
DCM	Direct Conversion Mode: A mode of operation in which the AP requests individual panel setup and conversion operations or automated combinations of measurements (X and Y, X and Y and Z1, or X and Y and Z1 and Z2). The AP maintains control over the initiation of panel setup, measurements, and the sampling
ACM	Autonomous Conversion Mode: A mode of operation in which the MAX11800/MAX11801 idle in TDM until a touch event occurs. After a touch is detected, the MAX11800/MAX11801 begin an automated sequence of measurements determined by the user configuration registers.
PSU	Panel Setup Command: User-programmable modes for the purpose of allowing the panel sufficient time to settle, prior to the start of measurements. PSU commands configure the on-chip multiplexer in preparation to perform either X, Y, Z1, or Z2 measurements. Durations can either be specified and managed by the MAX11800–MAX11803 (in ACM and DCM) or managed by the AP (in DCM).
PMC	Panel Measurement Command: Individual measurements of X or Y position and Z1 or Z2 pressure measurements.
CMC	Combined Measurement Command: Combinations of PMCs (X and Y, X and Y and Z1, or X and Y and Z1 and Z2) offered by the MAX11800–MAX11803 and executed in series to reduce AP bus and interrupt activity.

Low-Power, Ultra-Small Resistive Touch-Screen Controllers with I²C/SPI Interface

MAX11800–MAX11803

Table 1. Terminology (continued)

TERM	DEFINITION
FIFO	First-In First-Out Memory: The MAX11800–MAX11803 contain a 1024-bit FIFO that is used to store conversion results when operating in autonomous conversion mode. FIFO depth indicates the number of words (16-bit quantity) in the FIFO.
Scan	Scan: Generally, a single sequence of operations performed in DCM or ACM. The operations could include a panel setup operation, followed by a panel measurement operation, or a combined measurement operation.
Scan Block	Scan Block: Generally, a sequence of multiple operations performed in DCM or ACM. The operations could include panel-setup operations, panel-measurement operations, or combined measurement operations.
Timed Scan	Timed Scan: A scan or scan block operation that uses the on-chip oscillator and timer. The timer is controlled through the configuration registers and represents an array of fixed (time) quantities that are user selectable (MAX11800/MAX11801).
Untimed Scan	Untimed Scan: A scan or scan block operation that is controlled by the AP. This only applies to DCM.
TAG	Data Tag: Information appended to the end of an ADC conversion result. Tags indicate the type of measurement and touch status associated with each panel observation. See the definitions for ETAG and MTAG (also in Table 1).
ETAG	Event Tag: Data tags indicating the panel touch status observed during a measurement.
MTAG	Measurement Tag: Data tag indicating the type of measurement read back by the AP (either X, Y, Z1, or Z2).
$\overline{\text{TIRQ}}$	Touch Interrupt Request: Active-low interrupt, indicating that a touch is present (CINT) or has been initiated (EINT) in DCM, or that new data is available in the FIFO in ACM.
EINT	Edge Interrupt Mode: Indicates, through $\overline{\text{TIRQ}}$, that a touch has been initiated (EINT) in DCM. The duration that $\overline{\text{TIRQ}}$ is low is user programmable.
CINT	Continuous Interrupt Mode: Indicates, through $\overline{\text{TIRQ}}$, that a touch is present (CINT) in DCM. $\overline{\text{TIRQ}}$ goes low to indicate the presence of a touch and stays low until the touch event ceases.
CORINT	Clear-on-Read Interrupt Mode: Used in ACM only. $\overline{\text{TIRQ}}$ goes low to indicate the presence of new FIFO data. The interrupt is cleared when the data is read by the AP (MAX11800/MAX11801).
APER	Aperture Mode: Available in ACM only. Reduces data writes to the FIFO by spatially filtering measurement data.
CONT	Continuous Bit: An option in DCM to return the MAX11800–MAX11803 to a panel setup (wait) mode (PSU) after a conversion, rather than a return to TDM (recommended only for applications with very long panel settling times and request controlling their own averaging). The continuous bit resides in bit 0 (R0) of the PSU and PMC registers.
LPM	Low-Power Mode: An idle mode used in DCM/EINT or ACM modes, when a touch is detected at the conclusion of the last measurement. This indicates a new measurement needs to be requested or scheduled (the touch-detect pullup is not engaged to save power).
PUR	Pullup Rough: A fast pullup mode, which uses the main X+ switch in parallel with the on-chip resistive pullup (50k Ω /100k Ω) to quickly slew the touch panel capacitances. R _{PUR} \leq 10 Ω typical.
PUF	Pullup Fine: A slow (fine) pullup mode, which uses the on-chip resistive pullup to slew the touch-panel capacitances to their final values (R _{PUF} = 50k Ω or 100k Ω) typical and is required for all applications.
SAR ADC	Successive Approximation Register ADC: An analog-to-digital converter that converts a continuous analog waveform into a discrete digital representation through a binary search through all possible quantization levels before finally converging upon a digital output for each conversion.
I ² C	Inter-Integrated Circuit: A multimaster serial computer bus that is used to attach low-speed peripherals to other components using two bidirectional open-drain lines, serial data (SDA) and serial clock (SCL), pulled up with resistors.
SPI	Serial Peripheral Interface: A serial interface in which a master device supplies clock pulses to exchange data serially with a slave over two data wires (master-slave and slave-master).

Low-Power, Ultra-Small Resistive Touch-Screen Controllers with I²C/SPI Interface

ABSOLUTE MAXIMUM RATINGS

V _{DD} to GND	-0.3V to +4.0V
X+, X-, Y+, Y-, AUX, TIRQ to GND	-0.3V to +4.0V
SCL, CLK, SDA, DIN, A0, CS, A1, DOUT to GND	-0.3V to +4.0V
Maximum Current into Any Pin	±50mA
Continuous Power Dissipation (T _A = +70°C)	
12-Pin TQFN (derate 24.4mW/°C above +70°C)	1951.2mW
12-Pin WLP (derate 6.5mW/°C above +70°C)	518.8mW

Operating Temperature Ranges

MAX1180_E_	-40°C to +85°C
MAX1180_G_	-40°C to +105°C
Storage Temperature Range	-65°C to +150°C
Junction Temperature	+150°C
Lead Temperature (excluding WLP, soldering, 10s)	+300°C
Soldering Temperature (reflow)	+260°C

Note 1: All WLP devices are 100% production tested at T_A = +25°C. Specifications over temperature limits are guaranteed by design and characterization.

Stresses beyond those listed under "Absolute Maximum Ratings" may cause permanent damage to the device. These are stress ratings only, and functional operation of the device at these or any other conditions beyond those indicated in the operational sections of the specifications is not implied. Exposure to absolute maximum rating conditions for extended periods may affect device reliability.

ELECTRICAL CHARACTERISTICS

(V_{DD} = 1.7V to 3.6V, T_A = -40°C to +85°C (MAX11800E-MAX11803E), T_A = -40°C to +105°C (MAX11800G/MAX11801G), unless otherwise noted. Typical values are at T_A = +25°C and V_{DD} = 3.3V, unless otherwise noted.)

PARAMETER	SYMBOL	CONDITIONS	MIN	TYP	MAX	UNITS
ADC						
ADC Resolution		No missing codes	10	11		Bits
Differential Nonlinearity	DNL	12-bit resolution		±1.5		LSB
Integral Nonlinearity	INL	12-bit resolution		±1.5		LSB
Offset Error				±2		LSB
Gain Error				±4		LSB
Throughput			105			ksp/s
TOUCH SENSORS (X+, X-, Y+, Y-, AUX)						
Switch On-Resistance		V _{DD} = 1.7V		7		Ω
		V _{DD} = 3.3V		5		
Switch Driver Current		100ms pulse			50	mA
Input Voltage Range			0		V _{DD}	V
POWER SUPPLY (V_{DD})						
Supply Voltage	V _{DD}		1.7		3.6	V
Supply Current		Power-down mode. All digital inputs static.	1.7V	0.2		μA
			3.6V	2		
		TDM. All digital inputs static. Does not include panel currents when touched.	3.6V	7		
			Timed LPM. All digital inputs static. Does not include panel currents when touched.	1.7V	9	
		3.3V		16		
		AUX conversions at 34.4ksp/s equivalent rate, SPI	1.7V	216		
			3.3V	273	550	
		AUX conversions at 34.4ksp/s equivalent rate, I ² C	1.7V	202		
3.3V	269		550			
Power Consumption		AUX conversions at 34.4ksp/s equivalent rate, SPI	1.7V	367		μW
			3.3V	901		
		AUX conversions at 34.4ksp/s equivalent rate, I ² C	1.7V	343		
			3.3V	888		

Low-Power, Ultra-Small Resistive Touch-Screen Controllers with I²C/SPI Interface

ELECTRICAL CHARACTERISTICS (continued)

(V_{DD} = 1.7V to 3.6V, T_A = -40°C to +85°C (MAX11800E-MAX11803E), T_A = -40°C to +105°C (MAX11800G/MAX11801G), unless otherwise noted. Typical values are at T_A = +25°C and V_{DD} = 3.3V, unless otherwise noted.)

PARAMETER	SYMBOL	CONDITIONS	MIN	TYP	MAX	UNITS
DIGITAL INPUTS (SDA, DIN, SCL, CLK, A0, CS, A1)						
Input Logic-High Voltage	V _{IH}		0.7 x V _{DD}			V
Input Logic-Low Voltage	V _{IL}				0.3 x V _{DD}	V
Input Leakage Current	I _{IN}	V _{IN} = 0V or V _{DD}	-1		+1	μA
Input Hysteresis	V _{HYS}			0.5 x V _{DD}		V
Input Capacitance				6		pF
DIGITAL OUTPUTS (SDA, DOUT, TIRQ)						
Output Logic-High	V _{OH}	DOUT, I _{SOURCE} = 1mA	0.9 x V _{DD}			V
		TIRQ, CMOS configuration, I _{SOURCE} = 1mA	0.9 x V _{DD}			
Output Logic-Low—TIRQ, DOUT	V _{OL}	I _{SINK} = 1mA			0.4	V
Output Logic-Low—SDA	V _{OL}	I _{SINK} = 3mA			0.4	V
TIRQ Pullup Resistor				125		kΩ

I²C TIMING CHARACTERISTICS

(V_{DD} = 1.7V to 3.6V, T_A = -40°C to +85°C (MAX11801E and MAX11803E), T_A = -40°C to +105°C (MAX11801G), unless otherwise noted. Typical values are at T_A = +25°C and V_{DD} = 3.3V, unless otherwise noted. See Figure 1.)

PARAMETER	SYMBOL	CONDITIONS	MIN	TYP	MAX	UNITS
Serial-Clock Frequency	f _{SCL}		0		400	kHz
Bus Free Time	t _{BUF}	Bus free time between STOP and START condition	1.3			μs
Hold Time for START Condition	t _{HD;STA}	After this period, the first clock pulse is generated	0.6			μs
SCL Pulse-Width Low	t _{LOW}		1.3			μs
SCL Pulse-Width High	t _{HIGH}		0.6			μs
Setup Time for Repeated START (Sr) Condition	t _{SU;STA}		0.6			μs
Data Hold Time	t _{HD;DAT}		0		900	ns
Data Setup Time	t _{SU;DAT}		100			ns
SDA and SCL Rise/Fall Time	t _R , t _F	Receiving	20 + C _B /10		300	ns
SDA and SCL Fall Time	t _{TF}	Transmitting	20 + C _B /10		250	ns
Setup Time for STOP Condition	t _{SU;STO}		0.6			μs
Bus Capacitance Allowed	C _B	V _{DD} = 1.7V to 2.7V	10		100	pF
		V _{DD} = 2.7V to 3.6V	10		400	
Pulse Width of Suppressed Spike	t _{SP}				50	ns

Low-Power, Ultra-Small Resistive Touch-Screen Controllers with I²C/SPI Interface

SPI TIMING CHARACTERISTICS

(V_{DD} = 1.7V to 3.6V, T_A = -40°C to +85°C (MAX11800E and MAX11802E), T_A = -40°C to +105°C (MAX11800G), unless otherwise noted. Typical values are at T_A = +25°C and V_{DD} = 3.3V, unless otherwise noted. See Figure 2.)

PARAMETER	SYMBOL	CONDITIONS	MIN	TYP	MAX	UNITS
CLK Frequency	f _{CLK}				25	MHz
CLK Period	t _{CP}		40			ns
CLK Pulse-Width High	t _{CH}		18			ns
CLK Pulse-Width Low	t _{CL}		18			ns
$\overline{\text{CS}}$ Low to 1st CLK Rise Setup	t _{CSS0}		18			ns
$\overline{\text{CS}}$ Low After 0th CLK Rise Hold	t _{CSh0}	To prevent a 0th CLK read from being taken as a 1st read in a free-running application	0			ns
$\overline{\text{CS}}$ High to 17th CLK Setup	t _{CSS1}	To prevent a 17th CLK read from being recognized by the device in a free-running application	18			ns
$\overline{\text{CS}}$ High After 16th CLK Falling Edge Hold	t _{CSh1}		0			ns
$\overline{\text{CS}}$ Pulse-Width High	t _{CSW}		18			ns
DIN to CLK Setup	t _{DS}		25			ns
DIN Hold After CLK	t _{DH}		0			ns
DOUT Transition Valid After CLK Rise	t _{DOT}	Output transition time			25	ns
DOUT Remains Valid After CLK Rise	t _{DOH}	Output hold time	3			ns
DOUT Valid Before CLK Rise	t _{DO1}	t _{DO1} = t _{CP} - t _{DOT}	10			ns
$\overline{\text{CS}}$ Rise to DOUT Disable	t _{DOD}	C _{LOAD} = 20pF			40	ns
CLK Rise to DOUT Enable	t _{DOE}	C _{LOAD} = 20pF. Minimum = hold time with regard to 8th CLK read. Maximum = transition time with regard to 8th CLK read.	3		25	ns

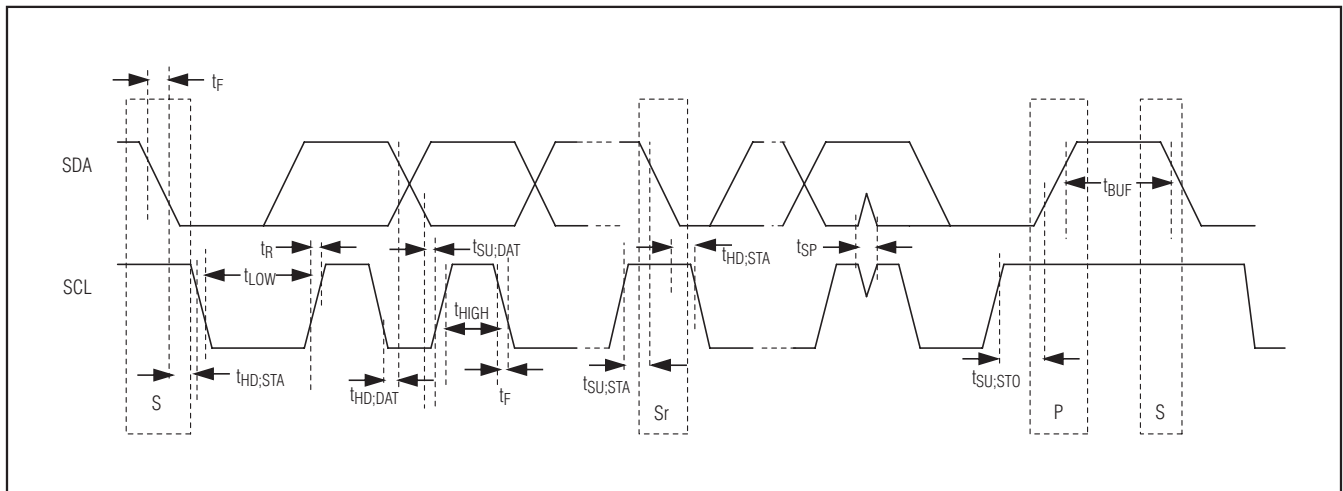

Figure 1. I²C Timing Diagram

Low-Power, Ultra-Small Resistive Touch-Screen Controllers with I²C/SPI Interface

MAX11800-MAX11803

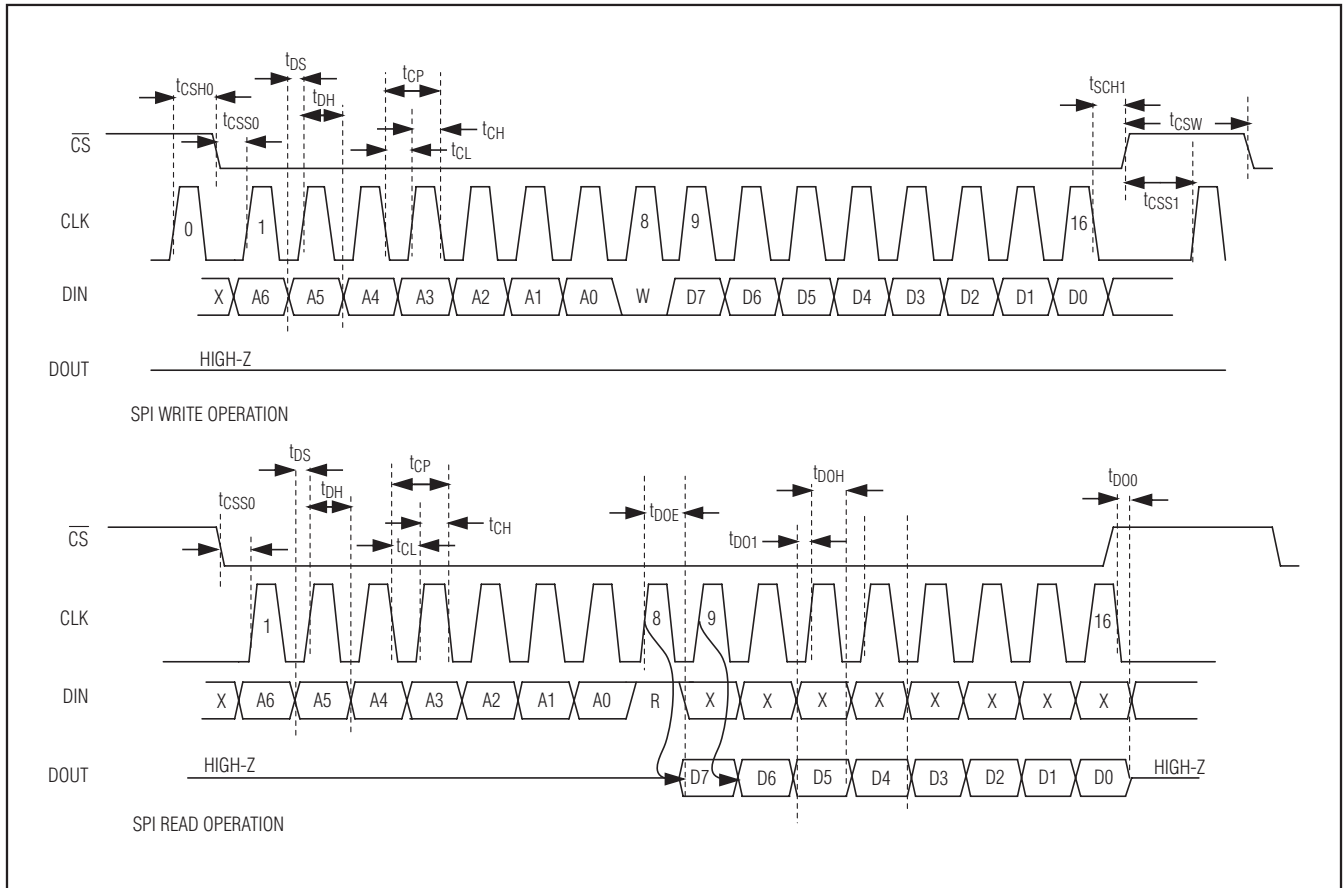
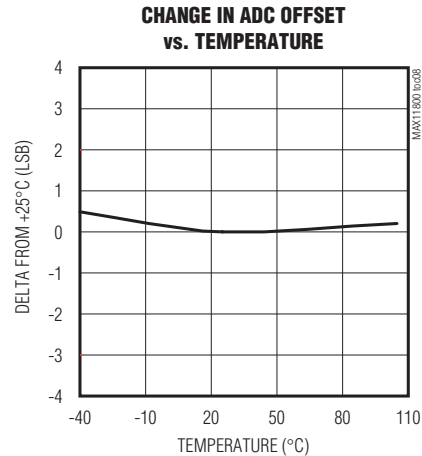
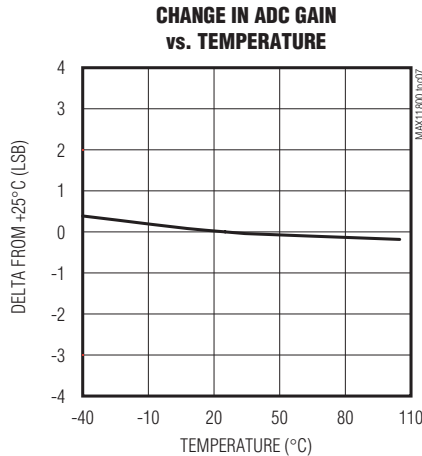
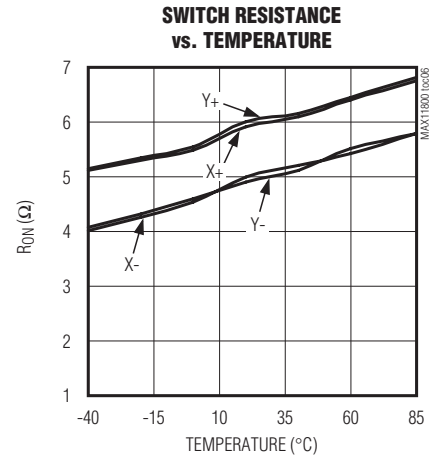
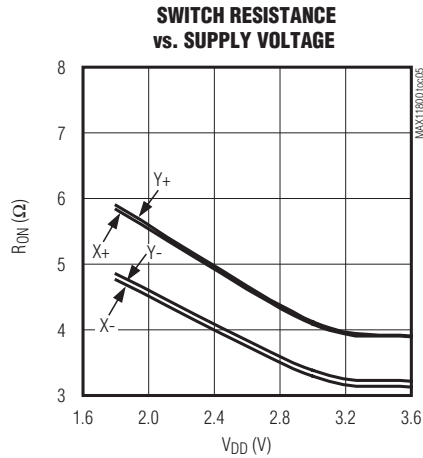
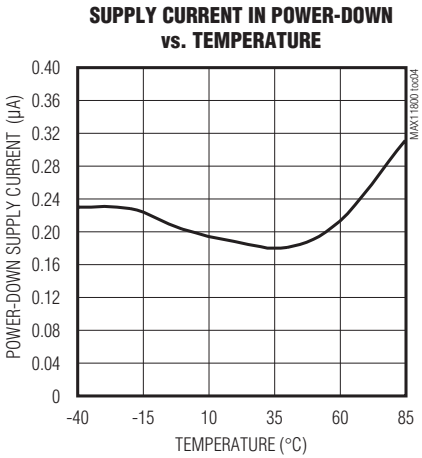
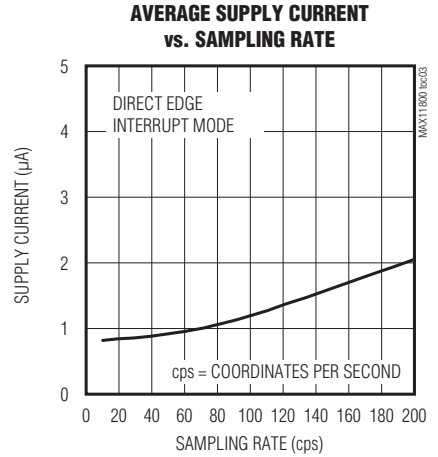
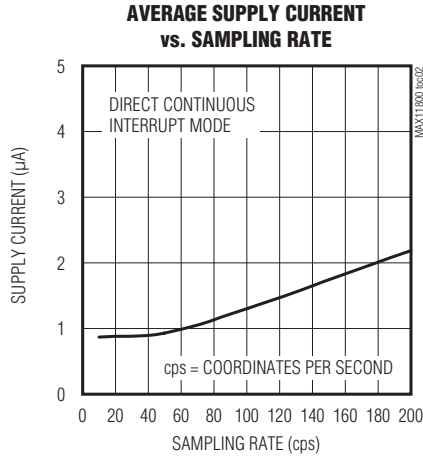
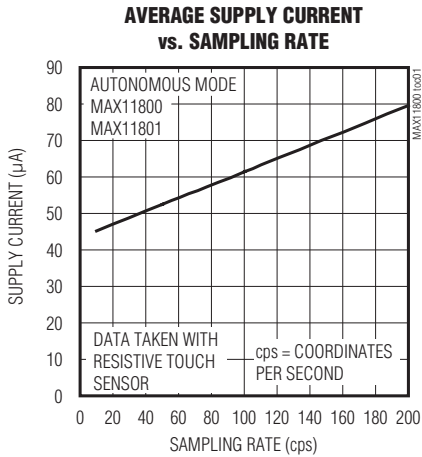

Figure 2. SPI Timing Diagram

Low-Power, Ultra-Small Resistive Touch-Screen Controllers with I²C/SPI Interface

Typical Operating Characteristics

(V_{DD} = 1.8V at T_A = -40°C to +85°C (T_A = -40°C, T_A = 0°C, T_A = +25°C, and T_A = +85°C), 12-bit mode, all measurements using noncontinuous AUX input. SPI = 10MHz and I²C = 400kHz, unless otherwise noted. Resistive touch-screen panel (X+ to X- = 608Ω, Y+ to Y- = 371Ω).)



Low-Power, Ultra-Small Resistive Touch-Screen Controllers with I²C/SPI Interface

MAX11800-MAX11803

Typical Operating Characteristics (continued)

(V_{DD} = 1.8V at T_A = -40°C to +85°C (T_A = -40°C, T_A = 0°C, T_A = +25°C, and T_A = +85°C), 12-bit mode, all measurements using noncontinuous AUX input. SPI = 10MHz and I²C = 400kHz, unless otherwise noted. Resistive touch-screen panel (X+ to X- = 608Ω, Y+ to Y- = 371Ω).)

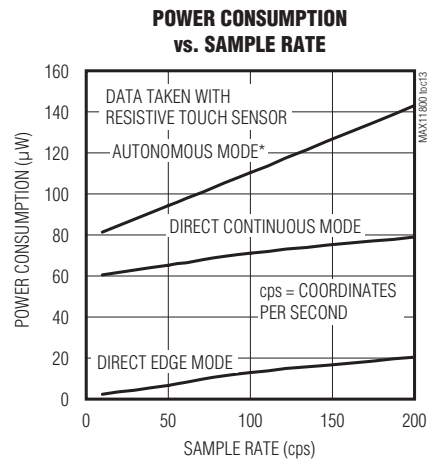
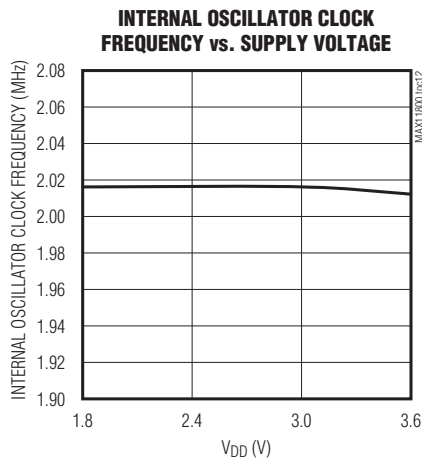
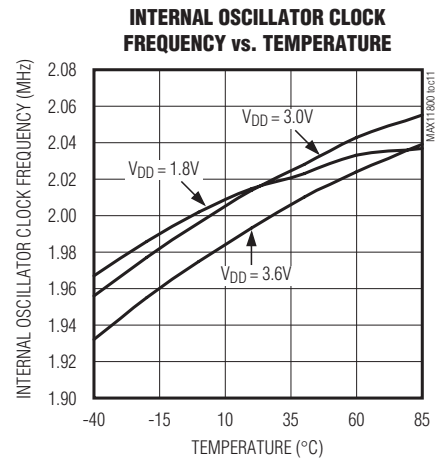
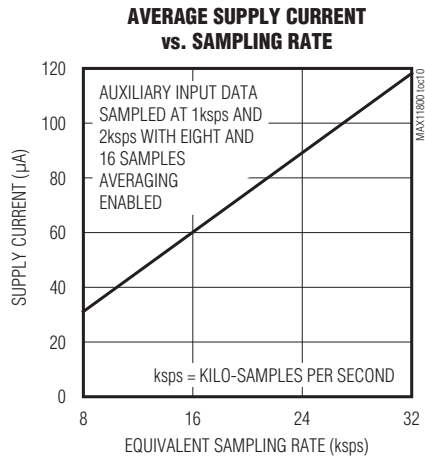
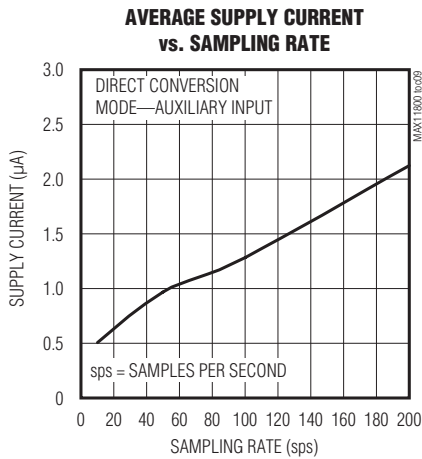

*MAX11800/MAX11801

Low-Power, Ultra-Small Resistive Touch-Screen Controllers with I²C/SPI Interface

Pin Description

PIN				NAME	FUNCTION
MAX11800/MAX11802		MAX11801/MAX11803			
TQFN-EP	WLP	TQFN-EP	WLP		
1	A4	1	A4	X+	X+ Channel Input/Output
2	B4	2	B4	V _{DD}	Power Supply. Bypass V _{DD} to GND with a 1μF capacitor.
3	B3	3	B3	GND	Ground
4	C4	4	C4	X-	X- Channel Input/Output
5	C3	5	C3	Y-	Y- Channel Input/Output
6	C2	6	C2	$\overline{\text{TIRQ}}$	Active-Low Touch Interrupt Output
7	C1	—	—	DIN	SPI Serial Data Input
8	B1	—	—	CLK	SPI Serial Data Clock Input
9	A1	—	—	$\overline{\text{CS}}$	SPI Chip-Select Input
10	B2	—	—	DOUT	SPI Data Output
11	A2	11	A2	AUX	Auxiliary Input
12	A3	12	A3	Y+	Y+ Channel Input/Output
—	—	7	C1	SDA	I ² C Serial Data Bus Input/Output
—	—	8	B1	SCL	I ² C Serial Data Clock Input
—	—	9	A1	A0	I ² C Address Input Bit 0
—	—	10	B2	A1	I ² C Address Input Bit 1
—	—	—	—	EP	Exposed Pad (TQFN only). Connected to ground.

Low-Power, Ultra-Small Resistive Touch-Screen Controllers with I²C/SPI Interface

Functional Diagrams

MAX11800-MAX11803

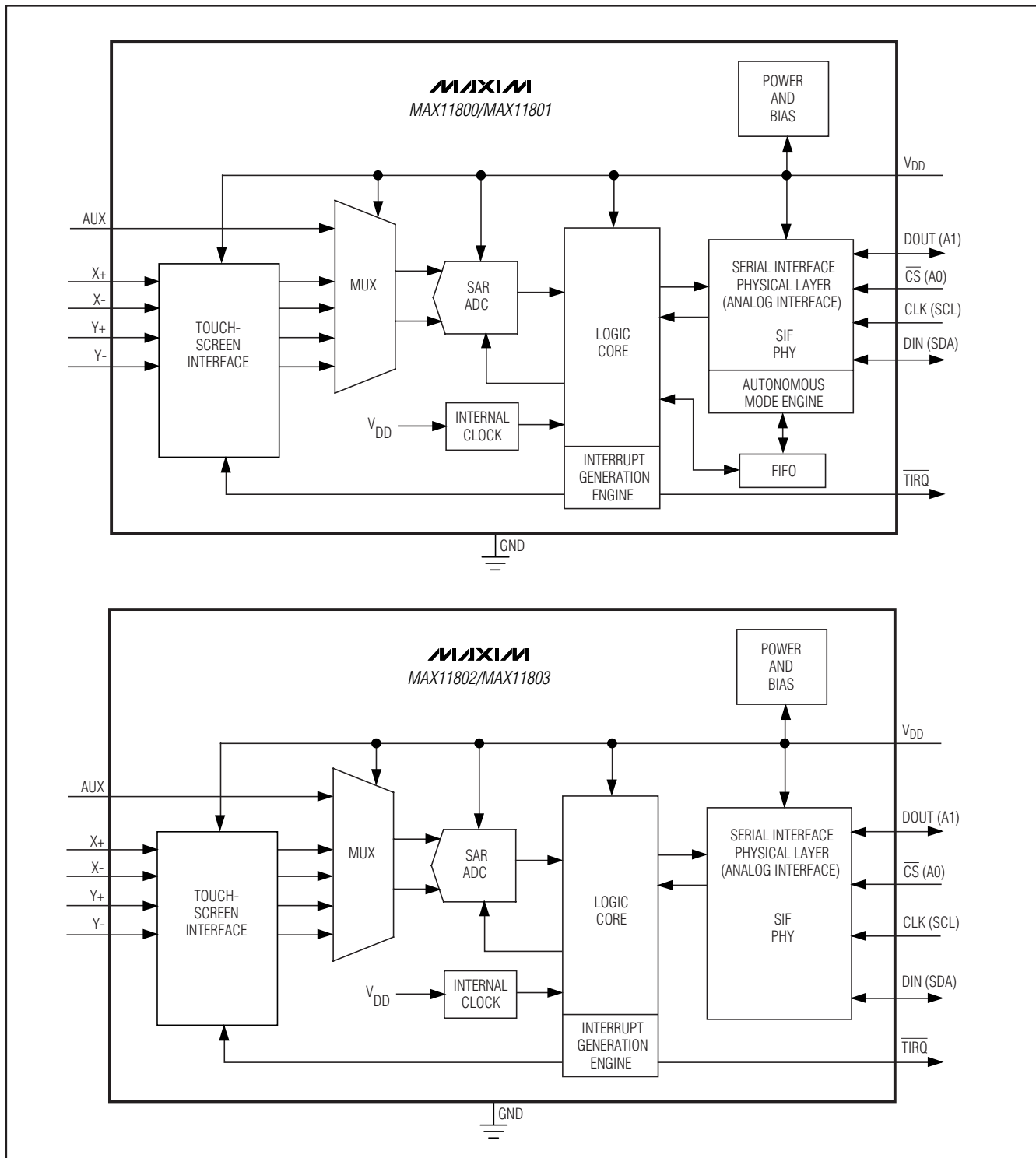

Low-Power, Ultra-Small Resistive Touch-Screen Controllers with I²C/SPI Interface

Detailed Description

The MAX11800–MAX11803 contain standard features found in a typical resistive touch-screen controller as well as advanced features found only on Maxim touch-screen controllers. Standard features included in the MAX11800–MAX11803 are:

- 4-wire touch-screen interface
- X/Y coordinate measurement
- Touch pressure measurement
- Direct conversion operation—requires direct AP involvement
- Single commands—AP initiates all activity, one command at a time
- Ratiometric measurement
- 12-bit SAR ADC
- Single 1.7V to 3.6V supply
- Programmable touch-detect pullup—50k Ω or 100k Ω
- Auto power-down control for low-power operation

Advanced features found in the MAX11800/MAX11801 include:

- Autonomous conversion operation—minimal AP involvement
- On-chip FIFO—buffers up to 16 consecutive measurements
- Data tagging—records measurement and touch-event information
- Filtering—reduces noise using straight or median averaging
- Aperture mode—provides spatial filtering
- Combined commands—multiple operations performed with a single AP command
- User-programmable acquisition modes
- Programmable interrupt output drive

Advanced features found in the MAX11802/MAX11803 include:

- Data tagging—records measurement and touch event information

- Filtering—reduces noise using straight or median averaging
- Combined commands—multiple operations performed with a single AP command
- User-programmable acquisition modes
- Programmable interrupt output drive

The MAX11800/MAX11801 operate in one of two top-level modes: direct conversion mode (DCM) or autonomous conversion mode (ACM). Direct conversion mode requires the AP to initiate all activity to and from the MAX11800/MAX11801. DCM is the operating mode that most standard resistive touch-screen controllers use. ACM allows the MAX11800/MAX11801 to perform measurements automatically and inform the AP when they are complete, reducing data transfers on the serial bus as well as generating fewer interrupt requests. The MAX11802/MAX11803 operate in DCM only. DCM requires the AP to initiate all activity to and from the MAX11802/MAX11803. DCM is the operating mode that most standard resistive touch-screen controllers use.

Both DCM and ACM support averaging, data tagging, and combined commands. Certain commands and operations are only available in DCM, while others are only available in ACM. See Figures 3a and 3b and Table 2 for details.

Position Measurements

Position measurements determine either the X or Y coordinates of the point of contact on the panel sensor. Allow adequate time for the panel to settle when switching between X and Y measurements. Figure 4 shows the physical setup of the panel when performing position measurements.

The element R_{TOUCH} represents the resistance between the X and Y planes of the panel sensor. R_{TOUCH} does not contribute to the error when performing position measurements. R_{TOUCH} affects the panel settling time required between each valid measurement.

The panel end-to-end resistance in the direction of measurement determines the power applied across the panel. The panel dissipates power in the X elements when performing an X direction measurement and dissipates power in the Y elements when performing a Y direction measurement.

Low-Power, Ultra-Small Resistive Touch-Screen Controllers with I²C/SPI Interface

MAX11800-MAX11803

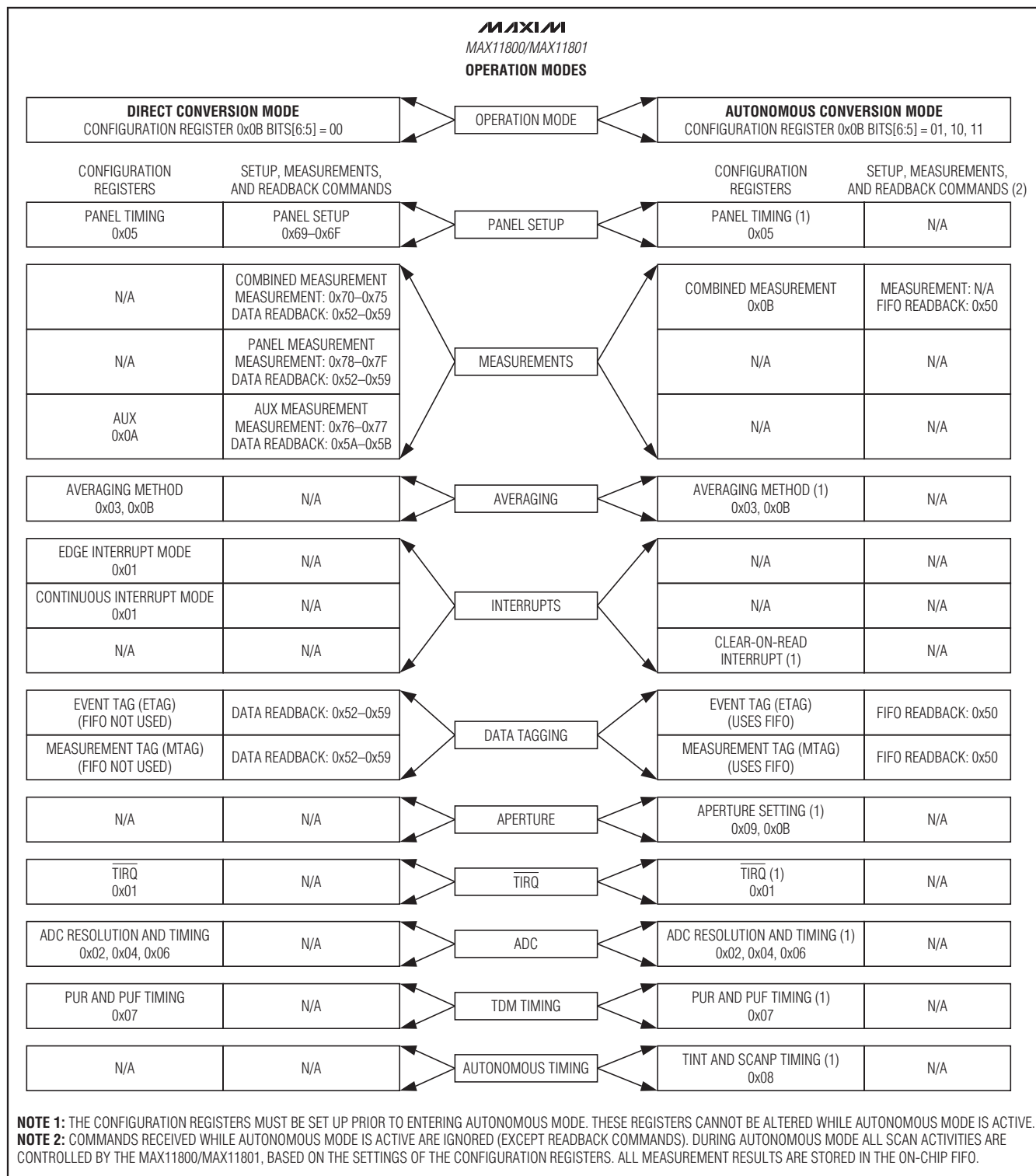

Figure 3a. MAX11800/MAX11801 Operation Modes

Low-Power, Ultra-Small Resistive Touch-Screen Controllers with I²C/SPI Interface

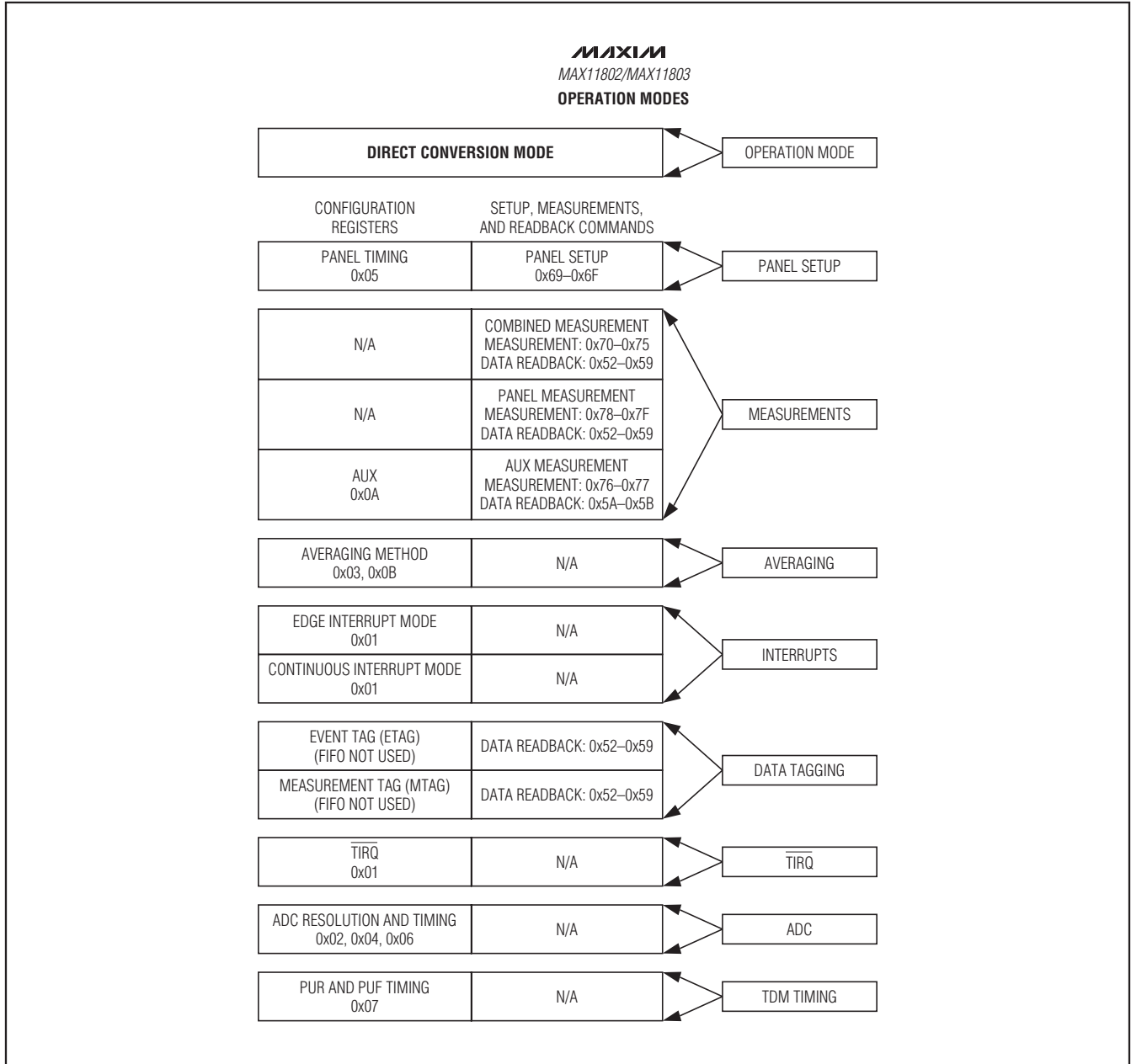

Figure 3b. MAX11802/MAX11803 Operation Modes

Low-Power, Ultra-Small Resistive Touch-Screen Controllers with I²C/SPI Interface

Table 2. Operating Modes, Conditions, and Options

OPERATION MODE	PSU	PMC	CMC	TDM	LPM	AVG	FIFO	APER	PUR PUF	CONT	MTAG	ETAG	X, Y, Z1, Z2	EINT	CINT	COR INT
DCM MAX11800–MAX11803	Yes	Yes	Yes	Yes	No	Yes	No	No	Yes	Yes	Yes ²	Yes ²	Yes	Yes	Yes	No
ACM MAX11800/ MAX11801	Yes ¹	Yes ¹	Yes ¹	Yes	Yes	Yes	Yes	Yes	Yes	No	Yes	Yes	Yes	No	No	Yes
AUX	No	Yes ³	No	No	—	Yes ³	No	No	No	No	No	No	No	No	No	No

¹In ACM, the choices are limited to X and Y scan, or X and Y and Z1 scan, or X and Y and Z1 and Z2 scan.

²In DCM, MTAG is always used. For DCM with CONT = 0, the following ETAGs are used: 00 = touch present (data valid), 10 = no touch present (data may be invalid), 11 = measurement in progress (data invalid). For DCM with CONT = 1, the panel cannot be scanned for a touch because panel setup switches are configured in a measurement mode; therefore, ETAG = 00 is used if a measurement is not in progress, or ETAG = 11 if a measurement is in progress.

³A separate configuration register for delay time, sampling time, averaging, and ADC resolution settings configures the AUX input.

Pressure Measurements

Z1 and Z2 measurements determine the resistance between the two planes within the panel sensor during a touch (R_{TOUCH}). Depending on the known physical properties of the panel, one of two equations extract the value of R_{TOUCH}, providing information about the pressure and area of the touch applied to the panel. Allow adequate time for the panel to settle when switching between position and pressure measurements. Figure 5 shows the physical setup of the panel when performing pressure measurements.

Z1 and Z2 measurements allow observation of the voltage on either side of the effective R_{TOUCH} resistance.

With both Z1 and Z2 measurements available, compute R_{TOUCH} as follows:

$$R_{TOUCH} = R_{XPLATE} \left(\frac{X_{POSITION}}{2^{NBITX}} \right) \left(\frac{Z_2}{Z_1} - 1 \right)$$

If only a Z1 measurement is available, compute R_{TOUCH} as follows:

$$R_{TOUCH} = \left(\frac{R_{XPLATE} X_{POSITION}}{2^{NBITX}} \right) \left(\frac{2^{NBITZ} - 1}{Z_1} \right) - R_{YPLATE} \left(1 - \frac{Y_{POSITION}}{2^{NBITY}} \right)$$

The power applied across the panel during pressure measurements is greatly dependent on R_{TOUCH} and the physical position of the touch. The maximum power dissipation in the panel during a pressure measurement is approximately P_Z = V_{DD}²/R_{TOUCH}. This maximum

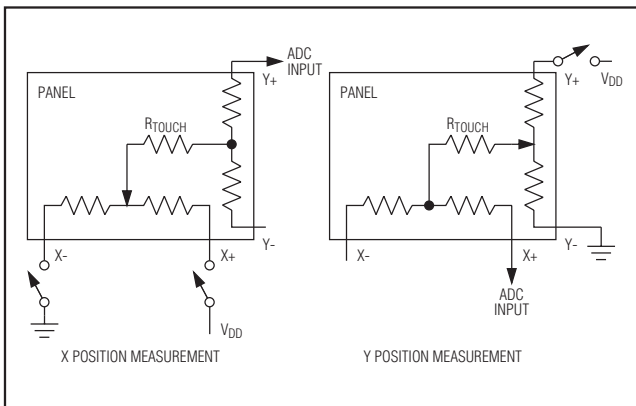

Figure 4. Position Measurements

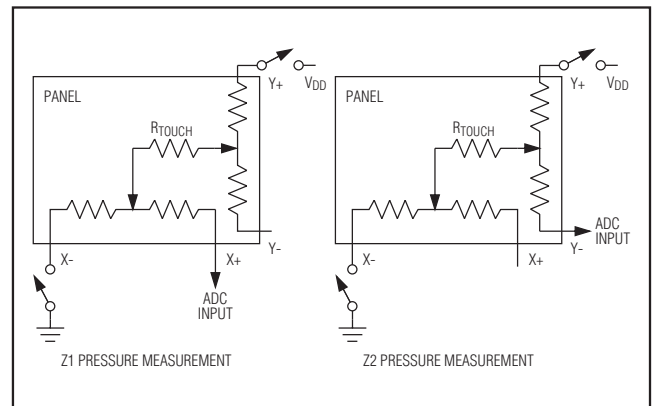

Figure 5. Pressure Measurements

Low-Power, Ultra-Small Resistive Touch-Screen Controllers with I²C/SPI Interface

power dissipation condition is observed when the point of contact is in the top left corner of the panel sensor. The planar end-to-end resistance included in the current path is minimal at this location. Keep the averaging and panel settling durations to the minimum required by the application when pressure measurements are required. Table 3 summarizes the physical panel settings for supported measurement types.

Touch-Detect Modes and Options

Figure 6 shows the internal circuitry in the MAX11800–MAX11803 used to detect the presence of a touch on the panel. The selection of the pullup resistance value (R_{TD} = touch-detect resistance) and the durations of the rough pullup interval (PUR = low-impedance pullup) and fine pullup interval (PUF = high-impedance pullup) are user-defined.

The MAX11800–MAX11803 revert to the low-power panel setup when placed in touch-detect mode (TDM). Figure 6 shows the active panel drive switches (YMSW and XPSW are omitted for simplicity). TSW is a dedicated pullup switch used in TDM. TSW is also used during PUF and TDM. XPSW is activated during PUR periods. TDRSEL allows the selection of an internal pullup resistor value of either 50k Ω or 100k Ω .

The X and Y touch-screen plates create an open circuit with no current flow in the panel when the panel is not being touched. In this case, TOUCH (see Figure 6) is low. When a touch causes contact between the panel X and Y plates, a current path is created and TOUCH is pulled high, as long as $R_{PX} + R_{PY}$ (the sum of panel end-to-end resistance) is much lower than R_{TD} . Typical open-circuit panel plate resistances range from 200 Ω to 1000 Ω .

The MAX11800–MAX11803 enter high-impedance pullup mode (50k Ω or 100k Ω) when the panel is not being touched. The device is idle in this mode until a

touch is detected. The YMSW and TSW transistors are on, and the XPSW and PSW transistors are off. With no touch present, the Y- input of the TSC is at ground and the X+ input is at $V_{DD} - V_{TN}$, where V_{TN} is the threshold voltage of the TSW nMOS device. This is a low-power mode in which no current is consumed until a panel touch occurs. When a touch is present on the panel, the touch-screen controller (TSC) X+ input is pulled low by the touch panel plate resistance and the YMSW transistor. This causes TOUCH to assume a logic-high and the devices either issue the \overline{TIRQ} interrupt for direct conversion modes (MAX11800–MAX11803) or begin self-timed scans for autonomous conversion mode (MAX11800/MAX11801).

The value of the user-defined R_{TD} depends on the characteristics of the panel. To ensure reliable detection values, worst-case panel resistance must be checked against R_{TD} . The interaction between R_{TD} and the panel (or external noise rejecting) capacitance determines how quickly the panel can be switched from measurement modes back to touch monitoring mode without reporting false touches or erroneous tags due to panel settling.

Panel touch status is also required to tag data from a completed scan and measurement operation. Following each scan operation, the panel **must** be returned to TDM to determine if the panel is still being touched and if the data obtained during the scan operation should be considered valid. This operation is required since the panel cannot be monitored for the presence of a touch during the scan and measurement procedure.

The MAX11800–MAX11803 must return to TDM after completing a measurement and making a decision on the touch status of the panel. The measurement procedure is only completed upon resolution of the touch status and when data is tagged and available for readback. The characteristics of the return to TDM and

Table 3. Summary of Physical Panel Settings for Supported Measurement Types

MODE	X+	X-	Y+	Y-	REF+	REF-
X	V_{DD}	GND	ADC_IN	U	X+	X-
Y	ADC_IN	U	V_{DD}	GND	Y+	Y-
Z1	ADC_IN	GND	V_{DD}	U	Y+	X-
Z2	U	GND	V_{DD}	ADC_IN	Y+	X-
PUR	V_{DD} (10 Ω)	U	U	GND	U	—
TDM or PUF	V_{DD} through 50k Ω or 100k Ω	U	U	GND	U	—
LPM	U	U	U	U	U	—

Note: The ADC input is fully differential with the negative input internally connected to GND. The MAX11800–MAX11803 control access to the PUR, PUF, TDM, and LPM, which do not require setup procedures.

U indicates unconnected node.

Low-Power, Ultra-Small Resistive Touch-Screen Controllers with I²C/SPI Interface

the timing of the decision are configurable through the touch-detect pullup timing configuration register (0x07). Program the MAX11800–MAX11803 in the context of the application to maximize power efficiency and achieve the desired scan throughput.

PUR and PUF

PUR is a fast pullup mode, which uses the main X+ switch in parallel with the resistive pullup to quickly slew the panel capacitance. PUF uses only the touch-detect pullup resistor, R_{TD}. PUR and PUF serve the same function as TDM, but are timed so that the panel can settle after completing measurements and before rendering any decisions on the touch status of the panel.

Use the optional PUR mode to reduce the time to tag data by momentarily placing the panel in a low-impedance (< 10Ω) pullup mode instead of using the available 50kΩ/100kΩ touch-detection pullup resistors. This operation forces the monitored TSC input high during the PUR interval. Once the PUR interval expires, a PUF interval must be allowed so that the panel can recover and pull the TSC input low in case a touch is present. The purpose of the PUR mode is to reduce the time required to determine touch status by avoiding long pullup time constants caused by high-capacitance touch panels and the high-impedance on-chip pullup resistors (R_{TD}). When a touch is present during PUR intervals, the current through the low-impedance pullup (XPSW) and panel combination is significantly higher than that observed in the PUF mode. The durations in

the PUR mode should be matched to the panel characteristics and the desired scan throughput rates to minimize power dissipation.

While use of the PUR mode is optional, the PUF period is required for all applications. The PUF interval allows the panel to resettle following scan or optional PUR intervals. When a touch is not present, the panel capacitance settles toward V_{DD} through the internal pullup switch and a portion of the panel resistance (with the optional PUR mode disabled). When a touch is present, the panel capacitance settles toward ground through a portion of the panel resistance, ideally significantly lower than the selected pullup impedance, R_{TD}. Allow enough recovery time for settling through the panel resistance when using a PUR mode. Figure 7 illustrates the touch-detection operations.

Idle Modes

Once the PUF period expires, the preceding measurement data is tagged and made available for readback. The MAX11800–MAX11803 transition to an appropriate mode depending on the conversion and interrupt mode selected.

Features Available in the MAX11800–MAX11803 Averaging Modes

The MAX11800–MAX11803 contain a programmable averaging filter. When enabled, this feature allows collecting 4, 8, or 16 consecutive samples for each measurement type requested. The number of the samples for each measurement type is controlled by configuration register 0x03. Averaging can be assigned to each measurement type. For example, X and Y measurements can use an average of 16 samples, while Z measurements can use one or four samples to save power. The AUX depth is selected in configuration register 0x0A.

The MAX11800–MAX11803 can be configured to perform one of two statistical operations. One option is a median averaging filter (MAF). The MAF first removes the lowest and highest values before averaging the remaining sample set. The second filter type is a straight averaging filter (SAF), which takes the average of the entire sample set. Both filter types and position/pressure averaging are controlled by configuration register 0x0B. Table 4 presents the details of the median averaging operations of the MAX11800–MAX11803. For the MAX11800/MAX11801, averaging is supported in both direct conversion mode and autonomous conversion mode. The MAX11802/MAX11803 support only direct conversion mode.

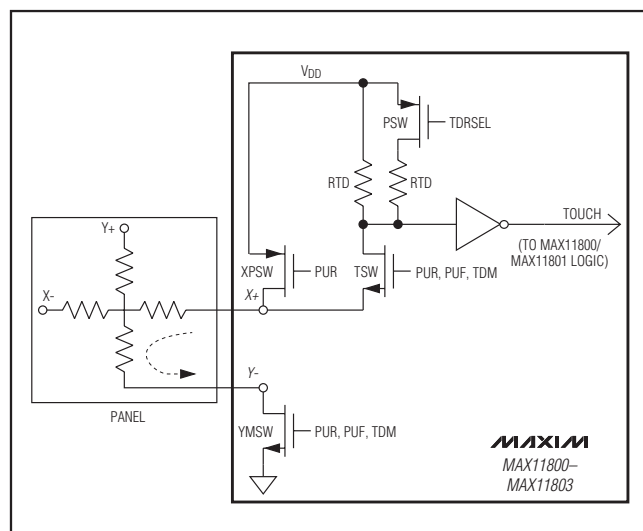

Figure 6. Touch-Detection Circuitry

Low-Power, Ultra-Small Resistive Touch-Screen Controllers with I²C/SPI Interface

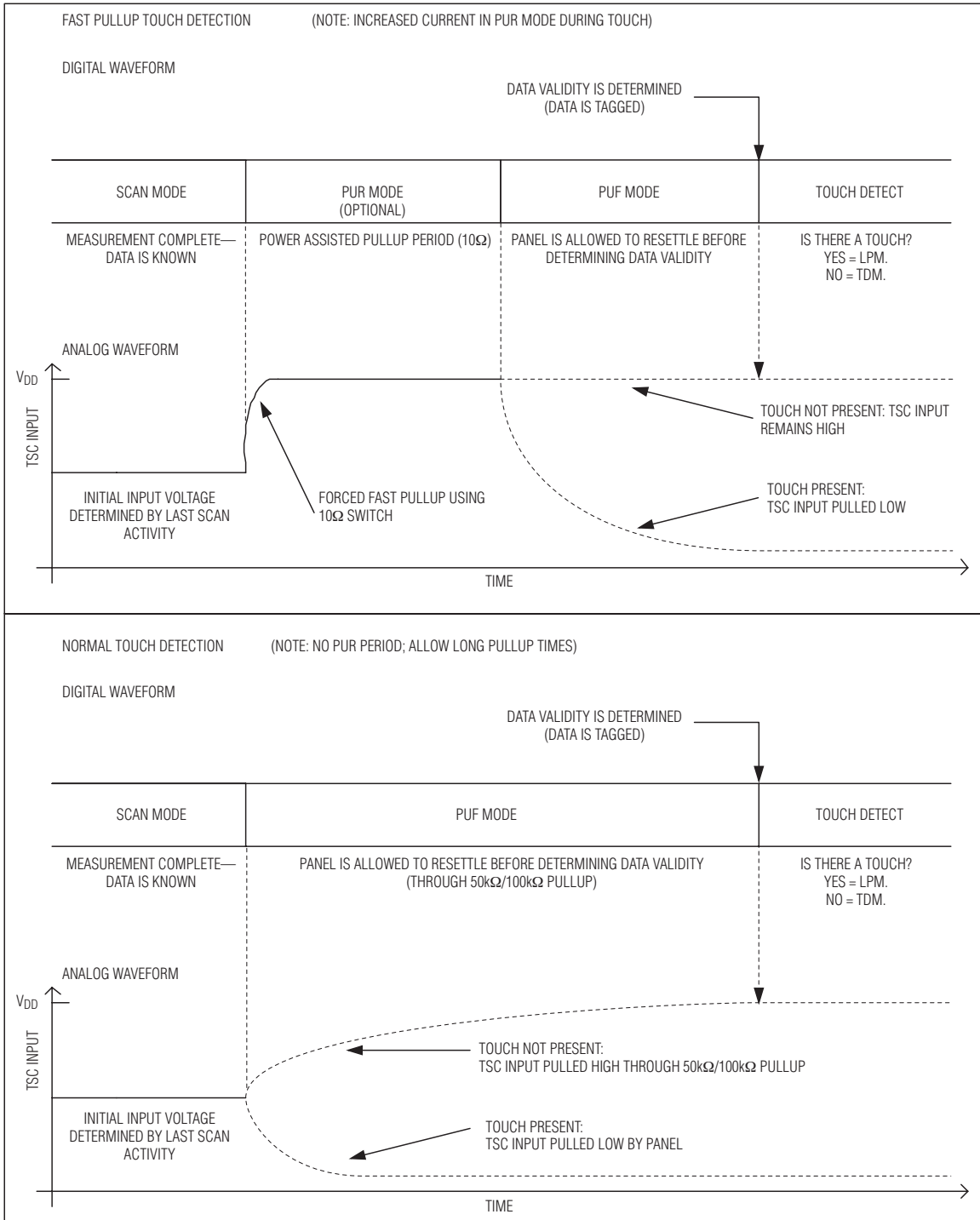

Figure 7. Touch-Detection Operations

Low-Power, Ultra-Small Resistive Touch-Screen Controllers with I²C/SPI Interface

Combined Commands

Combined commands reduce AP interaction with the MAX11800–MAX11803 by allowing multiple measurements. For example, the MAX11800–MAX11803 can be instructed to provide X and Y data, or X and Y and Z1 data, or X and Y and Z1 and Z2 data using a single command.

Data Tagging

In direct conversion modes, all measurement data is contained in a 16-bit word. X, Y, Z1, and Z2 information is stored independently. Each word consists of 12 bits of measurement data plus a 2-bit measurement type (MTAG) and a 2-bit event tag (ETAG). The measurement tag identifies whether the data represents an X, Y, Z1, or Z2 result. The event tag indicates the point at which the data is sampled (initial, midpress, or release) during the touch event. When trying to read a result that is pending, the entire data stream is read back as FFFFh and the event tag as 11b, indicating that the corresponding measurement is in progress and that the data stream is to be ignored. For combined commands, all data locations requested by the command are marked FFFFh, pending the completion of the entire command and the proper tagging of the data. See Table 5.

Direct conversion modes do not use the internal FIFO or support the aperture function (see the *Aperture Modes and Options* section). Each measurement type uses a single location in the (16-bit) memory. The AP must retrieve the data from the last requested measurement before moving on to the next measurement of the type.

Auxiliary measurement data is not tagged because it is not related to panel operation. Auxiliary measurement data is stored and read back identically to the other direct conversion data. The tag locations for auxiliary measurement data are always set to 0000b, unless the read occurs when an auxiliary measurement is in progress. In this situation, the tag locations read 1111b and the data stream reads back FFFFh.

Low-Power Modes

There are also two low-power modes, LPM and TDM. LPM only applies when in DCM with edge interrupt mode or ACM during periods following a conversion where the panel was observed to be touched and a subsequent panel measurement is required and/or scheduled.

During LPM, all circuitry is off, including the on-chip touch-detect pullup resistors used in the touch-detect circuitry. In direct conversion modes, a user-request initiates the next operation and all circuitry is off until a user-command is received. Therefore, the current consumption is primarily due to junction leakage. In autonomous conversion mode, an on-chip oscillator and timer are constantly running. Therefore, the device current consumption is primarily determined by the oscillator and timer.

During TDM, all circuitry is off except the on-chip pullup resistor. This is an untimed mode (oscillator and timer are off) for both ACM and DCM (no digital current). This mode only consumes current through the on-chip pullup resistor when a touch is present. The device can be powered down through register 0x0B when no panel input is expected or needed, and, therefore, no power is consumed through the panel.

Table 4. Median Averaging Operations

AVERAGING MODE	NUMBER OF SAMPLES TAKEN	NUMBER OF HIGH SAMPLES REMOVED	NUMBER OF LOW SAMPLES REMOVED	NUMBER OF REMAINING SAMPLES AVERAGED
1	4	1	1	2
2	8	2	2	4
3	16	4	4	8

Table 5. Data Word Structure (All Direct Conversion Modes)

INDEX	15	14	13	12	11	10	9	8	7	6	5	4	3	2	1	0
Byte	MSB Byte								LSB Byte							
12-Bit Content	Position MSBs								Position LSBs				Measure		Event	
8-Bit Content	Position Data								Trailing Zeros*				Measure		Event	

*When using averaging with 8-bit conversions, these positions may be filled with fractional data due to averaging operations.

Low-Power, Ultra-Small Resistive Touch-Screen Controllers with I²C/SPI Interface

Features Available in the MAX11800/MAX11801 Only

Autonomous Mode

The MAX11800/MAX11801 can perform measurements automatically without the AP involvement, and is referred to as autonomous conversion mode (ACM). When operating in ACM, the MAX11800/MAX11801 use an on-chip FIFO to store measurement results. As each new data is written to the FIFO, an interrupt is generated. The AP can choose to service (read) the FIFO result after each interrupt or wait until the FIFO is full then read the entire FIFO contents at once. The AP can also read the contents of the FIFO at any time. See the *Autonomous Conversion Mode* section for a further description of operations.

Aperture

The MAX11800/MAX11801 contain a feature referred to as aperture. It is only available on the MAX11800/MAX11801 when operating in autonomous conversion mode. The aperture feature creates an invisible rectangle around a touch location within the MAX11800/MAX11801 hardware. The size of the rectangle is user programmable. One application of the aperture feature is to provide “spatial hysteresis.” Spatial hysteresis can be useful for applications that require lower resolution touch accuracy without requiring the AP to handle the mathematics involved to filter out extraneous data. Another application would be to use the aperture feature to implement simple single finger or stylus gestures. See the *Using Aperture Mode* section for a further description of operations.

Panel Setup, Measurement, and Scan Commands

To simplify measurement procedures, the MAX11800–MAX11803 support three types of commands: panel setup commands (PSU), panel measurement commands (PMC), and combined measurement commands (CMC).

In direct conversion mode, the MAX11800/MAX11801 can use all three types of commands. Using individual panel setup and measurement commands allow for a high degree of customization based on decisions made by the AP, while using combined commands significantly simplifies the complete measurement process and reduces communications between the AP and the MAX11800–MAX11803.

In autonomous mode, the MAX11800/MAX11801 use combined commands to control and automate all aspects of panel setup, measurements, and timing. See the *Operating Mode Configuration Register (0x0B)* section for more details.

Direct Conversion Mode Operations

In direct conversion mode, the AP requests individual panel setup and conversion operations or automated combinations of measurements (X and Y, X and Y and Z1, or X and Y and Z1 and Z2 combined). Unlike autonomous conversion modes, the AP maintains control over the initiation of panel setup, measurements events, and the sampling frequency. Figure 8 shows the state machine transitions for direct conversion mode.

Interrupt Modes

The MAX11800–MAX11803 support two direct conversion interrupt modes. The two direct conversion modes are the continuous interrupt mode (CINT) and the edge interrupt mode (EINT).

Continuous Interrupt Mode

In continuous interrupt mode, the panel returns to TDM and idle. The current status of the panel is then sent through $\overline{\text{TIRQ}}$. The continuous interrupt mode is the least efficient mode in current consumption for long duration of touches. The power consumption is approximated by $P_{\text{TOUCH}} = V_{\text{DD}}^2/R_{\text{PU}}$. The power consumption levels observed when the panel is not touched is limited by the junction leakage currents of the MAX11800–MAX11803.

Procedure: The MAX11800–MAX11803 idle in TDM. The $\overline{\text{TIRQ}}$ output goes low when a touch is detected on the panel indicating to the AP that a touch is present and a measurement operation starts.

The AP requests specific panel measurements through the serial interface. $\overline{\text{TIRQ}}$ stays low during panel setup and measurement operations. Once a measurement is complete (with the “continuous” bit, $\text{CONT} = 0$, see Table 1), the MAX11800–MAX11803 check for the continued presence of a touch on the panel and tag the data accordingly (see Table 6). The duration of this operation is programmable, specified in the touch-detect pullup timing configuration register (0x07). After the data is tagged, the data is available for readback through the serial interface. The MAX11800–MAX11803 return to TDM and return control of $\overline{\text{TIRQ}}$ to the TDM circuitry. $\overline{\text{TIRQ}}$ stays low while a touch remains present, indicating further measurements are required, otherwise $\overline{\text{TIRQ}}$ goes high until a new touch is observed.

Continuous interrupt mode (CINT) allows the complete control over the measurement operations and direct observation of the touch status of the panel. Figure 9 shows the polling of $\overline{\text{TIRQ}}$ when other functions share the $\overline{\text{TIRQ}}$ bus. In the illustration of Figure 9, no ‘10’ event tag is observed because the release occurs during a TDM period.

Low-Power, Ultra-Small Resistive Touch-Screen Controllers with I²C/SPI Interface

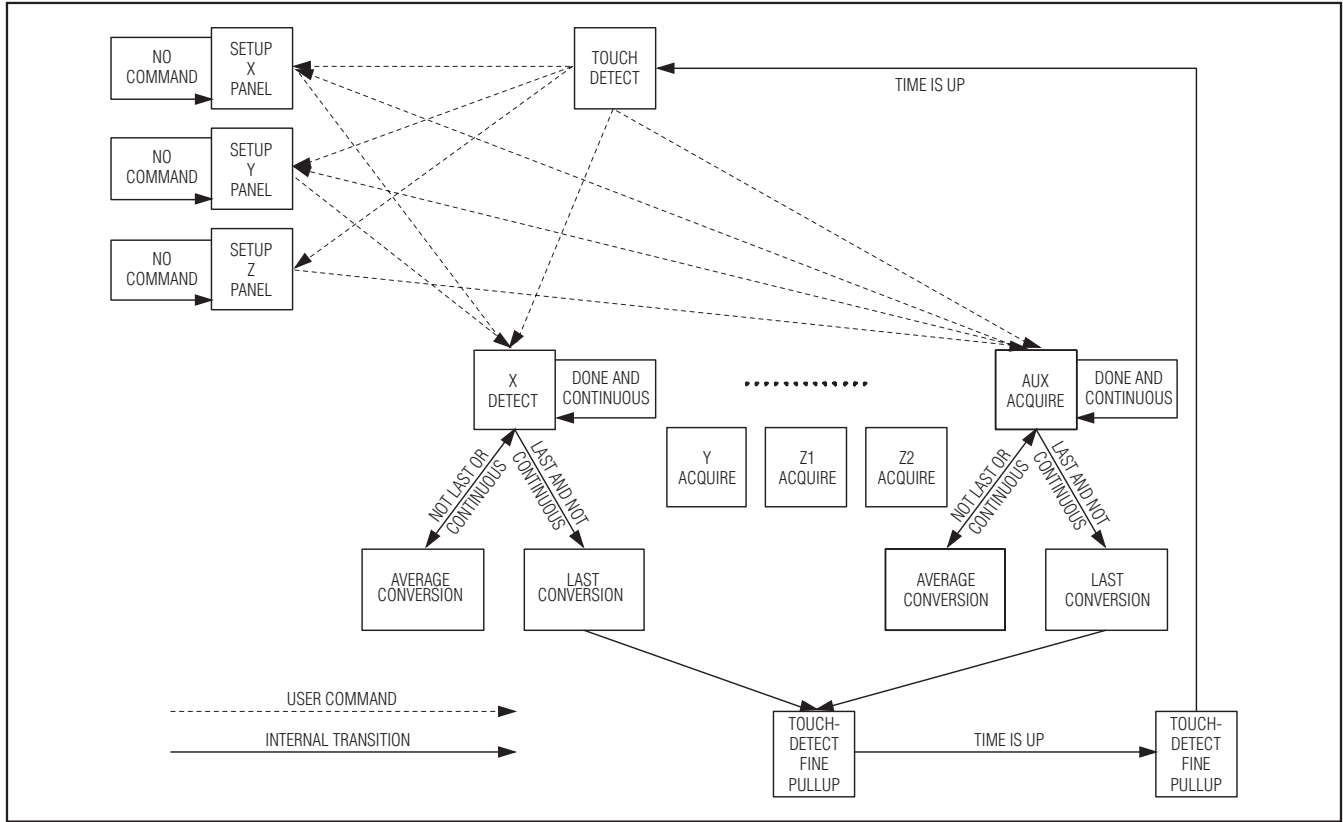

Figure 8. State Machine Transitions (Direct Conversion Mode)—MAX11800–MAX11803

Table 6. Measurement and Event Tags (Continuous Interrupt Mode)

MEASUREMENT	MTAG[3:2]
X	00
Y	01
Z1	10
Z2	11
EVENT	ETAG[1:0]
Touch (data valid)	00
N/A (not used)	01
No touch present (data invalid)	10
Measurement in progress (data invalid)	11

Edge Interrupt Mode

When a touch is present on the panel in edge interrupt mode, the MAX11800–MAX11803 return to an untimed

high-impedance mode once data tagging operations are complete. In edge interrupt mode, the duration of a touch is determined by the tags applied to the measurement data. Data tagged as initial (00) or midpress (01) indicates the user needs to continue to scan the panel until a release is observed. In this state, there is no need to continue monitoring the touch status prior to the next requested measurement. If a panel touch is not present, data is tagged as release (10) and the MAX11800–MAX11803 idle in TDM continuously, issuing an interrupt only when the next panel touch is initiated.

The operation described in the preceding paragraph makes the edge interrupt mode more power-efficient than the continuous interrupt mode. However, the edge interrupt mode requires continuous scanning of the panel until a release (10) event is observed. Otherwise, the MAX11800–MAX11803 do not idle in TDM and are not able to recognize a change in touch status. New touches are not recognized and new interrupts are not issued if a release event is not detected before stopping the conversion sequence.

Low-Power, Ultra-Small Resistive Touch-Screen Controllers with I²C/SPI Interface

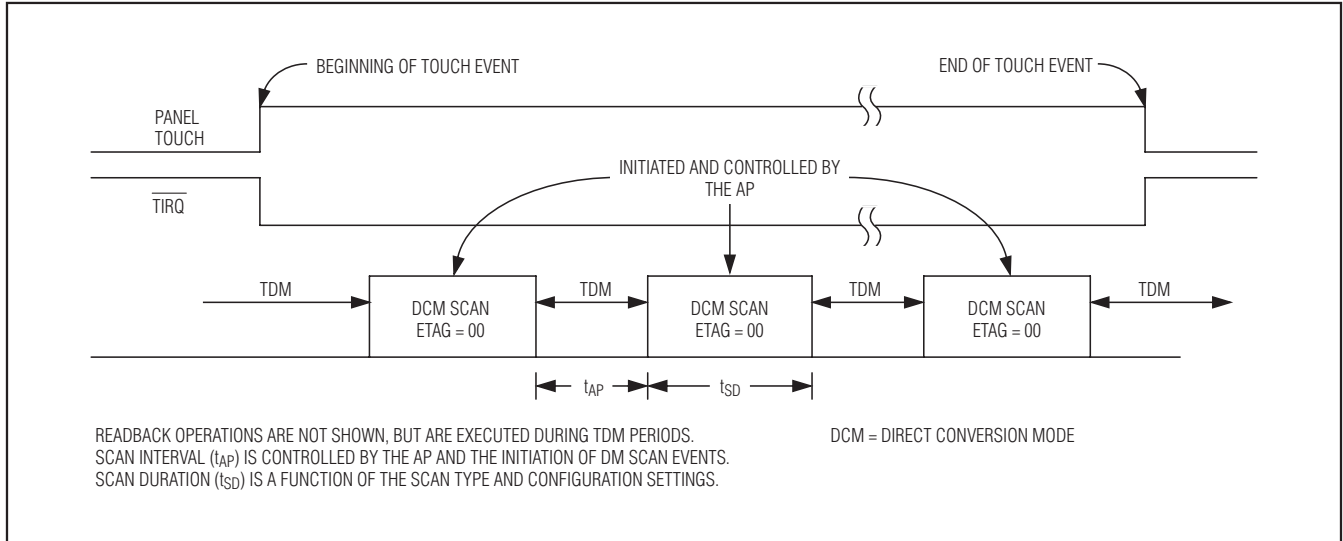

Figure 9. Continuous Interrupt Mode (Direct Conversion Mode)

Procedure: The EINT mode reduces \overline{TIRQ} activity. During EINT, the MAX11800-MAX11803 idle in a TDM. \overline{TIRQ} goes low when a new touch is detected on the panel. \overline{TIRQ} stays low for a fixed duration as specified in the configuration register 0x01, indicating to the AP that a touch is present and measurements are required.

The AP requests specific panel setups and measurements through the serial interface using panel setup and conversion commands after \overline{TIRQ} goes low. Once a measurement is complete (with $CONT = 0$), the MAX11800-MAX11803 check for the continued presence of a touch and tag the data accordingly. See Table 7. The duration of this operation is programmable, specified in the *Touch-Detect Pullup Timing Configuration Register (0x07)* section. After the data is tagged, it is available for readback through the serial interface. The MAX11800-MAX11803 do not return to TDM when the panel touch is still present ($ETAG = 00, 01$), but remain in an LPM awaiting further measurement commands. The devices return to TDM when the panel touch is no longer present ($ETAG = 10$) and return control of the \overline{TIRQ} interrupt to the TDM circuitry to await the next touch event.

After a touch is indicated, the AP must continue to issue conversion commands until the touch is removed, alerting the AP when the panel is released (by $ETAG = 10$). The MAX11800-MAX11803 return to TDM and observe the start of the next touch event. Panel commands

issued with $CONT = 1$ are not capable of fulfilling this requirement.

The EINT mode provides the least interrupt activity and the lowest power consumption. Use EINT mode for general touch-screen applications and applications requiring high resolution in space and time. When the \overline{TIRQ} bus is shared with other functions, poll the general status register (0x00) to detect the presence of an interrupt. See Figure 10.

Table 7. Measurement and Event Tags (Edge Interrupt Mode)

MEASUREMENT	MTAG[3:2]
X	00
Y	01
Z1	10
Z2	11
EVENT	
EVENT	ETAG[1:0]
Initial touch (data valid)	00
Midpress (data valid)	01
Release/no touch present (data invalid)	10
Measurement in progress (data invalid)	11

Low-Power, Ultra-Small Resistive Touch-Screen Controllers with I²C/SPI Interface

MAX11800–MAX11803

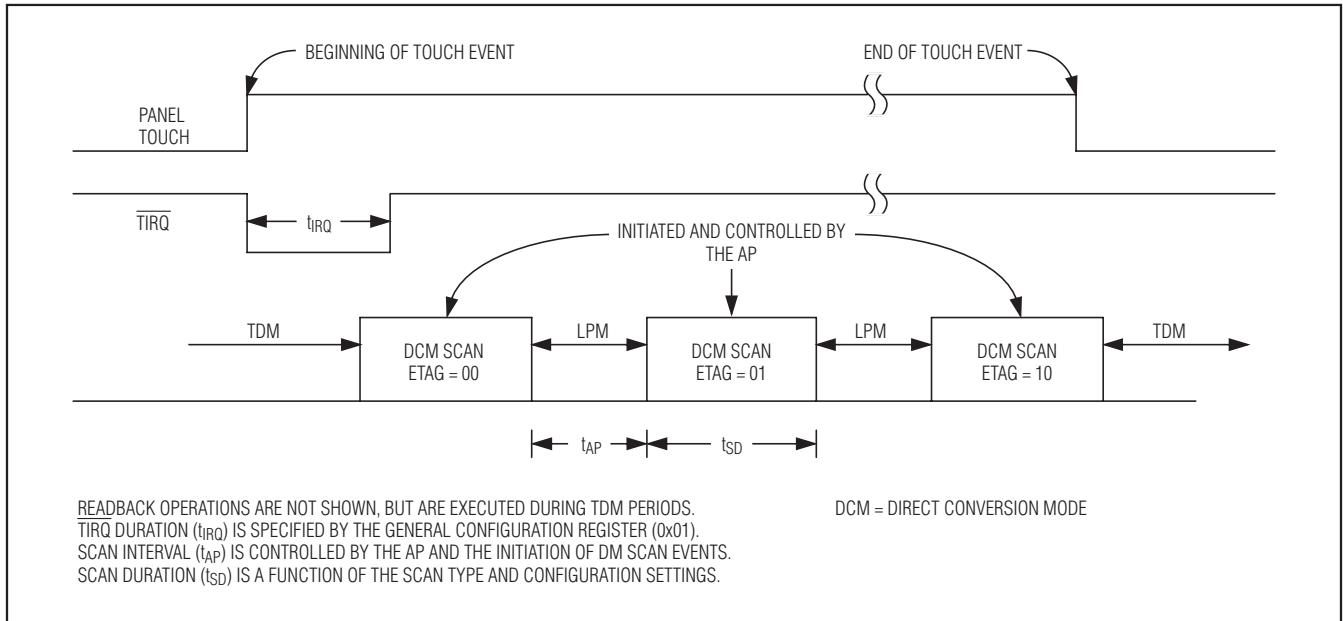

Figure 10. Edge Interrupt Mode (Direct Conversion Mode)—MAX11800–MAX11803

Table 8. Panel Setup Command Summary

HEX	ACCESS	PAIRABLE	COMMAND LENGTH	OPERATION
0x69h	Write	No	8	X = panel setup
0x6Bh	Write	No	8	Y = panel setup
0x6Dh	Write	No	8	Z1 = panel setup
0x6Fh	Write	No	8	Z2 = panel setup

Panel Setup Commands

Panel setup commands configure the touch panel prior to a measurement. Panel setup commands allow the panel to fully settle before performing a measurement. The panel setup command summary is shown in Table 8. See the register map in the *Status and Configuration Registers* section for details on the panel setup timing options for X, Y, Z1, and Z2 measurements.

The continuation bit (CONT) of the panel setup command programs the MAX11800–MAX11803 to maintain the present panel setting at the end of the command (CONT = 1). Panel setup commands assume a logical progression to an appropriate measurement. For example, when the MAX11800–MAX11803 are in the X panel setup mode, the devices can proceed to an X measurement mode only. The devices return to LPM when an incompatible command follows a panel setup command. See Figure 11. For most applications adequate time for panel setup is available as an integral part of

the panel measurement commands; configured using the panel setup timing configuration register, 0x05. The dedicated panel setup commands are primarily provided to support applications where the AP needs to control panel setup directly or long panel setup time is required.

Panel Measurement Commands

A measurement command selects one of the four physical setup options: X, Y, Z1, or Z2.

All panel measurement commands include timed intervals to power up both the internal ADC and the panel with programmable durations. The delayed conversion time (t_{D_CV} , delayed conversion configuration register (0x06)) governs the time that the panel and the ADC need to settle prior to the initiations of conversions. The minimum delayed conversion time is 10 μ s, which is the time the internal ADC needs to power up. If more settling time is required, increase the panel settling time

Low-Power, Ultra-Small Resistive Touch-Screen Controllers with I²C/SPI Interface

Table 9. Panel Measurement Command Summary

HEX	ACCESS	PAIRABLE	COMMAND LENGTH	FUNCTION
0x70h	Write	No	8	X, Y = combined command measurement
0x72h	Write	No	8	X, Y, Z1 = combined command measurement
0x74h	Write	No	8	X, Y, Z1, Z2 = combined command measurement
0x76h	Write	No	8	AUX = conversion
0x78h	Write	No	8	X = measurement, CONT = 0
0x79h	Write	No	8	X = measurement, CONT = 1
0x7Ah	Write	No	8	Y = measurement, CONT = 0
0x7Bh	Write	No	8	Y = measurement, CONT = 1
0x7Ch	Write	No	8	Z1 = measurement, CONT = 0
0x7Dh	Write	No	8	Z1 = measurement, CONT = 1
0x7Eh	Write	No	8	Z2 = measurement, CONT = 0
0x7Fh	Write	No	8	Z2 = measurement, CONT = 1

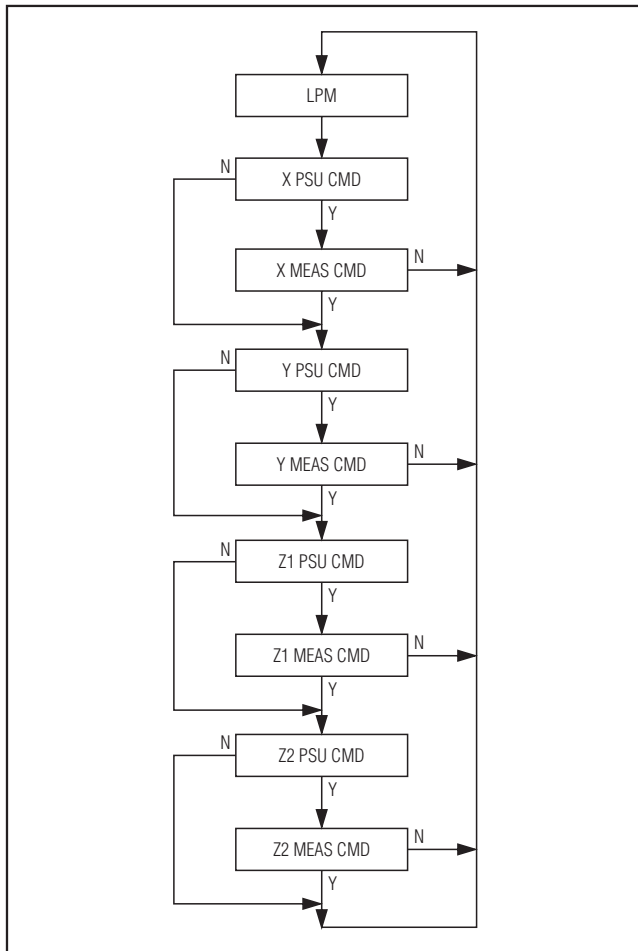

Figure 11. Command and Measurement Flow (DCM)

by delaying the conversion time or by adding an additional panel setup time (t_{PSU}) using the panel setup timing configuration register (0x05). The advantage of using a dedicated panel setup time is that the ADC does not consume power during this interval. The required panel setup time is a function of the panel end-to-end resistance, the capacitance of the panel, and any board-level components.

When using a measurement command with CONT = 1 in a direct conversion mode, the devices remain in the requested setup mode in preparation for the succeeding measurement. The panel does not return to TDM/LPM and the interrupt status is not modified as a result of a measurement command with CONT = 1 issued. See Figure 12.

Combined Commands

In direct conversion modes, the panel returns to a TDM at the conclusion of a combined command and all data are tagged accordingly. The MAX11800-MAX11803 then idle in a low-power mode determined by the interrupt mode selected. See Figure 13.

Auxiliary Measurement Command

The MAX11800-MAX11803 support measurement of an auxiliary input using the internal ADC in direct conversion mode only. When programmed, the devices sample and quantize the voltage at AUX using V_{DD} as the ADC reference. The MAX11800-MAX11803 store the result in the same manner as X, Y, Z1, and Z2 measurements, but do not add data tagging. The devices also support averaging functions. Auxiliary measurements do not require any panel setup procedure. There is no

Low-Power, Ultra-Small Resistive Touch-Screen Controllers with I²C/SPI Interface

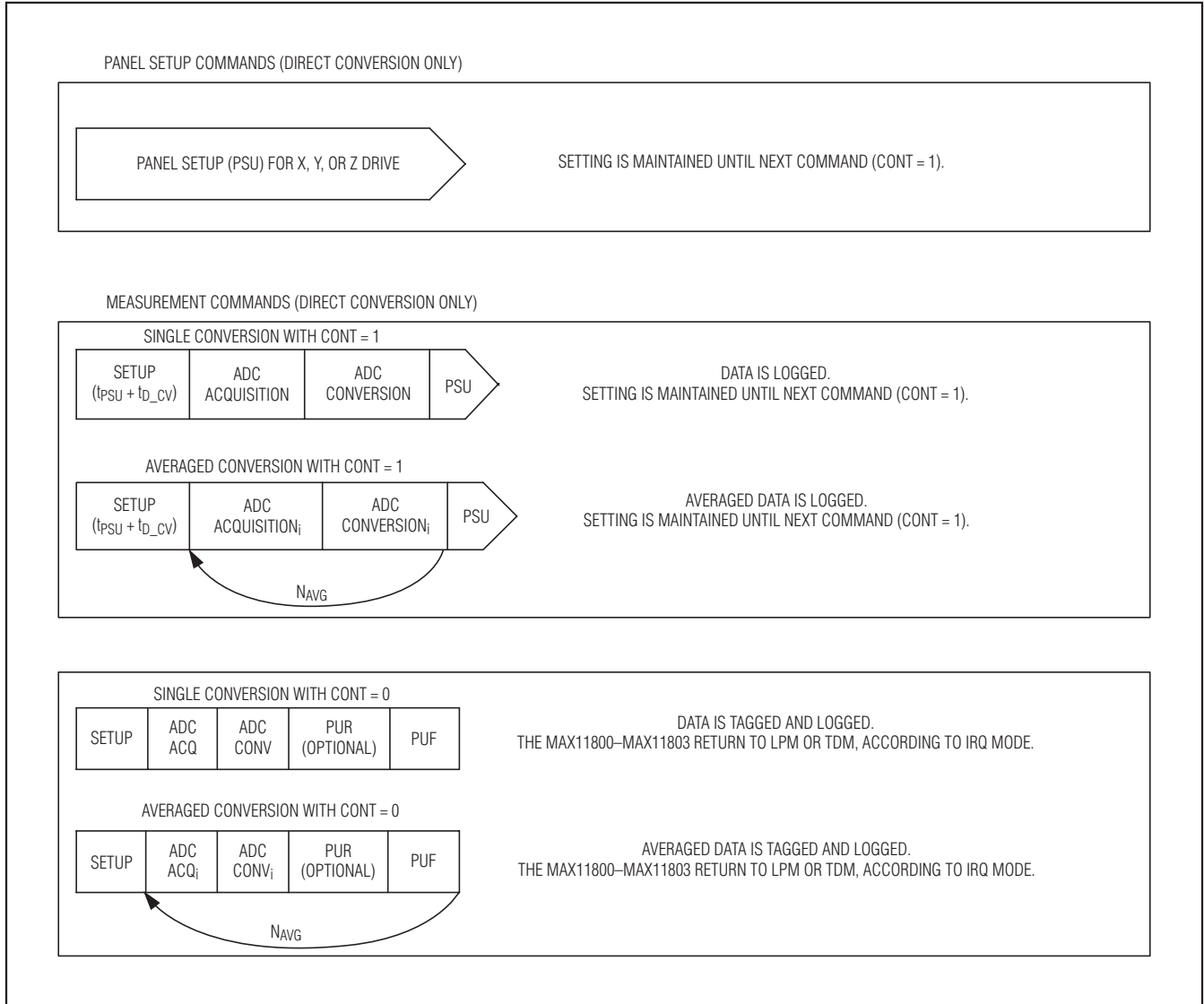

Figure 12. Panel Setup and Measurement Commands—MAX11800–MAX11803

combined command which includes an auxiliary measurement. Register 0x0A specifies the configuration for auxiliary measurements.

In CINT, the MAX11800–MAX11803 continue to monitor for the touch status of the panel. The devices report any change in touch status in real time during an auxiliary measurement procedure.

When performing auxiliary measurements in edge interrupt mode, the MAX11800–MAX11803 temporarily suspend the panel touch monitoring. The devices notify the AP after the completion of the auxiliary measurement when a new touch occurs during the auxiliary measurement.

Low-Power, Ultra-Small Resistive Touch-Screen Controllers with I²C/SPI Interface

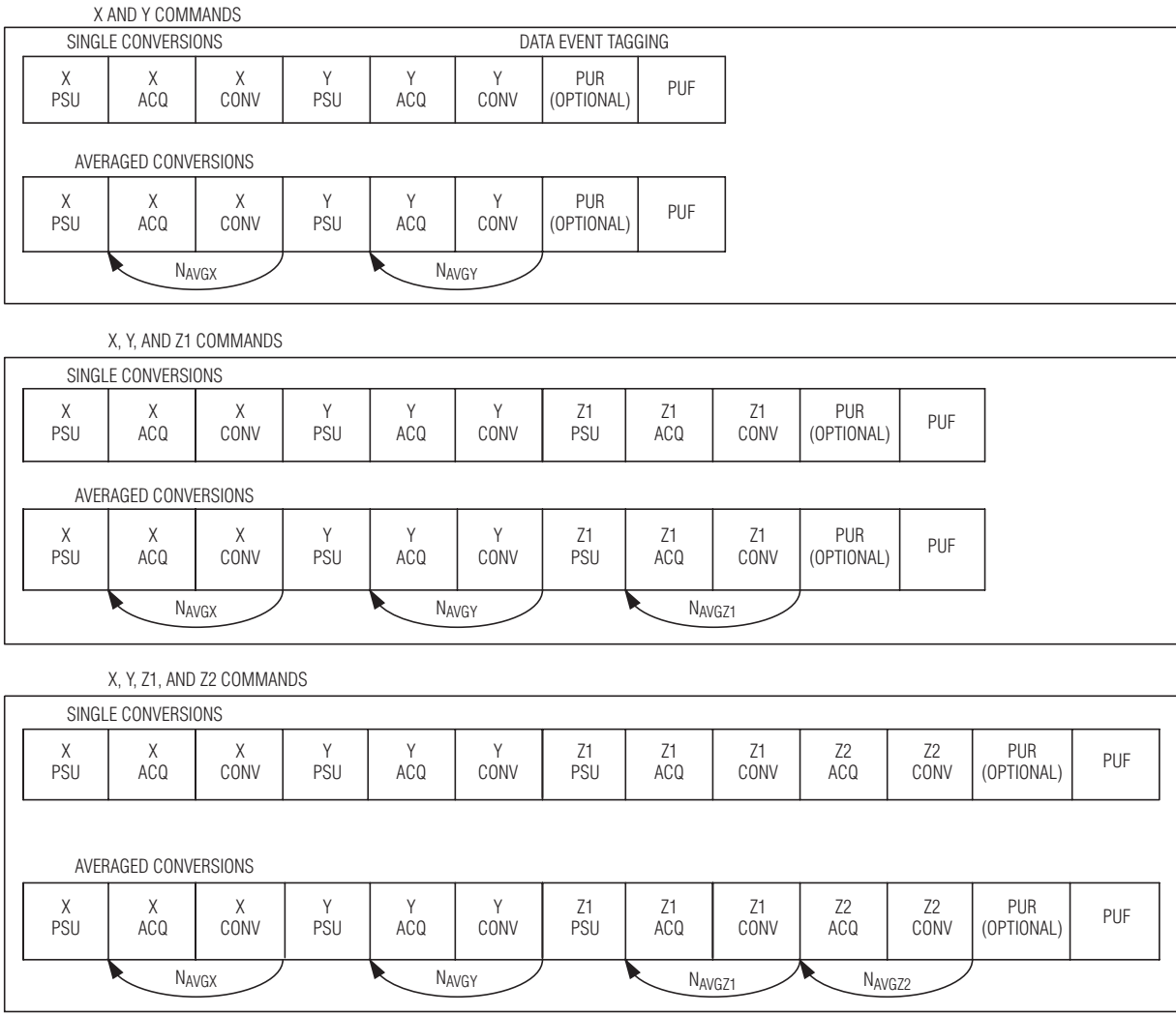

Figure 13. Combined Commands—MAX11800-MAX11803

Low-Power, Ultra-Small Resistive Touch-Screen Controllers with I²C/SPI Interface

Autonomous Conversion Mode

The MAX11800/MAX11801 perform measurements automatically and inform the AP when they are complete in autonomous conversion mode, reducing data

transfers on the serial bus as well as generating fewer interrupt requests. Figure 14 shows the state machine transitions for autonomous conversion mode.

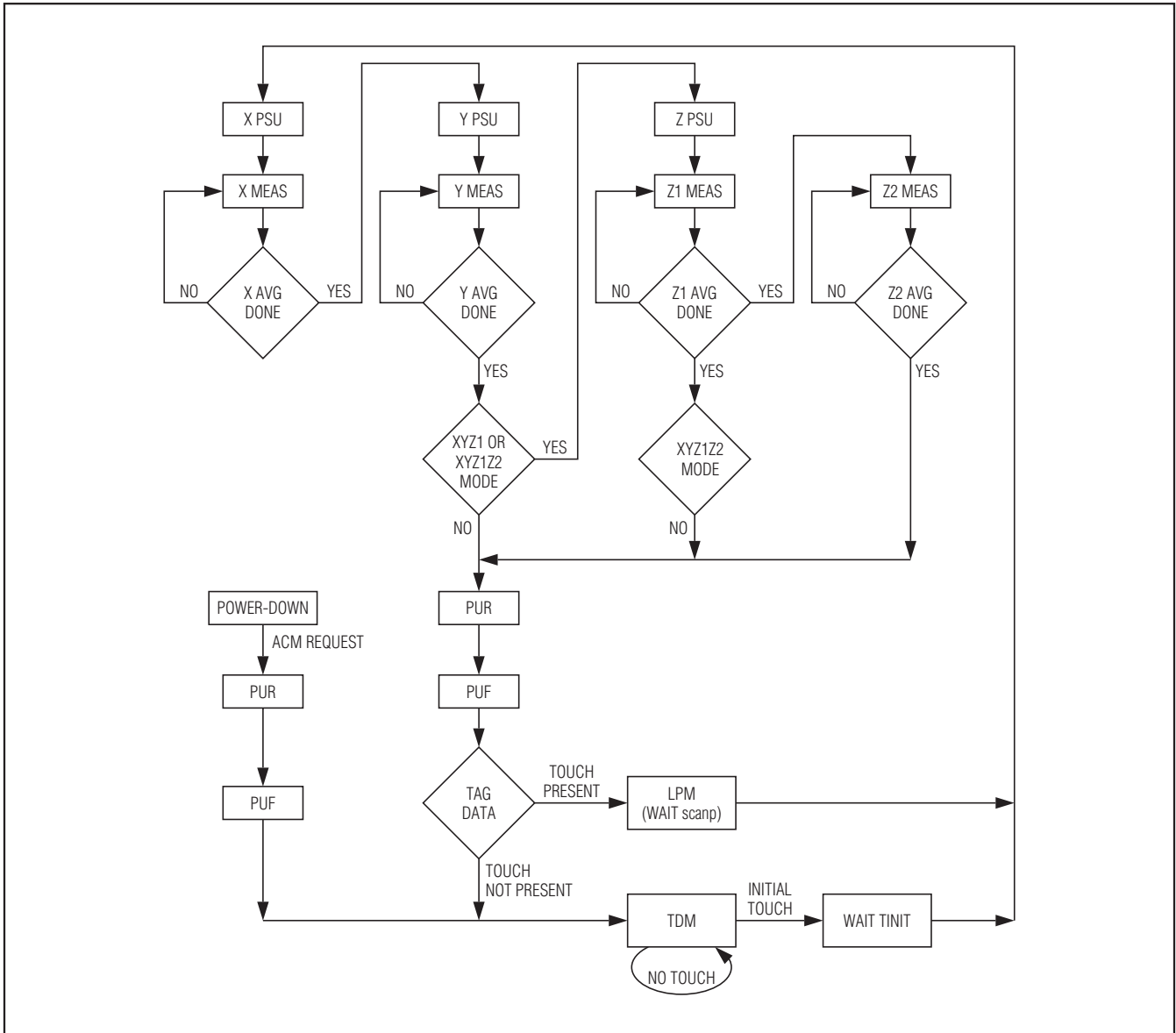

Figure 14. State Machine Transitions—Autonomous Conversion Mode—MAX11800/MAX11801

Low-Power, Ultra-Small Resistive Touch-Screen Controllers with I²C/SPI Interface

Measurement Operations

In autonomous conversion, the MAX11800/MAX11801 idle in TDM until a touch event occurs. The MAX11800/MAX11801 begin an automated sequence of measurements as defined by the configuration register 0x08h.

The MAX11800/MAX11801 tag and log the data into the FIFO once a measurement is taken. If a touch is still present, the devices continue to idle in a LPM until the time, as set by the configuration settings, expires. If no touch is present at the expiration of the time set by the configuration settings, the MAX11800/MAX11801 return to TDM to await the next panel touch.

All measurement operations occur without any intervention from the AP. The MAX11800/MAX11801 issue interrupts when new data is available in the internal FIFO. The device clears the interrupt when all data is read back. The AP controls the readback of measurement data as the data becomes available.

Combined Commands

In autonomous conversion mode, the MAX11800/MAX11801 automatically perform the combined command defined in the configuration register. The devices continuously scan for panel touch events. Between scans, the devices idle in a low-power mode according to the present touch status.

Clear-on-Read Interrupt Mode

The MAX11800/MAX11801 control the progression through modes in clear-on-read mode. When the panel touch is present, the MAX11800/MAX11801 return to a

timed high-impedance LPM to minimize current, after the data tagging operations are complete. The MAX11800/MAX11801 idle in LPM until it is time to perform the next required scan, determined by the configuration register settings. When a touch is not present at the end of a measurement, the device returns to idle in TDM. In TDM, the device waits until a touch is detected before initiating another set of autonomous measurements.

The MAX11800/MAX11801 adopt a clear-on-interrupt protocol (CORINT) when in autonomous conversion mode. Between touch events, the devices idle in a low-power TDM state. Upon detection of a touch, the devices begin a sequence of automated measurements. Each time a qualifying measurement is completed, the data for that measurement is written to the internal FIFO. Qualifying measurements are measurements that indicate the beginning and end of a touch event, which meet aperture requirements (see the *Aperture Range Requirements* section).

\overline{TIRQ} issues an interrupt once a qualifying measurement is completed and logged into the FIFO indicating that new data is available for the AP to read back. The MAX11800/MAX11801 continue to perform measurements as required by the configuration settings. Program the AP to service the interrupt immediately to avoid a FIFO overflow and loss of data. \overline{TIRQ} remains asserted until all unread FIFO data has been read back to the AP. The AP confirms that readback is complete either by monitoring \overline{TIRQ} or by monitoring the data event tags embedded in the data for end-of-FIFO. (ETAG = 11b). See Figure 15.

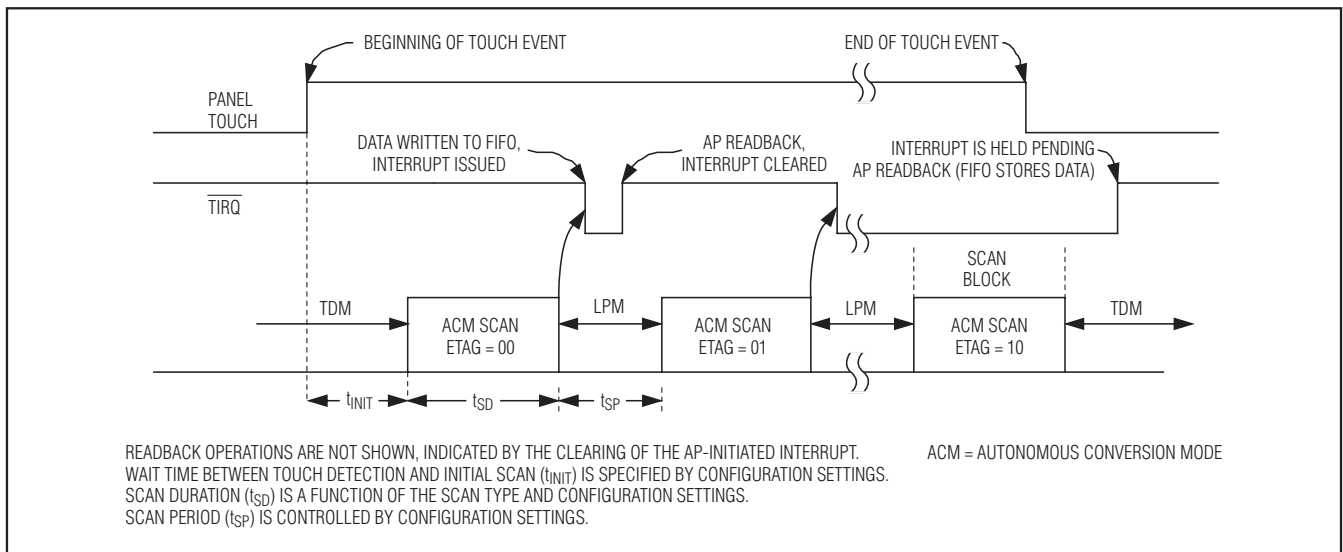

Figure 15. Clear-on-Read Interrupt Operation—MAX11800/MAX11801

Low-Power, Ultra-Small Resistive Touch-Screen Controllers with I²C/SPI Interface

Delayed Touch Detection During Mode Transitions

The MAX11800/MAX11801 support a low-power power-down mode suspending all touch-screen activity and the panel is not driven. In this mode, the MAX11800/MAX11801 is unable to detect a touch. When commanded to transition from PWRDN to any normal mode of operation, the MAX11800/MAX11801 go through a PUR/PUF sequence prior to observing the panel touch status, minimizing the occurrence of interrupts issued by false touches caused by the initial state of panel capacitances.

In addition, when commanded to transition between normal operating modes, the MAX11800/MAX11801 clear any existing interrupts and go through the PUR/PUF sequence prior to observing the current panel touch status.

FIFO Memory

The MAX11800/MAX11801 include an internal FIFO to store scan block results for readback through the AP. Each scan block result contains complete data for all measurements requested by the scan type (X, Y; or X, Y, Z1; or X, Y, Z1, Z2). The depth of each scan data block ranges from 32 bits (X, Y mode) to 48 bits (X, Y, Z1 mode) or 64 bits (X, Y, Z1, and Z2 mode).

The internal FIFO stores up to 16 complete scan blocks, a total of 1024 bits. Regularly service the FIFO to prevent overflow conditions. In the event of an overflow, the FIFO ceases to write new data until the old data is read or cleared. Avoid overflow to prevent data loss and unreliable behavior.

Check the general status register (0x00) and the FIFO overflow bit to determine if the FIFO is in overflow. The FIFO overflow bit asserts when a data overflow occurs. See the *Clearing FIFO* section.

Clearing FIFO

Write to the operating mode configuration register (0x0B) to clear the FIFO. Modifying the contents of the register is not necessary as any write operation to this register location clears the FIFO and the interrupt \overline{TIRQ} (if present).

The FIFO completely clears when autonomous conversions halt and the MAX11800/MAX11801 transition to direct conversion mode. The FIFO also clears on transitions from direct conversion mode to autonomous mode.

FIFO Data Block Readback Structure

Table 10 illustrates the scan data block structure within the FIFO for each scan type. Block boundaries are indicated by bold lines. Numeric subscripts denote the sample order when the data was taken. Readback proceeds from top to bottom. FIFO blocks are written as a complete unit with an interrupt issued only after all required block measurements are complete and data is tagged. A FIFO data block consists of 2, 3, or 4 FIFO data words (word = 16 bits).

Table 10. FIFO Data Block Structure

2-WORD BLOCK (X, Y)	3-WORD BLOCK (X, Y, Z1)	4-WORD BLOCK (X, Y, Z1, Z2)
X ₁ MSB	X ₁ MSB	X ₁ MSB
X ₁ LSB	X ₁ LSB	X ₁ LSB
Y ₁ MSB	Y ₁ MSB	Y ₁ MSB
Y ₁ LSB	Y ₁ LSB	Y ₁ LSB
X ₂ MSB	Z ₁ MSB	Z ₁ MSB
X ₂ LSB	Z ₁ LSB	Z ₁ LSB
Y ₂ MSB	X ₂ MSB	Z ₂ MSB
Y ₂ LSB	X ₂ LSB	Z ₂ LSB
X ₃ MSB	Y ₂ MSB	X ₂ MSB
X ₃ LSB	Y ₂ LSB	X ₂ LSB
Y ₃ MSB	Z ₂ MSB	Y ₂ MSB
Y ₃ LSB	Z ₂ LSB	Y ₂ LSB
X ₄ MSB	.	Z ₁ MSB
X ₄ LSB	.	Z ₁ LSB
Y ₄ MSB	.	Z ₂ MSB
Y ₄ LSB	.	Z ₂ LSB

Low-Power, Ultra-Small Resistive Touch-Screen Controllers with I²C/SPI Interface

FIFO Data Word Structure

Table 11 shows a 16-bit data word (MSB byte + LSB byte). Each data word consists of 12 bits of position data, mapped to locations [15:4]. Eight-bit measurement data are left-adjusted and mapped to locations [15:8] and followed by four trailing zeros if averaging is off. If averaging is on, the 4 bits contain random data as a result of the summation and division process. Table 12 shows a 2-bit measurement tag indicating the measurement type (X, Y, Z1, or Z2), appended in locations [3:2]. Table 13 shows a 2-bit event tag indicating where the sample occurs within a touch event (initial, midpress, or release) in locations [1:0].

All data for a given scan operation is tagged according to the touch status observed at the end of the scan block measurement operations. For example, if a requested X, Y, Z1, Z2 scan block contains a release event, all the data words are tagged 10 before being written to the FIFO.

An event tag of 11 indicates that the data readback operation reaches the end of the current FIFO data log (end of file marker) and there is no unread data in the FIFO. Terminate the readback operation to await the next interrupt. Ignore all data with the 11 event tag.

Block Readback Operations

The MAX11800/MAX11801 do not support partial block readback operations. Each readback operation loads an entire scan block result (32, 48, or 64 bits) into a temporary location for serial readback. A scan block is marked as read in the FIFO once a scan block result is loaded, freeing the memory space for the subsequent measurements. Once initiated, the AP must complete the full readback cycle for the block requested or the unread portions of the block data is lost.

Table 11. FIFO Data Word Structure

INDEX	15	14	13	12	11	10	9	8	7	6	5	4	3	2	1	0
Byte	MSB Byte								LSB Byte							
12-Bit Content	Position MSBs								Position LSBs				Measure		Event	
8-Bit Content	Position Data								Trailing Zeros*				Measure		Event	

*When using averaging with 8-bit conversions, these positions may be filled with fractional data due to averaging operations.

Table 12. FIFO Data Measurement Tags

MEASUREMENT	TAG[3:2]
X	00
Y	01
Z1	10
Z2	11

Clearing Interrupt

The FIFO is only used in the autonomous mode with the clear-on-read interrupt. The interrupt is cleared only when the newest data block currently available in the FIFO is loaded for readback. The interrupt does not clear if there is any unread data block remaining in the FIFO once a scan block result is loaded. The FIFO does not check for partial block readbacks. Once the last available FIFO data block is loaded for readback, the interrupt clears regardless of whether the readback operation for that block is complete.

Aperture Modes and Options

The aperture modes available with the MAX11800/MAX11801 implement spatial filtering. The MAX11800/MAX11801 contain the required logic to examine panel measurement data and determine if the data meets the aperture requirements to be written to the FIFO. Aperture testing decreases the number of entries in the FIFO to the minimum required to implement the intended application. The elimination of extraneous FIFO data events reduces activity on the TIRQ line, serial bus, and minimizes AP overhead. The contents in the FIFO are not necessarily linearly sampled in time when the device is in aperture mode.

Aperture Range Requirements

Program the aperture range requirements for both X and Y through register 0x0B. Range requirements are expressed as distance, in position LSBs. The blanking aperture extends from the initial touch position, both $\pm\Delta X$ and $\pm\Delta Y$ with 12-bit resolution (1 LSB = 1/4096 of the corresponding screen dimension). An aperture setting of 0x00 effectively disables aperture checking with all measurement data logged to the FIFO. Apertures are specified in a power-of-two format: $\Delta X = 2^{APRX[3:0]-1}$ and $\Delta Y = 2^{APRY[3:0]-1}$.

Table 13. FIFO Event Tags

EVENT	TAG[1:0]
Initial touch	00
Midpress	01
Release (data invalid)	10
End of file indicator (FIFO data invalid)	11

Low-Power, Ultra-Small Resistive Touch-Screen Controllers with I²C/SPI Interface

For example:

0000 = 2⁻¹ LSB = aperture checking disabled

0001 = 2⁽¹⁻¹⁾ LSB = ±1 LSB

0010 = 2⁽²⁻¹⁾ LSB = ±2 LSB

0011 = 2⁽³⁻¹⁾ LSB = ±4 LSB

...

1001 = 2⁽⁹⁻¹⁾ LSB = ±256 LSB (1/16 of the touch screen in each direction)

1010 = 2⁽¹⁰⁻¹⁾ LSB = ±512 LSB (1/8 of the touch screen in each direction)

1011 = 2⁽¹¹⁻¹⁾ LSB = ±1024 LSB (1/4 of the touch screen in each direction)

1100 = 2⁽¹²⁻¹⁾ LSB = ±2048 LSB (1/2 of the touch screen in each direction)

1101 to 1111 = aperture checking disabled

FIFO Aperture Criteria

In autonomous mode with aperture engaged, new data is written to the FIFO, and an interrupt is issued when the following conditions occur (aperture mode is not available in direct conversion mode).

New Panel Touch Initiated

The FIFO updates and issues an interrupt when a new touch is observed on the panel (data tag = 00). This event occurs regardless of the current aperture setting and the previous touch location so that multiple presses in the same location can be observed and registered.

Continuous Panel Touch Terminated

The FIFO updates and issues an interrupt when a continuous panel touch is terminated (data tag = 10). This event occurs regardless of the current aperture setting and the previous continuous touch location(s) so that multiple presses in the same location can be observed and registered.

Continuous Panel Touch

Measurement Meets Aperture Criteria

The MAX11800/MAX11801 log the measurement data to the FIFO and issue an interrupt when a measurement during a continuous panel touch (event tag = 01) meets the aperture criteria (i.e., lies on or outside the aperture boundary). This event occurs when the point of contact is dragged across the touch screen. Only the ΔX or ΔY aperture criteria need to be met and a greater than or equal to qualification criterion is applied. If the change in X position or change in Y position exceeds the aperture criteria, then an interrupt is generated.

Applications Information

Using Aperture Mode

Aperture mode is only supported in the MAX11800/MAX11801. The MAX11800/MAX11801 accommodate touch-panel applications where limited resolution in both time and space can be traded off for reduced microprocessor activity. A simulated keypad is an example of an application where autonomous conversion mode with aperture checking could yield an efficient solution.

The AP determines the durations of touch-screen presses. An issuance of \overline{TIRQ} interrupts accompanies all FIFO events. The interrupts clear when all existing data is read back by the AP, allowing the AP to correctly interpret held panel data.

The FIFO updates immediately when a new touch event is detected. The system assumes that the panel touch is continuous after the AP receives the interrupt. The MAX11800/MAX11801 continue to scan the panel at the user-programmed sample rate. The FIFO updates when the measurement data shows that the panel touch location moves (i.e., a measurement exceeds either of the selected aperture ranges). The FIFO also updates upon detection of a panel release. The AP determines the duration of the press by observing the time between the leading edge of the touch (tag 00) and the release edge of the touch (tag 10). All midpress data (tag 01) are interpreted as part of a dragged touch event.

All valid touch events log two data points into the FIFO: an initial data point at the beginning of the touch (tag 00) and a release data point at the termination of the touch (tag 10). Discard release edge position data as invalid as the MAX11800/MAX11801 cannot determine at which point in the ADC conversion cycle the panel is released during the measurement operation. If the release occurs while the ADC is actively sampling the panel, the results are invalid. Only initial and midpress position data are reliable.

Any touch event too short in duration to log both initial and release data points is recorded in the FIFO as a release (tag 10) and discarded as a glitch event.

Measuring durations of panel touches becomes impractical when the AP services the MAX11800/MAX11801 at lower than the operating speed of the devices and the panel combined. The AP cannot time the duration between panel touches when both the initial and release data points can be logged before the initial interrupt is serviced. Do not allow the FIFO to overflow as touch information can be lost and the FIFO content becomes invalid.

Low-Power, Ultra-Small Resistive Touch-Screen Controllers with I²C/SPI Interface

When the MAX11800/MAX11801 operate in autonomous conversion mode with low or no aperture ranges, the FIFO and interrupt activity occur frequently with the AP servicing the devices frequently to avoid loss of data due to limited FIFO depth. For this reason, do not perform autonomous conversion for applications where a high resolution in either space or time is required. Use direct conversion mode when requiring a high resolution in either space or time.

Examples of Using Aperture Mode

Figure 16 shows an example of a touch sequence. A dragged touch sequence is initiated at position 1 and continues through to position 5. While multiple samples are taken during this sequence, only those samples

that meet aperture requirements are enumerated and are shown with the corresponding aperture ranges. Positions 6 and 7 show a subsequent momentary press event.

Figure 16 shows the anticipated interrupt waveforms in several operating modes. The first waveform shows interrupt operation assuming that aperture mode is enabled (with $\Delta X = \Delta Y = 4$ LSBs), assuming that the AP service interrupts at a frequency faster than the selected TSC sample rate. Each qualifying sample induces a FIFO event and an interrupt pulse as shown. Timing between FIFO events can be timed by the AP to determine duration information. Table 14 shows the read-back data assuming that the FIFO does not fill up.

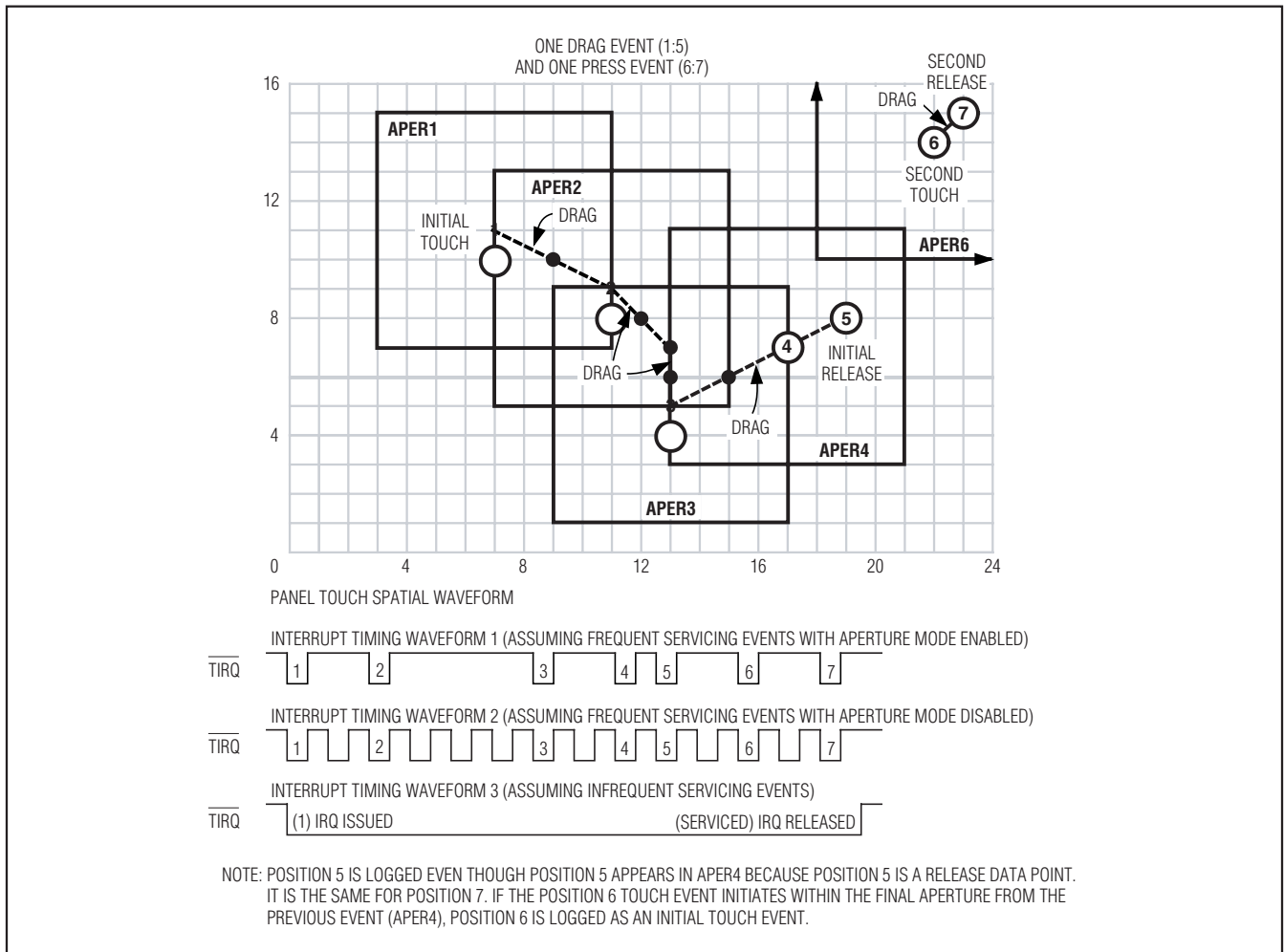

Figure 16. Aperture Usage Example Waveforms—MAX11800/MAX11801

Low-Power, Ultra-Small Resistive Touch-Screen Controllers with I²C/SPI Interface

The second waveform shows an interrupt operation assuming that aperture mode is disabled (or that $\Delta X = \Delta Y = 0$ LSB), assuming that the AP service interrupts at a frequency faster than the selected TSC sample rate. Every sample induces a FIFO event and an interrupt pulse as shown. The interrupt waveform is significantly busier than that shown in the first waveform. Duration information can now be directly determined from the FIFO samples since each sample is logged and occurs

at the programmed sample rate. Table 15 lists the read-back data assuming the FIFO does not fill up.

The third waveform in Figure 16 shows an interrupt operation assuming that the MAX11800/MAX11801 are infrequently serviced. Ensure that the FIFO does not overflow. No duration information is available at resolutions below the servicing rate. Either the set of data shown in Table 14 or the set shown in Table 15 appears in the FIFO when read, depending on the aperture setting.

Table 14. Readback and FIFO Contents with Aperture Mode Enabled

SAMPLE	X	Y	TAG	COMMENT
1	7	11	00	Initial event (beginning of first touch)
2	11	9	01	Midpress event
3	13	5	01	Midpress event
4	17	7	01	Midpress event (last valid position data)
5	19	6	10	Release event (end of first touch, ignore position data)
6	22	14	00	Initial event (beginning of second touch)
7	23	15	10	Release event (end of second touch, ignore position data)

Table 15. Readback and FIFO Contents with Aperture Mode Disabled

SAMPLE	X	Y	TAG	COMMENT
1	7	11	00	Initial event (beginning of first touch)
1a	9	10	01	Midpress event
2	11	9	01	Midpress event
2a	12	8	01	Midpress event
2b	13	7	01	Midpress event
2c	13	6	01	Midpress event
3	13	5	01	Midpress event
3a	15	6	01	Midpress event
4	17	7	01	Midpress event (last valid position data)
5	19	6	10	Release event (end of first touch, ignore position data)
6	22	14	00	Initial event (beginning of second touch)
7	23	15	10	Release event (end of second touch, ignore position data)

Low-Power, Ultra-Small Resistive Touch-Screen Controllers with I²C/SPI Interface

SPI Communication Sequence (MAX11800/MAX11802)

The SPI interface consists of three inputs, DIN, DCLK, \overline{CS} , and one output, DOUT. A logic-high on \overline{CS} disables the MAX11800/MAX11802 digital interface and places DOUT in a high-impedance state. Pulling \overline{CS} low enables the MAX11800/MAX11802 digital interface. The MAX11800/MAX11802 provide two possible implementations of SPI instructions. In rising-edge-driven operations, the devices are able to run at maximum clock speeds. Carefully consider the hold time requirements of the MAX11800/MAX11802 and minimize board skew contributions when running the MAX11800/MAX11802 at maximum clock speed. In falling-edge-driven operations, the device is less sensitive to board skew contributions, but slower clock speeds are required to meet the MAX11800/MAX11802 setup time requirements. For the MAX11800/MAX11802, read patterns output data is either latched on the rising edge running at maximum clock rates or on the falling edges running at reduced clock rates.

SPI Configuration Register Write (MAX11800/MAX11802)

Figure 17 shows the supported write operation sequence for the MAX11800/MAX11802. A single configuration register can be written in a 2-byte operation, composed of a target register address (A[6:0], plus a write mode indicator bit) followed by data to be written to the target register (D[7:0]).

During write sequences, the DOUT line is not accessed by the SPI. DOUT remains high impedance throughout the command. Using the optional bus holder, the DOUT line retains the previous value unless altered by a device sharing the bus.

The MAX11800/MAX11802 SPI interface supports multiple register write operations within a single sequence as shown in Figure 18. By repeating the address plus data byte pairs (in write mode), an unlimited number of registers can be written in a single transfer. Do not permit to combine write and read operations within the same SPI sequence.

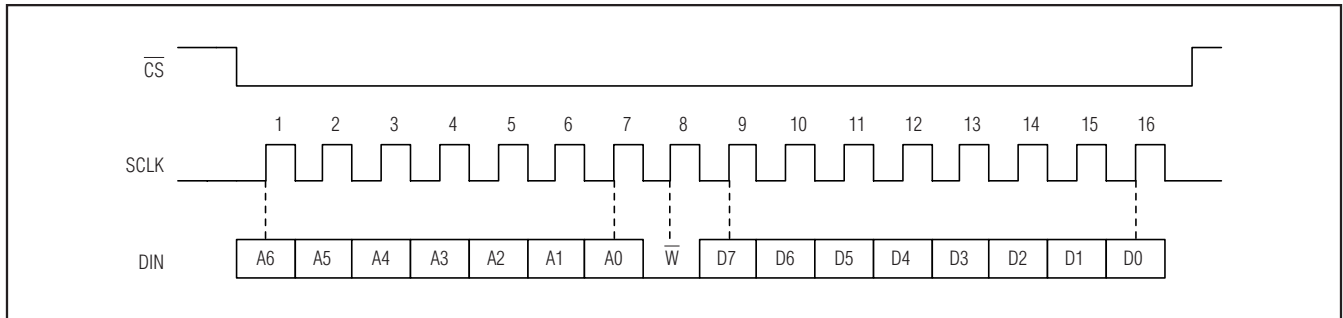

Figure 17. SPI Single Configuration Register Write Sequence—MAX11800/MAX11802

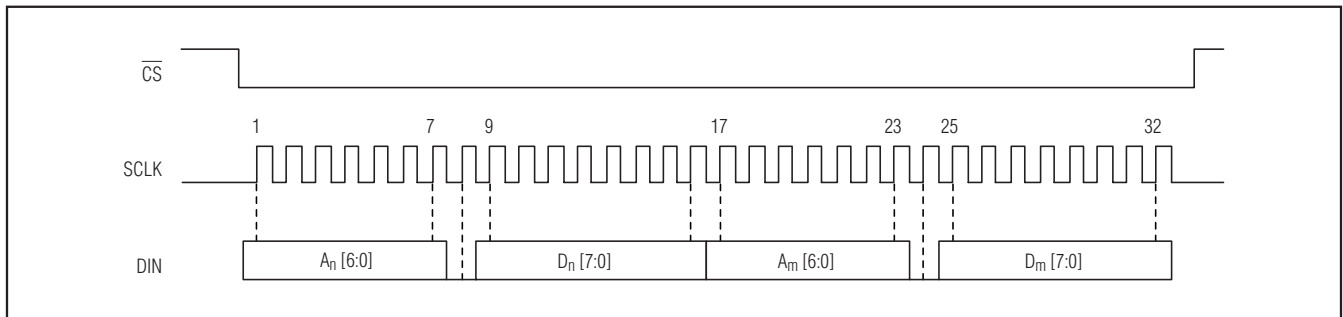

Figure 18. SPI Multiple Configuration Register Write Sequence—MAX11800/MAX11802

Low-Power, Ultra-Small Resistive Touch-Screen Controllers with I²C/SPI Interface

SPI Configuration or Result Register Read (MAX11800/MAX11802)

Figure 19 shows the read operation sequence for the MAX11800/MAX11802. A single configuration register can be read back in a 2-byte operation, composed of a requested register address (A[6:0], plus a read mode indicator bit) followed by the data contents from that register (D[7:0]).

During read operations, the SPI takes control of the DOUT line following the eight SCLK rising edge. The SPI retains control of the DOUT line until \overline{CS} rises, terminating the operation. To support multiple register readback operations, data continues to be ported following the 16th rising clock edge. For single-byte transfers, this sub-bit information can be ignored, shown as S, in Figure 19.

The DOUT output on the MAX11800/MAX11802 includes an optional bus holder to prevent the DOUT line from maintaining an indeterminate state when vacated by the device in the absence of an external bus pullup or bus sharing devices. The bus holder is designed not to interfere with other drivers sharing the DOUT line and holds the last valid state of the line, regardless of source. Disable the bus holder when not needed.

The MAX11800/MAX11802 support the combination of the DIN and DOUT lines. To avoid data contention and possible high current states, the master device must relinquish control of the combined line at the 8th clock rising edge, allowing the MAX11800/MAX11802 to access the line through the end of the sequence. This is terminated on the rising edge of \overline{CS} . See the *SPI Timing Characteristics* for relevant details.

The MAX11800/MAX11802 also support multiple register readback operations using a single command. The protocol requires the user to supply an initial starting register location, followed by an unlimited number of clock pulses for data readback.

The first data read back is from the start register. The MAX11800/MAX11802 internal autoincrement counter manages the data readback in later cycles. If autoincrement

is supported, the next register location is read back. If not, the last valid register location is read back (see the *Command and Register Map* section for the autoincrement attributes of each register). The following example shows a valid sequence for the readback of three register locations (D_i through D_{i+2}).

The autoincrement reads only the X, Y, Z1, Z2, and AUX result registers preventing inadvertent readback of unrelated or reserved data locations. For example, if beginning at the XMSB register, a user can cycle through the XLSB register to the YMSB register and so forth up to the AUXLSB register. The MAX11800/MAX11802 do not autoincrement beyond the AUXLSB register. If clock cycles continue to be given, the AUXLSB register readback is repeated.

The FIFO register does not autoincrement, which allows multiple readbacks of the same location. This allows the access of multiple FIFO memory blocks with a single read operation. When reading back FIFO registers, data management is handled in blocks not bytes. As a result, when an SPI read operation supplies at least one cycle of readback of the first byte of a FIFO block, the entire block is marked as read, regardless of whether the block or even byte readback is run to completion.

To illustrate, assume the MAX11800 is in autonomous mode performing XY conversions and a FIFO readback is requested starting at register 0x50. Clock cycles 9 to 40 are required to complete the readback of the first available FIFO block $i = \{XMSB_i, XLSB_i, YMSB_i, YLSB_i\}$ with the device updating in response to the 8th to 39th clock rising edges. The host processor can complete the readback data latching of YLSB_i[0] either on the 39th falling edge or the 40th rising edge. To support a continued readback of further FIFO blocks, the device updates the DOUT line to XMSB_{i+1}[7] in response to the 40th clock rising edge (though block_{i+1} is not marked as read). If the AP supplies a 42nd clock rising edge, the FIFO block_{i+1}, if present, is marked as read, regardless of whether any further clock cycles are provided.

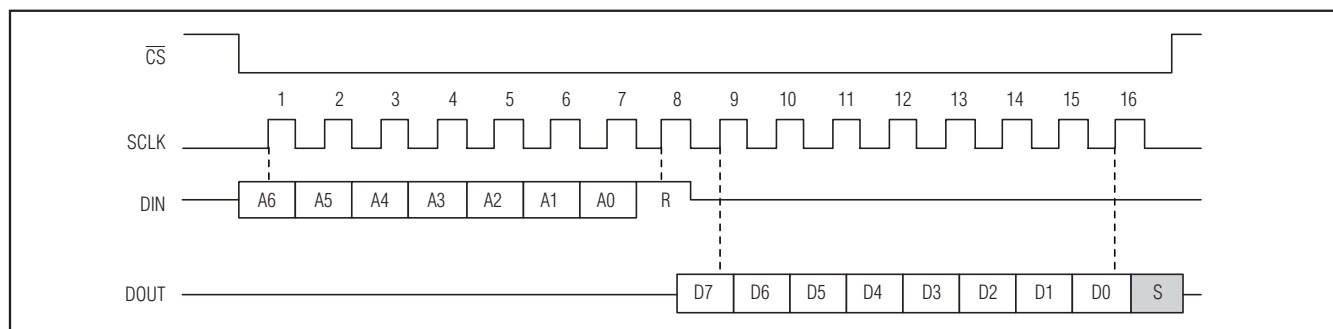

Figure 19. SPI Single-Byte Register Read Sequence—MAX11800/MAX11802

Low-Power, Ultra-Small Resistive Touch-Screen Controllers with I²C/SPI Interface

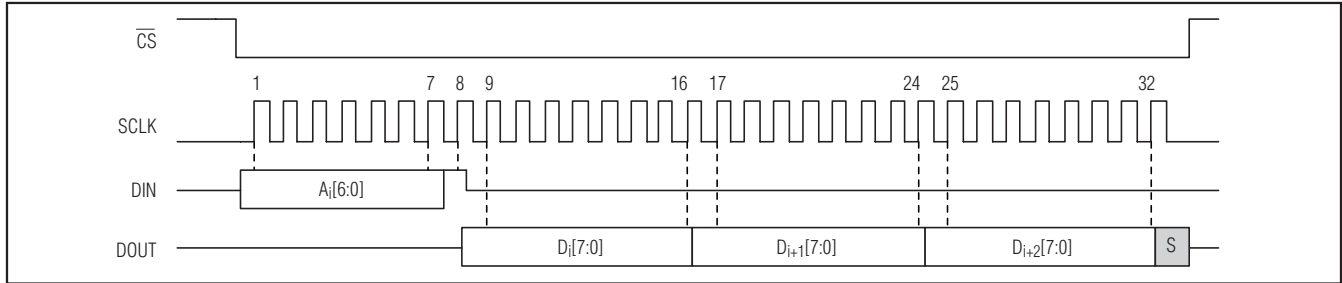

Figure 20. SPI Multiple-Byte Register Read Sequence—MAX11800/MAX11802

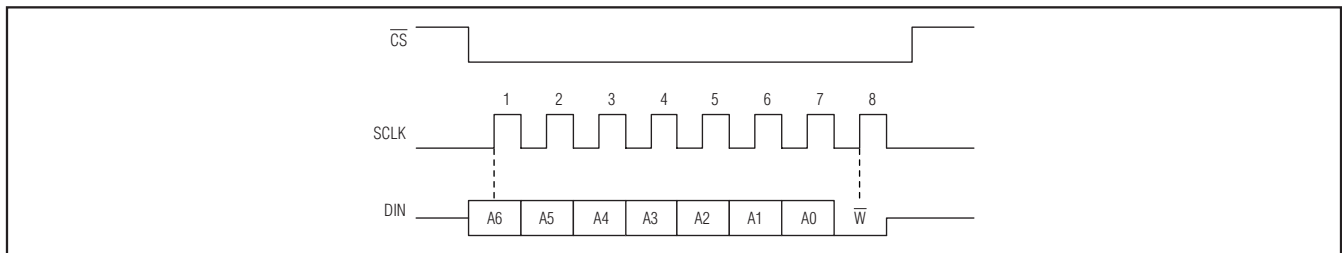

Figure 21. SPI Conversion Command—MAX11800/MAX11802

SPI Conversion Command (MAX11800/MAX11802)

The sequence in Figures 20 and 21 shows the required command format for issuing conversion requests. A conversion request cannot be paired with multiple commands or instructions. Any conversion command issued while previous commands are being executed is ignored.

I²C-Supported Sequence (MAX11801/MAX11803)

The MAX11801/MAX11803 feature an I²C/SMBus™-compatible, 2-wire serial interface consisting of a serial-data line (SDA) and a serial-clock line (SCL). SDA and SCL facilitate communication between the MAX11801/MAX11803 and the master at clock rates up to 400kHz. Figure 22 shows the 2-wire interface timing diagram. The master generates SCL and initiates data transfer on the bus.

The master device writes data to the MAX11801/MAX11803 by transmitting the proper slave address followed by the register address and then the data word. Each transmit sequence is framed by a START (S) or repeated START (Sr) condition and a STOP (P) condition. Each word transmitted to the MAX11801/MAX11803 is 8 bits long and is followed by an acknowledge clock pulse.

A master reading data from the MAX11801/MAX11803 transmits the proper slave address followed by a series

of nine SCL pulses. The MAX11801/MAX11803 transmits data on SDA in sync with the master-generated SCL pulses. The master acknowledges receipt of each byte of data. Each read sequence is framed by a START (S) or repeated START (Sr) condition, a not-acknowledge, and a STOP (P) condition. SDA operates as both an input and an open-drain output.

A pullup resistor, typically greater than 500Ω, is required on SDA. SCL operates only as an input. A pullup resistor, typically greater than 500Ω, is required on SCL if there are multiple masters on the bus, or if the single master has an open-drain SCL output. Series resistors in line with SDA and SCL are optional. Series resistors protect the digital inputs of the MAX11801/MAX11803 from high-voltage spikes on the bus lines and minimize crosstalk and undershoot of the bus signals.

Bit Transfer

One data bit is transferred during each SCL cycle. The data on SDA must remain stable during the high period of the SCL pulse. Changes in SDA while SCL is high are control signals (see the *START and STOP Conditions* section).

START and STOP Conditions

SDA and SCL idle high when the bus is not in use. A master initiates communication by issuing a START condition. A START condition is a high-to-low transition

SMBus is a trademark of Intel Corp.

Low-Power, Ultra-Small Resistive Touch-Screen Controllers with I²C/SPI Interface

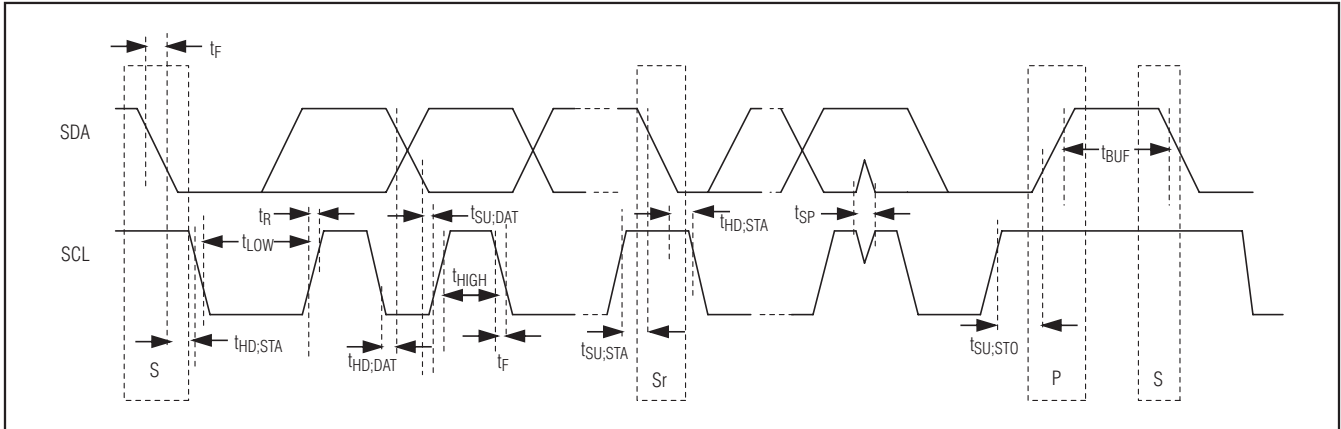

Figure 22. 2-Wire Interface Timing Diagram

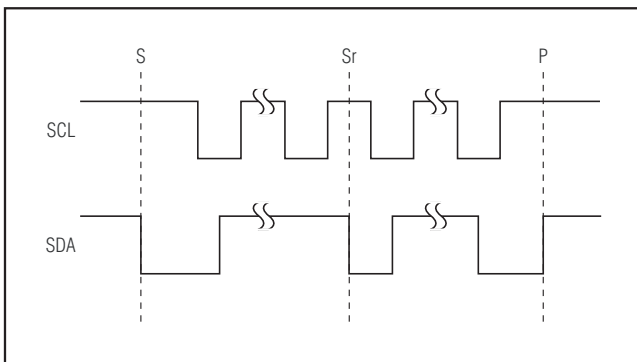

Figure 23. START, STOP, and Repeated START Conditions

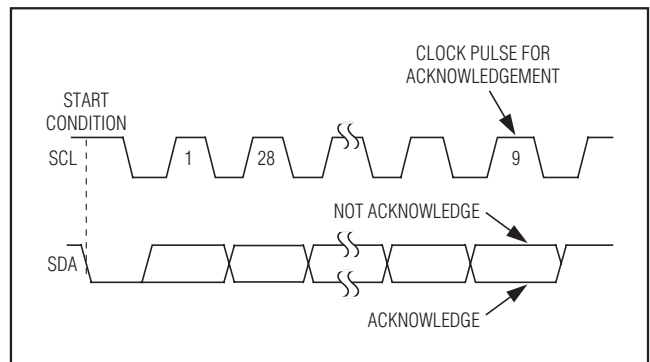

Figure 24. Acknowledge

on SDA with SCL high. A STOP condition is a low-to-high transition on SDA while SCL is high (Figure 23). A START condition from the master signals the beginning of a transmission to the MAX11801/MAX11803. The master terminates transmission and frees the bus by issuing a STOP condition. The bus remains active if a repeated START condition is generated instead of a STOP condition.

Early STOP Conditions

The MAX11801/MAX11803 recognize a STOP condition at any point during data transmission, except if the STOP condition occurs in the same high pulse as a START condition. For proper operation, do not send a STOP condition during the same SCL high pulse as the START condition.

Slave Address

The slave address is defined as the seven most significant bits (MSBs) followed by the read/write (R/W). For the MAX11801/MAX11803 the seven most significant bits

are 10010 A1 A0, where A1 and A0 are user configurable through the address input pins A1 and A0. The LSB is the read/write bit. Setting the R/W bit to 1 configures the MAX11801/MAX11803 for read mode. Setting the R/W bit to 0 configures the MAX11801/MAX11803 for write mode. The address is the first byte of information sent to the MAX11801/MAX11803 after the START condition. See Figures 25 and 26 for details.

$$I^2C \text{ Slave Address} = 10010A1A0R/\overline{W}$$

I²C Register Address

The register addresses are defined as the seven most significant bits (MSBs) followed by a don't care bit. The format is N N N N N N N X, where N is the register address and X is a don't care.

Acknowledge

The acknowledge bit (ACK) is a clocked 9th bit that the MAX11801/MAX11803 use to handshake receipt each byte of data when in write mode (see Figure 24). The MAX11801/MAX11803 pull down SDA during the entire

Low-Power, Ultra-Small Resistive Touch-Screen Controllers with I²C/SPI Interface

master-generated 9th clock pulse if the previous byte is successfully received. Monitoring ACK allows for detection of unsuccessful data transfers. An unsuccessful data transfer occurs if a receiving device is busy or if a system fault has occurred. In the event of an unsuccessful data transfer, the bus master retries communication. The master pulls down SDA during the 9th clock cycle to acknowledge receipt of data when the MAX11801/MAX11803 are in read mode. An acknowledge is sent by the master after each read byte to allow data transfer to continue. A not-acknowledge is sent when the master reads the final byte of data from the MAX11801/MAX11803, followed by a STOP condition.

Write Data Format

A minimum write sequence to the MAX11801/MAX11803 includes transmission of a START condition, the slave address with the R/W bit set to 0, 1 byte of data to select the internal register address pointer, 1 byte of data written to the selected register, and a STOP condition. Figure 25 illustrates the proper frame format for writing 1 byte of data to the MAX11801/MAX11803. Figure 26 illustrates the frame format for writing N-bytes of data to the MAX11801/MAX11803.

The slave address with the R/W bit set to 0 indicates that the master intends to write data to the MAX11801/MAX11803. The MAX11801/MAX11803 acknowledge receipt of the address byte during the master-generated 9th SCL pulse.

The second byte transmitted from the master configures the MAX11801/MAX11803's internal register address pointer. The pointer tells the MAX11801/MAX11803 where to write the next byte of data. Note that the MAX11801/MAX11803 use a 7-bit register pointer format, and the selection should be left-justified within the register byte (the last bit in the register byte is a don't care). An acknowledge pulse is sent by the MAX11801/MAX11803 upon receipt of the address pointer data.

The third byte sent to the MAX11801/MAX11803 contains the data that is written to the chosen register. An acknowledge pulse from the MAX11801/MAX11803 signals receipt of the data byte. **The MAX11801/MAX11803 do not support autoincrement in write mode.** However, by repeating multiple register address byte + data byte pairs (bytes 2 and 3 in Figure 25) the user can perform multiple register writes within a single transfer. **There is no limit as to how many registers the user can write with a single command sequence, but only commands listed as "pairable" can be sequenced in this manner.** For example, the I²C master can perform multiple register writes to set up all required conversion options and then issue a separate I²C command to start a conversion process. Figure 26 illustrates how to write to multiple registers with one frame. The master signals the end of transmission by issuing a STOP condition. Register addresses greater than 0x0B are reserved. Do not write to these addresses.

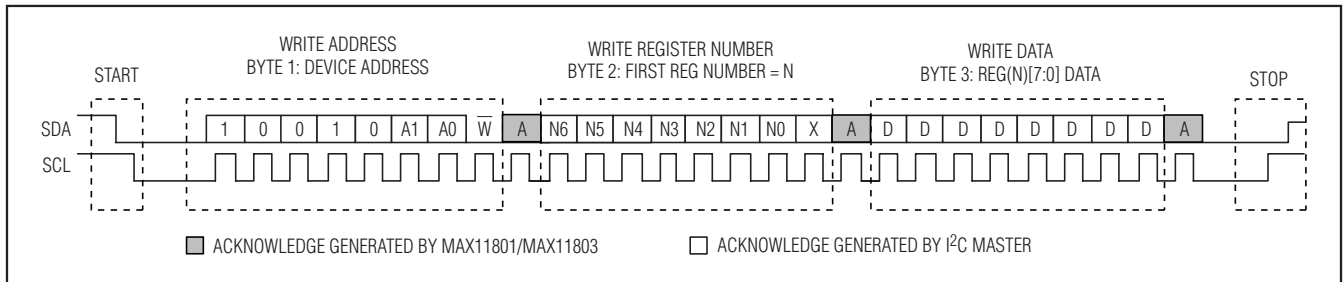

Figure 25. I²C Single Write Sequence

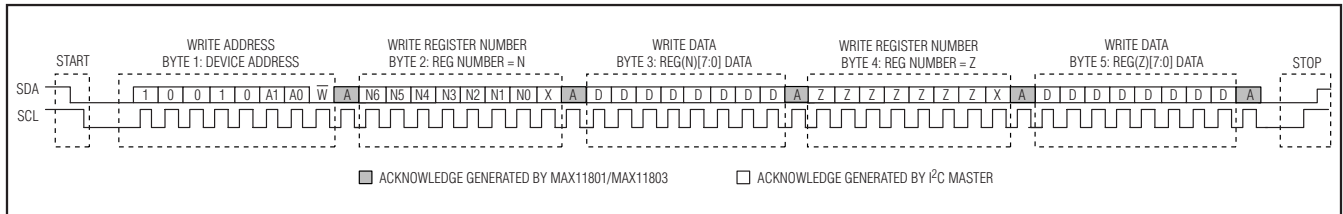

Figure 26. I²C Multiple Write Sequence

Low-Power, Ultra-Small Resistive Touch-Screen Controllers with I²C/SPI Interface

Read Data Format

Send the slave address with the R/W bit set to 1 to initiate a read operation. The MAX11801/MAX11803 acknowledge receipt of its slave address by pulling SDA low during the 9th SCL clock pulse. Transmitted data is valid on the rising edge of SCL. A STOP condition can be issued after any number of read data bytes.

The address pointer should be preset to a specific register before a read command is issued. The master presets the address pointer by first sending the MAX11801/MAX11803's slave address with the R/W bit set to 0 followed by the selected register address. A repeated START condition is then sent followed by the slave address with the R/W bit set to 1. The MAX11801/MAX11803 then transmit the contents of the selected

register. If the selected register supports autoincrement, the register pointer automatically increments after transmitting each data byte, making data in the next register location available for access in the same transfer. Some registers do not support autoincrement, usually because they are at the end of a functional section or, in the case of the FIFO, store multiple records.

The master acknowledges receipt of each data byte received from the MAX11801/MAX11803 during the "acknowledge clock period." If the master requires more data from the MAX11801/MAX11803, it brings the acknowledge line low, indicating more data is expected. This sequence is repeated until the master terminates with a not-acknowledge (~A) followed by a STOP condition. Figure 27 illustrates the frame format for

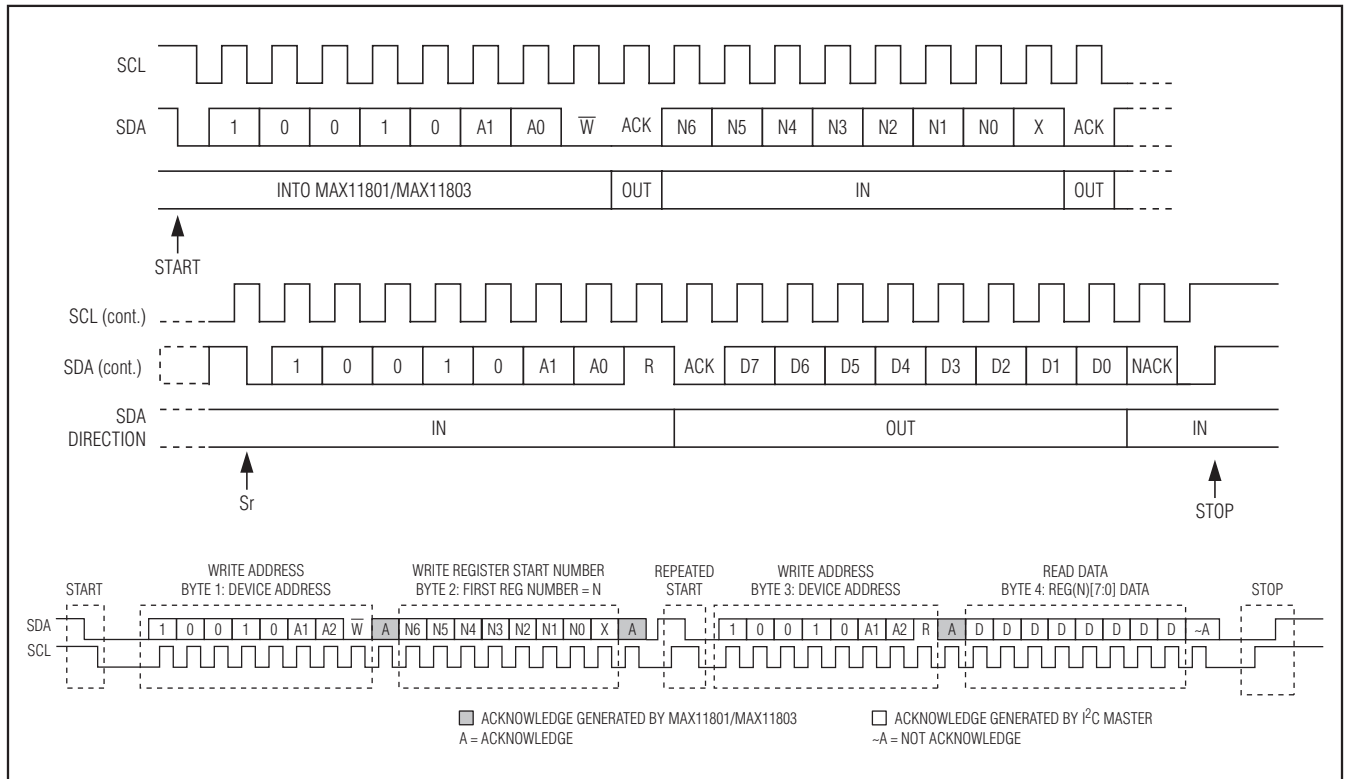

Figure 27. Basic Single Read Sequence

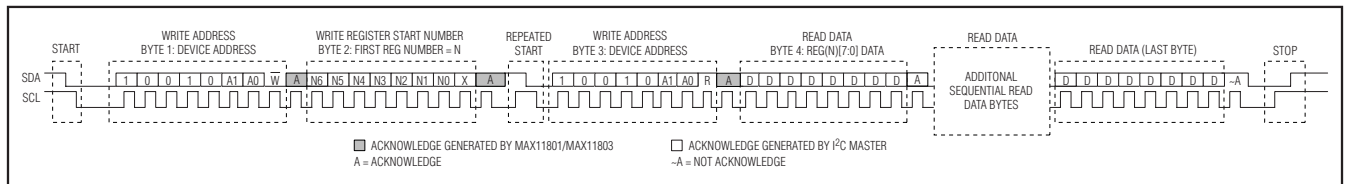

Figure 28. I²C Multiple Read Sequence

Low-Power, Ultra-Small Resistive Touch-Screen Controllers with I²C/SPI Interface

reading one byte from the MAX11801/MAX11803. Figure 28 illustrates the frame format for reading multiple bytes from the MAX11801/MAX11803.

As previously indicated, the MAX11801/MAX11803 read sequence does not limit how many bytes one can read. Where allowed, the internal register counter keeps incrementing as additional bytes are requested, the first byte out is Reg(N), next byte out is Reg(N+1), next byte out is Reg(N+2), and so on. The user needs to track the incremented register address. **Acknowledge pulses from the master are not required to autoincrement the internal register location; the internal register location updates on each byte.** See the register map for details governing the incrementing of register addresses.

Some registers autoincrement only up to a point (for example, the X, Y, Z1, Z2, and AUX result registers). This is to prevent inadvertent readback of unrelated or reserved data locations. For example, if beginning at the XMSB register, a user can cycle through the XLSB register to the YMSB register and so forth up to the AUXLSB register. The MAX11801/MAX11803 do not autoincrement beyond the AUXLSB register; if bytes continue to be given, the AUXLSB register readback is repeated.

Some registers do not autoincrement (for example, the FIFO register). This is intentional as it allows multiple readbacks of the same location (in this case, allowing the user to access multiple FIFO memory blocks with a single read operation). **Note that when reading back FIFO registers, data management is handled in blocks (not bytes);** thus, if an I²C read operation supplies at least one cycle for readback of the first byte of a FIFO block, the entire block is marked as read (regardless of whether the block or even byte read back is run to completion).

Streamlined I²C Read Operations

The MAX11801/MAX11803 support several streamlined readback behaviors for several commands to significantly improve data transfer efficiency.

Resumed Read Operations

The MAX11801/MAX11803 internal address pointer autoincrements after each read data byte. This autoincrement feature allows all registers to be read sequentially within one continuous frame. A STOP condition can be issued after any number of read data bytes. If a readback sequence is stopped, readback can later be resumed from the current (autoincremented) register location; it is not necessary to supply the initial register address and register selection sequence. Users can simply begin with a START followed by the device slave address with R/W set high. Following the acknowledge, data readback commences from the previous register address (next register address after the first one is successfully read). This sequence is designated as a “streamlined sequence” and is shown in Figure 29.

Resumed Read Operation of the FIFO Register (MAX11801)

If the user accesses the FIFO register (the FIFO does not autoincrement) and reads several conversion results and then stops, when returning for more FIFO data it is only necessary to simply issue the streamlined readback sequence to continue to gather results from the FIFO. Thus, once the MAX11801 is placed in autonomous conversion mode, the user needs only issue the full readback sequence once for the initial FIFO access. From this point on, streamlined read access to the part resumes at the next available FIFO location (unless an intervening command is issued to modify the device’s register address pointer).

Resumed Read Operation of the Results Registers (MAX11801/MAX11803)

Likewise, if a user is reading back result registers, the user can begin with XMSB and autoincrement to XLSB, and then stop. If the user resumes by simply issuing the streamlined readback sequence, data readback commences from the YMSB location. This behavior remains valid unless another direct conversion or configuration command has been issued (see next).

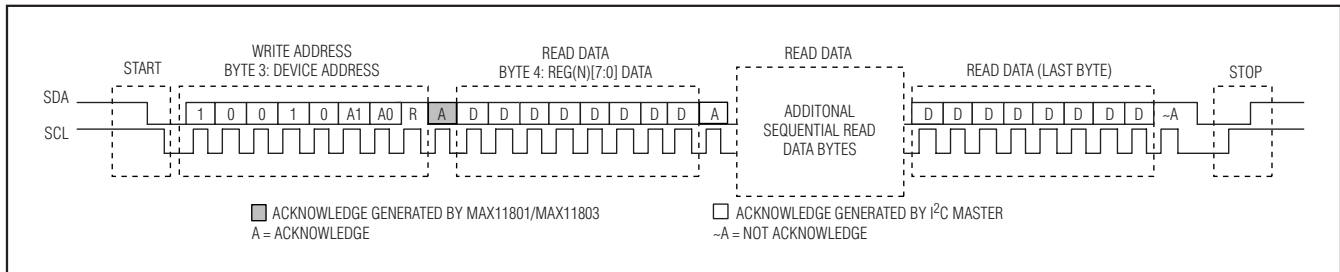

Figure 29. I²C Streamlined Read Sequence

Low-Power, Ultra-Small Resistive Touch-Screen Controllers with I²C/SPI Interface

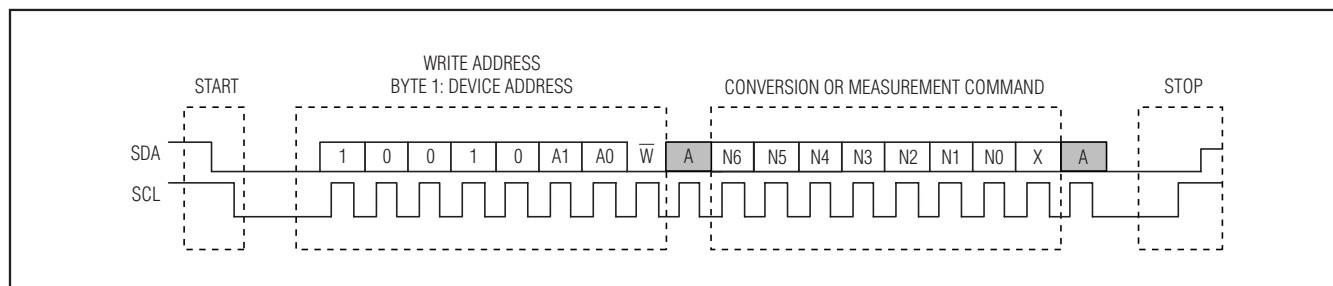

Figure 30. I²C Conversion and Measurement Commands

Direct Conversion Read Operations

All direct conversion commands automatically set the readback target register, streamlining data gathering operations. See the register map for specific details for all such commands. For example, if the user writes a command requesting an XY combined measurement, the MAX11801/MAX11803 automatically set the default readback register pointer to the XMSB location. Thus, if the XY command is issued and allowed to complete, it can then be followed directly by a streamlined read sequence of the format, as shown in Figure 29, and newly acquired register data is read back, commencing with the XMSB register.

Note that accepted direct conversion commands always modify the current internal register location and effectively override the resumed readback behaviors and any register settings made in response to previously completed direct conversion commands. Users wishing to override this behavior can use still use the standard readback sequences of the format, as shown in Figures 28 and 29.

Read Operations Following Write Operations

If the streamlined readback sequence is issued following a configuration write operation, data readback commences from the last written register location. Thus, if the user modifies the contents of the Operating Mode Configuration register (0x0B) using a write sequence and then issues a streamlined readback sequence, the contents of register 0x0B are provided.

Note that register write operations always modify the current internal register location and effectively override the resumed readback behaviors.

I²C Conversion and Measurement Commands (MAX11801/MAX11803)

Figure 30 shows the required command format for issuing conversion and measurement requests. A request cannot be paired with multiple commands or

instructions. Any command issued while previous commands are being executed is ignored and the readback target register is not modified.

Command and Register Map

The command map consists of the user-configuration registers (read/write), TSC data readback commands (read only), and TSC panel setup and conversion commands (write only).

User-Accessible Registers

There are six blocks of user-accessible registers and commands that control all operations of the MAX11800–MAX11803. The register blocks and commands consist of the following:

- 1) Status and Configuration Registers: 00h to 0Bh
 - Sets modes of operation—ACM or DCM
 - Settings to accommodate various panel sizes (panel time constant)
 - Averaging and noise settings
 - Measurement resolution
 - Auxiliary settings
 - General part status reporting
- 2) FIFO Data Readback Command: 50h
 - Autonomous conversion mode (MAX11800/MAX11801)
 - Allows reading FIFO contents when operating in ACM (MAX11800/MAX11801)
- 3) Data Readback Commands: 52h to 5Bh
 - Direct conversion mode (MAX11800/MAX11802)
 - Allows reading measurement results when in DCM
- 4) I²C Readback Registers: 52h to 58h
 - Direct conversion mode (MAX11801/MAX11803)
 - Allows reading measurement results when in DCM

Low-Power, Ultra-Small Resistive Touch-Screen Controllers with I²C/SPI Interface

Table 16. SPI Command and Data Format: 8 Bits

BYTE							
BIT 7	BIT 6	BIT 5	BIT 4	BIT 3	BIT 2	BIT 1	BIT 0
R6	R5	R4	R3	R2	R1	R0 (CONT)	R \bar{W}
Command or Data							1/0

Table 17. I²C Command and Data Format: 8 Bits Plus ACK

BYTE								ACK BIT
BIT 7	BIT 6	BIT 5	BIT 4	BIT 3	BIT 2	BIT 1	BIT 0	
R6	R5	R4	R3	R2	R1	R0	X (Don't Care)	1/0
Command or Data								1/0

5) Panel Setup Commands: 6Ah to 6Fh

- Sets up panel prior to making X, Y, Z1, or Z2 measurements

6) Measurement Commands: 70h to 7Fh

- Performs specified measurement (X, Y, Z1, and/or Z2)

The commands to read or write the user-accessible registers are always the same. However, the data format varies based on whether using an SPI or I²C interface. Tables 16 and 17 show the differences between SPI and I²C protocols. For SPI, the R \bar{W} bit is embedded in the 8-bit byte and always occupies the LSB position. For I²C, the protocol is always 8-bit byte followed by an acknowledge bit, for a total of 9 bits. The LSB in I²C format is a don't care. In write mode, for I²C, the LSB is ignored internal to the MAX11800-MAX11803, so setting it to 0 or 1 has no effect.

Status and Configuration Registers

The status and configuration registers are located in block 0x00 to 0x0B. See Table 18. All user-configuration register write mode operations are pairable within the SPI/I²C interface. Multiple locations can be written under a single instruction with a register byte followed by a data. All user-configuration read-mode operations support autoincrement. For example, if location 0x00 is read back and more clock pulses are issued, readback will proceed through location 0x01 and so forth. The user should set all configuration registers to the desired values before issuing direct conversion operations or placing MAX11800/MAX11801 in autonomous mode.

Data Readback Commands

Autonomous Conversion Mode

Use the readback command 0x50 to read back available FIFO data in autonomous conversion modes (AUTO = 1) (MAX11800/MAX11801). The oldest available data is read out first. Data blocks vary from 32 to 64 bits in length, depending on the scan mode selected. Reading back longer than one block results in reading back the next available block. The end-of-file indicator (event tag = 11) is read back when no unread data is available in the FIFO. This command does not autoincrement and the register address does not advance beyond 0x50. See the *FIFO Data Block Readback Structure* section for more details.

Direct Conversion Mode

Use the readback commands 0x52 to 0x5B to read back available measurement data gathered in direct conversion mode (AUTO = 0). Random data access is supported within this register space and the commands autoincrement up to register 0x5B. The register address does not advance beyond register 0x5B. Attempting to read back a pending conversion results in data being tagged invalid. See the *Direct Conversion Mode Operations* section for more details.

The panel setup and conversion commands are not pairable in write mode as each command modifies the panel setting both during and after the command, based on conversion executions and CONT bit settings. All direct conversion commands modify the expected I²C read register location to support the data streamlining protocol. Table 21 shows the resulting read register settings by command type applicable to I²C variants.

Low-Power, Ultra-Small Resistive Touch-Screen Controllers with I²C/SPI Interface

MAX11800-MAX11803

Table 18. Status and Configuration Registers

HEX (NOTE 1)	ACCESS	PAIRABLE	AUTO-INCREMENT	DATA LENGTH	MAX11800/ MAX11801	MAX11802/ MAX11803	FUNCTION
00h	R	No	Yes	8	Yes	Yes (Note 2)	General Status
01h	R/W	Yes	Yes	8	Yes	Yes	General Configuration
02h	R/W	Yes	Yes	8	Yes	Yes	Measurement Resolution Configuration
03h	R/W	Yes	Yes	8	Yes	Yes	Measurement Averaging Configuration
04h	R/W	Yes	Yes	8	Yes	Yes	ADC Sample Time Configuration
05h	R/W	Yes	Yes	8	Yes	Yes	Panel Setup Times Configuration
06h	R/W	Yes	Yes	8	Yes	Yes	ADC Delay Initial Conversion Configuration
07h	R/W	Yes	Yes	8	Yes	Yes	Touch-Detect Pullup Times Configuration
08h	R/W	Yes	Yes	8	Yes	No	Autonomous Mode Timing Configuration
09h	R/W	Yes	Yes	8	Yes	No	Aperture Settings (Auto) Configuration
0Ah	R/W	Yes	Yes	8	Yes	Yes	Auxiliary Measurement Configuration
0Bh	R/W	Yes	Yes	8	Yes	Yes (Note 2)	Operating Mode Configuration

Note 1: Both SPI and I²C interfaces use a 7-bit register address format. I²C interfaces should left-justify the 7-bit addresses given in Table 18 (e.g., to access register 0Bh use the command byte construction {000_1011_X}, where X is a don't care).

Note 2: Not all bits apply to the MAX11802/MAX11803. See the individual register definitions.

Table 19. Data Readback Command Summary

HEX*	ACCESS	AUTO-INCREMENT	DATA LENGTH	MAX11800/ MAX11801	MAX11802/ MAX11803	FUNCTION
AUTONOMOUS CONVERSION MODE READBACK COMMANDS						
50h	R	N	INF	Yes	No	Read next available FIFO data block
DIRECT CONVERSION MODE READBACK COMMANDS						
52h	R	Y	8	Yes	Yes	X MSB (direct conversion result)
53h	R	Y	8	Yes	Yes	X LSB (direct conversion result)
54h	R	Y	8	Yes	Yes	Y MSB (direct conversion result)
55h	R	Y	8	Yes	Yes	Y LSB (direct conversion result)
56h	R	Y	8	Yes	Yes	Z1 MSB (direct conversion result)
57h	R	Y	8	Yes	Yes	Z1 LSB (direct conversion result)
58h	R	Y	8	Yes	Yes	Z2 MSB (direct conversion result)
59h	R	Y	8	Yes	Yes	Z2 LSB (direct conversion result)
5Ah	R	Y	8	Yes	Yes	AUX MSB (direct conversion result)
5Bh	R	N	8	Yes	Yes	AUX LSB (direct conversion result)

*Both SPI and I²C interfaces use a 7-bit register address format. I²C interfaces should left-justify the 7-bit addresses given in Table 19 (e.g., to access register 50h, use the command byte construction {101_0000_X}, where X is a don't care).

Low-Power, Ultra-Small Resistive Touch-Screen Controllers with I²C/SPI Interface

Table 20. Conversion Command Summary

HEX (NOTE 1)	R0 (CONT) (NOTE 2)	ACCESS	PAIRABLE	COMMAND LENGTH	MAX11800/ MAX11801	MAX11802/ MAX11803	FUNCTION
60h-67h	X	—	—	—	Yes	Yes	Reserved
69h	(1)	W	N	8	Yes	Yes	X panel setup
6Bh	(1)	W	N	8	Yes	Yes	Y panel setup
6Dh	(1)	W	N	8	Yes	Yes	Z1 panel setup
6Fh	(1)	W	N	8	Yes	Yes	Z2 panel setup
70h	(0)	W	N	8	Yes	Yes	X, Y combined command
72h	(0)	W	N	8	Yes	Yes	X, Y, Z1 combined command
74h	(0)	W	N	8	Yes	Yes	X, Y, Z1, Z2 Combined command
76h	(0)	W	N	8	Yes	Yes	AUX conversion
78h	CONT = 0	W	N	8	Yes	Yes	X measurement
79h	CONT = 1	W	N	8	Yes	Yes	X measurement
7Ah	CONT = 0	W	N	8	Yes	Yes	Y measurement
7Bh	CONT = 1	W	N	8	Yes	Yes	Y measurement
7Ch	CONT = 0	W	N	8	Yes	Yes	Z1 measurement
7Dh	CONT = 1	W	N	8	Yes	Yes	Z1 measurement
7Eh	CONT = 0	W	N	8	Yes	Yes	Z2 measurement
7Fh	CONT = 1	W	N	8	Yes	Yes	Z2 measurement

Note 1: Both SPI and I²C interfaces use a 7-bit register address format. I²C interfaces should left-justify the 7-bit addresses given in Table 20 (e.g., to access register 50h use the command byte construction {101_0000_X}, where X is a don't care).

Note 2: R0 bit is forced to 1 for panel setup commands, and forced to 0 for combined and AUX commands. For measurement commands it is user selectable. CONT = 0 means perform a measurement without continuation, while CONT = 1 means perform a measurement with continuation. Continuation mode maintains the present panel setup conditions after the conclusion of the measurement, and can be useful when performing multiple measurements of the same type.

Panel Setup and Measurement Commands

TSC conversion commands are only to be used in direct conversion mode (AUTO = 0). Conversion commands issued during autonomous mode are ignored. All panel setup and measurement operations are automated when in autonomous mode (AUTO = 1).

Commands must be issued in write mode to be executed. There are two types of commands: panel setup registers (0x6x) and measurement/conversion registers (0x7x). All measurement commands indicate that the ADC is used and the ADC can begin to power up once the 0x7x header has been recognized. All measurement commands modify the target data register upon the conclusion of the measurement command. The

CONT bit impacts the setup of the panel and ADC following the command. For panel setup commands and combined commands, the user setting of this bit (R0) is ignored. For these commands, the internal assumption is shown in parentheses in Table 22.

The CONT bit impacts the setup of the panel and/or ADC following the command (see command descriptions for details). For some commands, the user setting of this bit (R0) is ignored; for these commands the internal assumption is shown in parentheses in Tables 8 and 22.

By definition, panel setup and measurement commands are NOT pairable in write mode as each command modifies the panel setting both during the command and after it (based on conversion executions and CONT bit settings).

Low-Power, Ultra-Small Resistive Touch-Screen Controllers with I²C/SPI Interface

MAX11800-MAX11803

Table 21. Measurement Commands

HEX	ACCESS	PAIRABLE	COMMAND LENGTH	FUNCTION
0x70h	Write	No	8	X, Y = combined command measurement
0x72h	Write	No	8	X, Y, Z1 = combined command measurement
0x74h	Write	No	8	X, Y, Z1, Z2 = combined command measurement
0x76h	Write	No	8	AUX = conversion
0x78h	Write	No	8	X = measurement, CONT = 0
0x79h	Write	No	8	X = measurement, CONT = 1
0x7Ah	Write	No	8	Y = measurement, CONT = 0
0x7Bh	Write	No	8	Y = measurement, CONT = 1
0x7Ch	Write	No	8	Z1 = measurement, CONT = 0
0x7Dh	Write	No	8	Z1 = measurement, CONT = 1
0x7Eh	Write	No	8	Z2 = measurement, CONT = 0
0x7Fh	Write	No	8	Z2 = measurement, CONT = 1

User Configuration Registers

General Status Register (0x00) (Read Only)

BIT	7	6	5	4	3	2	1	0
NAME	ADC_BUSY	LPM	TDM	SCAN	FIFO_OVR	FIFO_INT	EDGE_INT	CONT_INT
DEFAULT	0	0	0	0	0	0	0	0
BIT	NAME	DESCRIPTION	MAX11800/ MAX11801	MAX11802/ MAX11803				
7	ADC_BUSY	0: ADC is not in ACQ or CONV state 1: ADC is in ACQ or CONV state This is for INTERNAL TEST only	Yes	Yes				
6	LPM	0: Device is not in LPM or standby mode 1: Device is in LPM or standby mode	Yes	Yes				
5	TDM	0: Device is not in TDM mode 1: Device is in TDM mode	Yes	Yes				
4	SCAN	0: No scan or measurement in progress 1: Scan or measurement in progress Also indicates presence of a continuous touch in autonomous	Yes	Yes				
3	FIFO_OVR	0: FIFO overflow has not occurred 1: FIFO has overflowed since last readback operation Enabled only if AUTO = 1	Yes	No				
2	FIFO_INT	0: No unread data in FIFO 1: New data available in FIFO Enabled only if AUTO = 1	Yes	No				
1	EDGE_INT	0: No touch event in progress 1: Touch event in progress (cleared on ETAG = 10) Enabled only if AUTO = 0 and EDGE_IRQ = 1	Yes	Yes				
0	CONT_INT	0: No touch present 1: Touch present (or conversion in progress) Enabled only if AUTO = 0 and EDGE_IRQ = 0	Yes	Yes				

Low-Power, Ultra-Small Resistive Touch-Screen Controllers with I²C/SPI Interface

General Configuration Register (0x01)

BIT	7	6	5	4	3	2	1	0
NAME	RT_SEL	HOLD_DO	PU_IRQ	ODN_IRQ	MASK_IRQ	EDGE_IRQ	EDGE_TIME[1:0]	
DEFAULT	1	1	1	1	0	0	0	0

BIT	NAME	DESCRIPTION	MAX11800/ MAX11801	MAX11802/ MAX11803
7	RT_SEL	0: 50kΩ touch-detection pullup resistance 1: 100kΩ touch-detection pullup resistance (panel setting—not to be confused with internal \overline{TIRQ} pullup)	Yes	Yes
6	HOLD_DO	0: DOUT internal bus holder disabled 1: DOUT internal bus holder enabled (applicable to SPI version only)	Yes	Yes
5	PU_IRQ	0: Disable IRQ internal pullup resistance 1: Enable IRQ internal pullup resistance (open-drain mode only: ODN_IRQ also high)	Yes	Yes
4	ODN_IRQ	0: \overline{TIRQ} is CMOS buffered output 1: \overline{TIRQ} is open-drain nMOS output	Yes	Yes
3	MASK_IRQ	0: Enable \overline{TIRQ} output 1: Mask/disable \overline{TIRQ} output (force high or high-z)	Yes	Yes
2	EDGE_IRQ	0: Use continuous interrupt with direct conversion mode 1: Use edge interrupt with direct conversion mode	Yes	Yes
1:0	EDGE_TIME[1:0]	\overline{TIRQ} low time for edge interrupt mode only 00: 4 x (2MHz oscillator clock period) = 2μs 01: 16 x (2MHz oscillator clock period) = 8μs 10: 64 x (2MHz oscillator clock period) = 32μs 11: 128 x (2MHz oscillator clock period) = 128μs	Yes	Yes

Measurement Resolution Configuration Register (0x02)

BIT	7	6	5	4	3	2	1	0
NAME	—	—	—	PWR_SAV	RESX	RESY	RESZ1	RESZ2
DEFAULT	0	0	0	0	0	0	0	0

BIT	NAME	DESCRIPTION	MAX11800/ MAX11801	MAX11802/ MAX11803
4	PWR_SAV	0: Internal ADC runs at normal power 1: Internal ADC runs at reduced power and resolution This mode does limit the effective ADC resolution: 12-bit conversions can be reduced to 10-bit accuracy 8-bit conversions should not be impacted	Yes	Yes
3:0	RES_	Resolution for X, Y, Z1, or Z2 measurements 0: 12-bit conversion (see the PWR_SAV description in this table) 1: 8-bit conversion	Yes	Yes

Low-Power, Ultra-Small Resistive Touch-Screen Controllers with I²C/SPI Interface

MAX11800-MAX11803

Measurement Averaging Configuration Register (0x03)*

BIT	7	6	5	4	3	2	1	0	
NAME	AVG_X[1:0]		AVG_Y[1:0]		AVG_Z1[1:0]		AVG_Z2[1:0]		
DEFAULT	0	0	0	0	0	0	0	0	
BIT	NAME	DESCRIPTION				MAX11800/ MAX11801	MAX11802/ MAX11803		
7:6	AVG_X[1:0]	Averaging sample depth for X, Y, Z1, or Z2 measurements If AVG_FLT = 0 (see the <i>Operating Mode Configuration Register (0x0B)</i> section)				Yes	Yes		
5:4	AVG_Y[1:0]	00: Single sample, no averaging 01: Take four samples, average two median samples 10: Take eight samples, average four median samples 11: Take 16 samples, average eight median samples				Yes	Yes		
3:2	AVG_Z1[1:0]	If AVG_FLT = 1 (see the <i>Operating Mode Configuration Register (0x0B)</i> section) 00: Single sample, no averaging 01: Take four samples, average all samples 10: Take eight samples, average all samples 11: Take 16 samples, average all samples				Yes	Yes		
1:0	AVG_Z2[1:0]					Yes	Yes		

*The settings can be enabled and disabled through settings in the operating mode configuration register (0x0B), allowing for dynamic configuration of averaging modes depending on operating mode.

ADC Sampling Time Configuration Register (0x04)*

BIT	7	6	5	4	3	2	1	0	
NAME	T_SAMPLE_X[1:0]		T_SAMPLE_Y[1:0]		T_SAMPLE_Z1[1:0]		T_SAMPLE_Z2[1:0]		
DEFAULT	0	0	0	0	0	0	0	0	
BIT	NAME	DESCRIPTION				MAX11800/ MAX11801	MAX11802/ MAX11803		
7:6	T_SAMPLE_X[1:0]	Sampling time for X, Y, Z1 or Z2 measurements 00: 4 x (2MHz oscillator clock period) = 2µs 01: 16 x (2MHz oscillator clock period) = 8µs 10: 64 x (2MHz oscillator clock period) = 32µs 11: 256 x (2MHz oscillator clock period) = 128µs				Yes	Yes		
5:4	T_SAMPLE_Y[1:0]					Yes	Yes		
3:2	T_SAMPLE_Z1[1:0]					Yes	Yes		
1:0	T_SAMPLE_Z2[1:0]					Yes	Yes		

*Time ADC spends sampling panel before starting conversion process. This time plus the ADC conversion time determines the sampling rate within averaging operations. Be sure to allow adequate time to settle the ADC capacitors given the panel effective source resistance.

Low-Power, Ultra-Small Resistive Touch-Screen Controllers with I²C/SPI Interface

Panel Setup Timing Configuration Register (0x05)

BIT	7	6	5	4	3	2	1	0
NAME	PSUXY[3:0]				PSUZ[3:0]			
DEFAULT	0	0	0	0	0	0	0	0
BIT	NAME	DESCRIPTION	MAX11800/ MAX11801	MAX11802/ MAX11803				
7:4	PSUXY[3:0]	X, Y panel setup times (position measurements) 0000: 0µs 1000: 1ms 0001: 20µs 1001: 2ms 0010: 50µs 1010: 5ms 0011: 80µs 1011: 10ms 0100: 100µs 1100: 20ms 0101: 200µs 1101: 50ms 0110: 500µs 1110: 100ms 0111: 800µs 1111: 200ms	Yes	Yes				
3:0	PSUZ[3:0]	Z panel setup times (pressure measurements) PSUZ[3:0] has the same range as PSUXY[3:0] above.	Yes	Yes				

Note: These settings apply to measurement commands, combined commands, and autonomous conversion mode measurements and provide time for the panel to settle prior to beginning measurements. During these periods, the panel is set up, but the ADC remains powered down. Users with low-impedance/fast settling panels should use setting 0000 (skip mode) if their panel can be settled during the required 10µs minimum delayed conversion time (see the Delayed Conversion Configuration Register (0x06) section).

Delayed Conversion Configuration Register (0x06)

BIT	7	6	5	4	3	2	1	0
NAME	D_CV_XY[3:0]				D_CV_Z[3:0]			
DEFAULT	0	0	0	0	0	0	0	0
BIT	NAME	DESCRIPTION	MAX11800/ MAX11801	MAX11802/ MAX11803				
7:4	D_CV_XY[3:0]	X, Y panel plus ADC setup times (position measurements) 0000: 10µs 1000: 1ms 0001: 20µs 1001: 2ms 0010: 50µs 1010: 5ms 0011: 80µs 1011: 10ms 0100: 100µs 1100: 20ms 0101: 200µs 1101: 50ms 0110: 500µs 1110: 100ms 0111: 800µs 1111: 200ms	Yes	Yes				
3:0	D_CV_Z[3:0]	Z panel plus ADC setup times (pressure measurements) D_CV_Z[3:0] has the same range as D_CV_XY[3:0] above.	Yes	Yes				

Note: These settings apply to measurement commands, combined commands, and autonomous conversion mode measurements and provide time for the panel and ADC to settle prior to beginning measurements. During these periods, the panel is set up and the ADC is powered up. In general, users with long panel settling requirements should minimize time in this mode, using increased panel setup times instead to save ADC power.

Low-Power, Ultra-Small Resistive Touch-Screen Controllers with I²C/SPI Interface

MAX11800-MAX11803

Touch-Detect Pullup Timing Configuration Register (0x07)

BIT	7	6	5	4	3	2	1	0
NAME	PUR[3:0]				PUF[3:0]			
DEFAULT	0	0	0	0	0	0	0	0
BIT	NAME	DESCRIPTION				MAX11800/ MAX11801	MAX11802/ MAX11803	
7:4	PUR[3:0]	Rough pullup time (t _{PUR}) 0000: 2μs* 1000: 1ms 0001: 2μs 1001: 2ms 0010: 4μs 1010: 5ms 0011: 8μs 1011: 10ms 0100: 10μs 1100: 20ms 0101: 50μs 1101: 50ms 0110: 100μs 1110: 100ms 0111: 500μs 1111: 200ms				Yes	Yes	
3:0	PUF[3:0]	Fine pullup time (t _{PUF}) 0000: 10μs 1000: 1ms 0001: 20μs 1001: 2ms 0010: 50μs 1010: 5ms 0011: 80μs 1011: 10ms 0100: 100μs 1100: 20ms 0101: 200μs 1101: 50ms 0110: 500μs 1110: 100ms 0111: 800μs 1111: 200ms				Yes	Yes	

Note: These settings apply to the end of all measurement and combined commands and are required for proper data tagging and interrupt management. The exception is direct conversion commands with CONT = 1. These commands do not enter PUR/PUF intervals for the purpose of data tagging.

*While 2μs is the minimum PUR interval listed, for this setting, the XPSW is not engaged, allowing for minimal power operation (essentially adding 2μs to the PUF time).

Low-Power, Ultra-Small Resistive Touch-Screen Controllers with I²C/SPI Interface

Autonomous Mode Timing Configuration Register (0x08)

BIT	7	6	5	4	3	2	1	0
NAME	TINIT[3:0]				SCANP[3:0]			
DEFAULT	0	0	0	0	0	0	0	0
BIT	NAME	DESCRIPTION	MAX11800/ MAX11801	MAX11802/ MAX11803				
7:4	TINIT[3:0]	Initial period (time between touch and initial scan block, t_{INIT}) 0000: 10 μ s 1000: 1ms 0001: 20 μ s 1001: 2ms 0010: 50 μ s 1010: 5ms 0011: 80 μ s 1011: 10ms 0100: 100 μ s 1100: 20ms 0101: 200 μ s 1101: 50ms 0110: 500 μ s 1110: 100ms 0111: 800 μ s 1111: 200ms	Yes	No				
3:0	SCANP[3:0]	Scan period (time between successive scan blocks, t_{SP}) SCANP[3:0] has the same range as TINIT[3:0] above.	Yes	No				

Note: These settings apply in autonomous conversion mode only.

Aperture Configuration Register (0x09)

BIT	7	6	5	4	3	2	1	0
NAME	APRX[3:0]				APRY[3:0]			
DEFAULT	0	0	0	0	0	0	0	0
BIT	NAME	DESCRIPTION	MAX11800/ MAX11801	MAX11802/ MAX11803				
7:4	APRX[3:0]	$\pm\Delta X$ for aperture checking 0000 = 2^{-1} LSB = aperture checking disabled 0001 = $2^{(1-1)}$ LSB = ± 1 LSB 0010 = $2^{(2-1)}$ LSB = ± 2 LSB 0011 = $2^{(3-1)}$ LSB = ± 4 LSB . . . 1001 = $2^{(9-1)}$ LSB = ± 256 LSB 1010 = $2^{(10-1)}$ LSB = ± 512 LSB 1011 = $2^{(11-1)}$ LSB = ± 1024 LSB 1100 = $2^{(12-1)}$ LSB = ± 2048 LSB ≥ 1101 = N/A = aperture checking disabled	Yes	No				
3:0	APRY[3:0]	$\pm\Delta Y$ for aperture checking APRY[3:0] has the same range as APRX[3:0] above.	Yes	No				

Note: These aperture settings apply in autonomous conversion mode only and control whether data meets the criteria for logging into the FIFO.

Low-Power, Ultra-Small Resistive Touch-Screen Controllers with I²C/SPI Interface

MAX11800-MAX11803

Auxiliary Measurement Configuration Register (0x0A)

BIT	7	6	5	4	3	2	1	0
NAME	D_CV_A[3:0]			T_SAMPLE_A[1:0]		AVGA[1:0]		RESA
DEFAULT	0	0	0	0	0	0	0	0
BIT	NAME	DESCRIPTION				MAX11800/ MAX11801	MAX11802/ MAX11803	
7:5	D_CV_A[3:0]	Delay initial auxiliary conversion 000: 10μs 001: 100μs 010: 500μs 011: 1ms 100: 5ms 101: 10ms 110: 50ms 111: 100ms				Yes	Yes	
4:3	T_SAMPLE_A[1:0]	Sampling time for auxiliary measurements 00: 4 x (2MHz oscillator clock period) = 2μs 01: 16 x (2MHz oscillator clock period) = 8μs 10: 64 x (2MHz oscillator clock period) = 32μs 11: 256 x (2MHz oscillator clock period) = 128μs				Yes	Yes	
2:1	AVGA[1:0]	Averaging sample depth for auxiliary measurements If AVG_FLT = 0 (see the <i>Operating Mode Configuration Register (0x0B)</i> section) 00: Single sample, no averaging 01: Take four samples, average two median samples 10: Take eight samples, average four median samples 11: Take 16 samples, average eight median samples If AVG_FLT = 1 (see the <i>Operating Mode Configuration Register (0x0B)</i> section) 00: Single sample, no averaging 01: Take four samples, average all samples 10: Take eight samples, average all samples 11: Take 16 samples, average all samples				Yes	Yes	
0	RESA	Resolution for auxiliary measurements 0: 12-bit conversion (see the description of PWR_SAV in the <i>Measurement Resolution Configuration Register (0x02)</i> section) 1: 8-bit conversion				Yes	Yes	

Note: A delimiter refers to the auxiliary input (AUX). Auxiliary measurements can only be requested in direct conversion modes.

Low-Power, Ultra-Small Resistive Touch-Screen Controllers with I²C/SPI Interface

Operating Mode Configuration Register (0x0B)

BIT	7	6	5	4	3	2	1	0
NAME	PWRDN	AMODE[1:0]		APER	AVG_FLT	EN_AVG_XY	EN_AVG_Z	—
DEFAULT	1	0	0	0	0	0	0	0
BIT	NAME	DESCRIPTION			MAX11800/ MAX11801	MAX11802/ MAX11803		
7	PWRDN	0: Device is powered up and operational in either a direct or autonomous conversion mode (see AMODE[1:0] below). 1: Device is powered down, OTP is held in reset			Yes	Yes		
6:5	AMODE[1:0]	00: Direct conversion mode (AUTO = 0) 01: Autonomous X and Y scan (AUTO = 1) 10: Autonomous X, Y, Z1 scan (AUTO = 1) 11: Autonomous X, Y, Z1, Z2 scan (AUTO = 1)			Yes	No		
4	APER	0: Disregard aperture criteria 1: Enable aperture criteria (spatial filter) (applies to autonomous modes only)			Yes	No		
3	AVG_FLT	0: Use median averaging filters (ignore outliers) 1: Use straight averaging filters			Yes	Yes		
2	EN_AVG_XY	0: Disable (X, Y) position averaging in selected mode 1: Enable (X, Y) position averaging in selected mode			Yes	Yes		
1	EN_AVG_Z	0: Disable (Z1, Z2) pressure averaging in selected mode 1: Enable (Z1, Z2) pressure averaging in selected mode			Yes	Yes		
0	—	Reserved			—	—		

Low-Power, Ultra-Small Resistive Touch-Screen Controllers with I²C/SPI Interface

MAX11800/MAX11802 Typical Operating Circuit

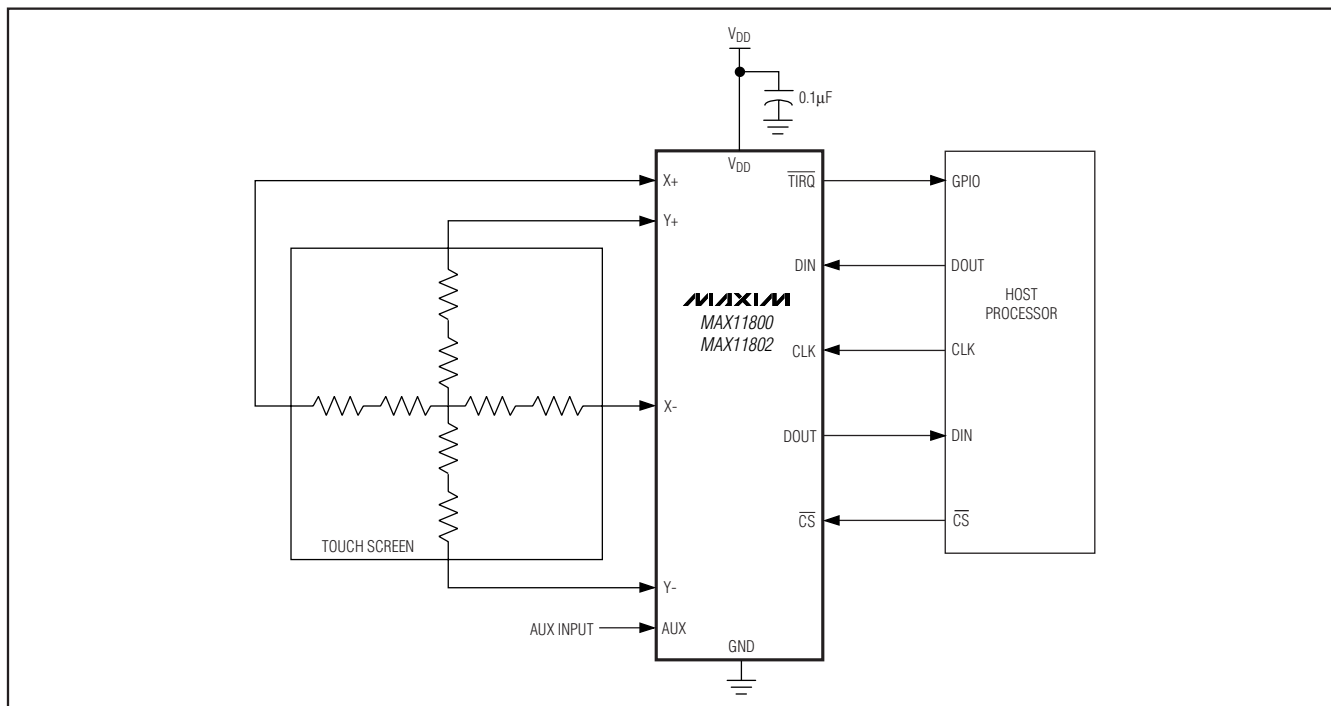

MAX11800-MAX11803

MAX11801/MAX11803 Typical Operating Circuit

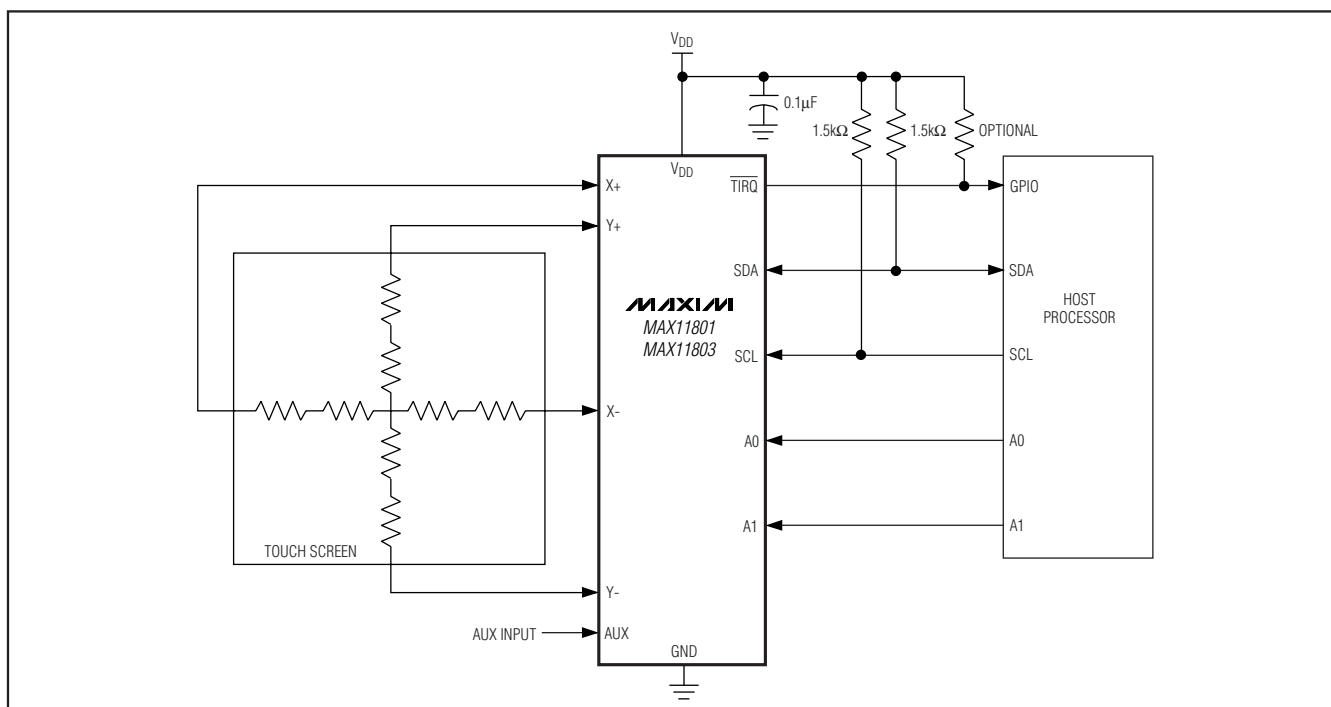

Low-Power, Ultra-Small Resistive Touch-Screen Controllers with I²C/SPI Interface

Pin Configurations

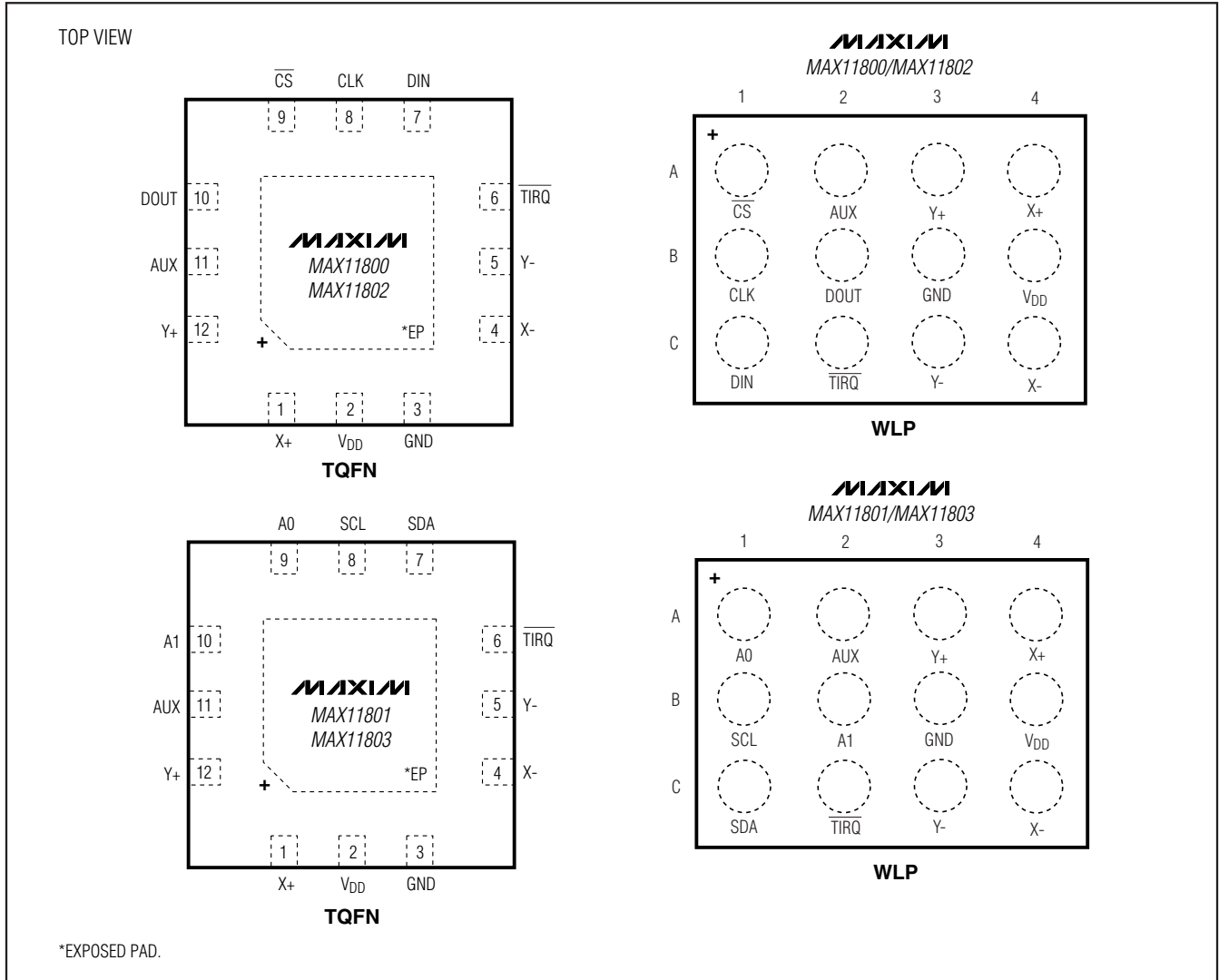

Chip Information

PROCESS: CMOS

Package Information

For the latest package outline information and land patterns, go to www.maxim-ic.com/packages. Note that a "+", "#", or "-" in the package code indicates RoHS status only. Package drawings may show a different suffix character, but the drawing pertains to the package regardless of RoHS status.

PACKAGE TYPE	PACKAGE CODE	OUTLINE NO.	LAND PATTERN NO.
12 TQFN	T1244+4	21-0139	90-0068
12 WLP	W121A2+1	21-0009	Refer to Application Note 1891

Low-Power, Ultra-Small Resistive Touch-Screen Controllers with I²C/SPI Interface

Revision History

REVISION NUMBER	REVISION DATE	DESCRIPTION	PAGES CHANGED
0	7/09	Initial release	—
1	11/09	Removed future status from the WLP packages in the <i>Ordering Information</i> table.	1
		Added a new Note 1 about the WLP package to the <i>Absolute Maximum Ratings</i> section.	8
		Corrected the pin names for the WLP packages in the <i>Pin Description</i> table and <i>Pin Configurations</i> .	14, 56
2	3/10	Added "Soldering Temperature (reflow) at +260°C." in the <i>Absolute Maximum Ratings</i> section.	8
3	10/10	Added information to differentiate the MAX11800/MAX11801 features and operating modes from the MAX11802/MAX11803 features and operating modes.	All

MAX11800-MAX11803

Maxim cannot assume responsibility for use of any circuitry other than circuitry entirely embodied in a Maxim product. No circuit patent licenses are implied. Maxim reserves the right to change the circuitry and specifications without notice at any time.

Maxim Integrated Products, 120 San Gabriel Drive, Sunnyvale, CA 94086 408-737-7600 _____ 59