

阅读申明

- 1.本站收集的数据手册和产品资料都来自互联网，版权归原作者所有。如读者和版权方有任何异议请及时告之，我们将妥善解决。
- 2.本站提供的中文数据手册是英文数据手册的中文翻译，其目的是协助用户阅读，该译文无法自动跟随原稿更新，同时也可能存在翻译上的不当。建议读者以英文原稿为参考以便获得更精准的信息。
- 3.本站提供的产品资料，来自厂商的技术支持或者使用者的心得体会等，其内容可能存在描述上的差异，建议读者做出适当判断。
- 4.如需与我们联系，请发邮件到marketing@iczoom.com，主题请标有“数据手册”字样。

Read Statement

1. The datasheets and other product information on the site are all from network reference or other public materials, and the copyright belongs to the original author and original published source. If readers and copyright owners have any objections, please contact us and we will deal with it in a timely manner.
2. The Chinese datasheets provided on the website is a Chinese translation of the English datasheets. Its purpose is for reader's learning exchange only and do not involve commercial purposes. The translation cannot be automatically updated with the original manuscript, and there may also be improper translations. Readers are advised to use the English manuscript as a reference for more accurate information.
3. All product information provided on the website refer to solutions from manufacturers' technical support or users the contents may have differences in description, and readers are advised to take the original article as the standard.
4. If you have any questions, please contact us at marketing@iczoom.com and mark the subject with "Datasheets" .



FUSB301

Autonomous USB Type-C Controller with Super Speed Switch Control

Features

- Fully Autonomous Type-C Controller
- Supports Type-C Versions 1.1 and 1.0
- V_{DD} Operating Range, 3.0 V- 5.5 V
- Low Disable Power: I_{CC} = 2 μ A (Max.)
- Low Standby Power: I_{CC} = 7 μ A (Max.)
- Dual Role Port Mode with Optional Accessory Support
- Capable of Supporting Try.SNK and Try.SRC
- Super Speed Switch Control
- Dead Battery Support (Sink Mode Support when No Power Applied)
- 2 kV HBM ESD Protection
- Small Packaging, 10 Lead TMLP (1.6 mm x 1.2 mm x 0.375 mm)

Description

The FUSB301 is a fully autonomous Type-C controller optimized for <15 W applications. The FUSB301 offers CC logic detection for Source Mode, Sink Mode, Dual Role Port Mode, accessory detection support, and dead battery support. The FUSB301 features an external switch pin (SS_SW) to enable an external USB Super Speed Switch without interrupting the processor. The FUSB301 features an extremely low power disable mode as well as low power during normal operation. It is available in an ultra thin, 10-Lead TMLP package.

Applications

- Smartphones
- Tablets
- Notebooks
- Ultra Portable Applications

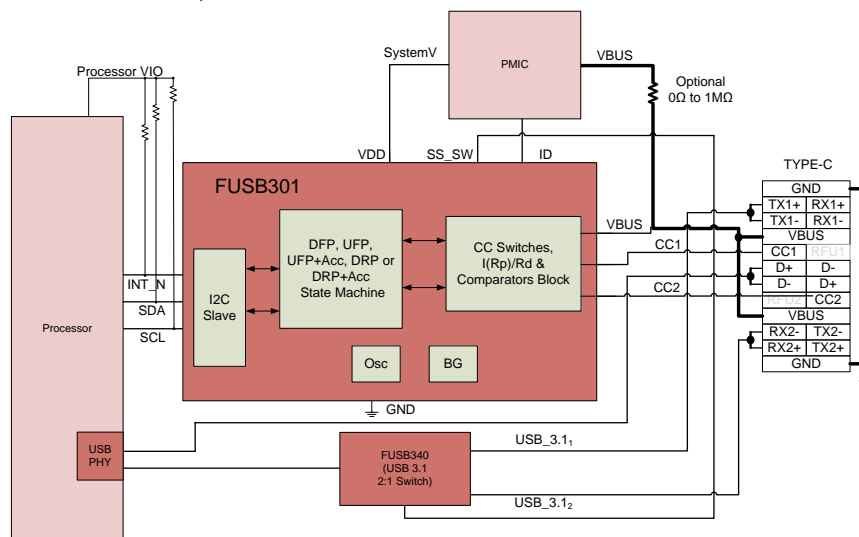

Figure 1. Typical Application

Ordering Information

Part Number	Top Mark	Operating Temperature Range	Package	Packing Method
FUSB301TMX	NU	-40 to 85°C	10-Lead Ultra-thin Molded Leadless Package (TMLP) 1.6 mm x 1.2 mm x 0.375 mm	Tape and Reel

Block Diagram

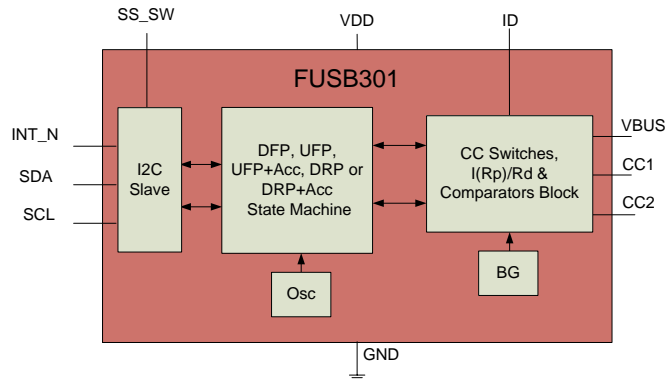

Figure 2. Block Diagram

Pin Configuration

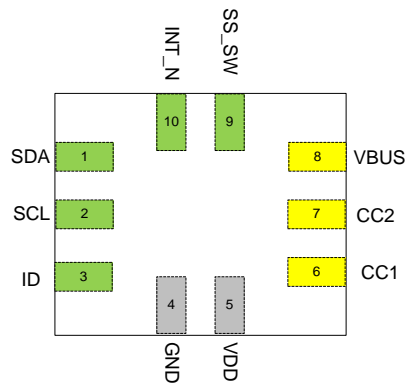

Figure 3. Pin Assignment (Top Through View)

Pin Descriptions

Pin #	Name	Type	Description
USB Type-C Connector Interface			
6, 7	CC1, CC2	I/O	Type-C Configuration Channel
8	VBUS	Input	VBUS input pin for attach and detach detection
4	GND	Ground	Ground
Power Interface			
5	VDD	Power	Input Supply Voltage
Signal Interface			
1	SDA	Input	I ² C serial data signal to be connected to the I ² C master
2	SCL	Open-Drain I/O	I ² C serial clock signal to be connected to the I ² C master.
3	ID	Open Drain Output	Used to Identify if connected device is Source or Sink. The ID Pin can be used to interface with USB2.0 Input on the processor.
9	SS_SW	CMOS Output	External Super Speed Switch control without processor interrupt.
10	INT_N	Open Drain Output	Active Low open drain interrupt output used to prompt processor to read I ² C register bits

Dead Battery

If power is not applied to FUSB301 and it is attached to a Source device, then the Source would pull up the CC line connected through the cable. The FUSB301 in response would turn on the pull-down that will bring the CC voltage to a range that the Source can detect an attach and turn on VBUS.

Power Up, Initialization and Reset, Interrupt Operation

When power is first applied, the FUSB301 will power up in Sink mode with all interrupts masked. The local processor must configure the FUSB301 to the desired mode and clear the global interrupt mask bit, INT_MASK. The INT_N pin is an active low, open drain output. This pin indicates to the host processor that an interrupt has occurred in the FUSB301 which needs attention. The INT_N pin is in a high impedance state by default after power-up or device reset, and the global interrupt mask (INT_MASK in Control register) is set. After INT_MASK bit is cleared by the local processor, the INT_N pin stays high impedance in preparation of

future interrupts. When an interruptible event occurs, INT_N is driven LOW and is in a high impedance state again when the processor clears the interrupt by reading the interrupt registers. Subsequent to the initial power up or reset; if the processor writes a “1” to global interrupt mask bit when the system is already powered up, the INT_N pin stays in a high impedance state and ignores all interrupts until the global interrupt mask bit is cleared. If an event happens that would ordinarily cause an interrupt when the global interrupt mask bit is set, the INT_N pin goes LOW when the global interrupt mask is cleared.

SuperSpeed Switch Control

For applications that require a SuperSpeed USB switch (USB3.1 Gen 1), the SS_SW pin will autonomously control the USB switch, such as the FUSB340TMX, without interrupting the processor.

Table 1. SuperSpeed Switch Truth Table

CC1	CC2	ORIENT1	ORIENT0	SS_SW
Not Connected	Not Connected	0	0	Low
Connected to CC		0	1	Low
	Connected to CC	1	0	High
Not Connected	Not Connected	1	1	Low

Table 2. ID Pin Truth Table

TYPE Register (h12, bit 4)	Description	ID
SINK = b0	SINK Not Detected	Hi-Z (default)
SINK = b1	SINK Detected	Low

Absolute Maximum Ratings

Stresses exceeding the absolute maximum ratings may damage the device. The device may not function or be operable above the recommended operating conditions and stressing the parts to these levels is not recommended. In addition, extended exposure to stresses above the recommended operating conditions may affect device reliability. The absolute maximum ratings are stress ratings only.

Symbol	Parameter		Min.	Max.	Unit
V _{DD}	Supply Voltage from V _{DD}		-0.5	6.0	V
V _{BUS}	VBUS Supply Voltage		-0.5	28	V
V _{CC_HDDRP}	CC pins when configured as Host, Device or Dual Role Port		-0.5	6.0	V
T _{STORAGE}	Storage Temperature Range		-65	+150	C
T _J	Maximum Junction Temperature			+150	C
T _L	Lead Temperature (Soldering, 10 Seconds)			+260	C
ESD	IEC 61000-4-2 System ESD	Connector Pins (VBUS, CC1 & CC2) Air Gap	15		kV
		Connector Pins (VBUS, CC1 & CC2) Contact	8		
	Human Body Model, JEDEC JESD22-A114	Connector Pins (VBUS, CC1 and CC2)	4		kV
		Others	2		
Charged Device Model, JEDEC LESD22-C101	All Pins	1			

Recommended Operating Conditions

The Recommended Operating Conditions table defines the conditions for actual device operation. Recommended operating conditions are specified to ensure optimal performance. Fairchild does not recommend exceeding them or designing to Absolute Maximum Ratings.

Symbol	Parameter	Min.	Typ.	Max.	Unit
V _{BUS}	VBUS Supply Voltage	3.7	5.0	21	V
V _{DD}	Supply Voltage	2.8 ⁽¹⁾	3.3	5.5	V
T _A	Operating Temperature	-40		+85	C

Note:

1. This is for functional operation only and isn't the lowest limit for all subsequent electrical specifications below. All electrical parameters have a minimum of 3 V operation.

DC and Transient Characteristics

Unless otherwise specified: Recommended T_A and T_J temperature ranges. All typical values are at $T_A=25^\circ\text{C}$ and $V_{DD}=3.3\text{ V}$ unless otherwise specified.

Symbol	Parameter	$T_A = -40\text{ to }+85^\circ\text{C}$ $T_J = -40\text{ to }+125^\circ\text{C}$			Unit
		Min.	Typ.	Max.	
Type C Specific Parameters					
I_{80_CCX}	Source 80 μA CC current (Default) HOST_CUR1=0, HOST_CUR0=1	64	80	96	μA
I_{180_CCX}	SOURCE 180 μA CC Current (1.5 A) HOST_CUR1=1, HOST_CUR0=0	166	180	194	μA
I_{330_CCX}	SOURCE 330 μA CC Current (3 A) HOST_CUR1=1, HOST_CUR0=1	304	330	356	μA
V_{SNKDB}	SINK Pull-Down Voltage in Dead Battery Under all Pull-up SOURCE Loads			2.18	V
R_{DEVICE}	Device Pull-Down Resistance when VDD is within Operating Range	4.6	5.1	5.6	k Ω
zOPEN	CC Resistance for Disabled State	126			k Ω
vRa-SRCdef	Ra Detection Threshold for CC Pin for Source for Default Current on VBUS	0.15	0.20	0.25	V
vRa-SRC1.5A	Ra Detection Threshold for CC Pin for Source for 1.5 A Current on VBUS	0.35	0.40	0.45	V
vRa-SRC3A	Ra Detection Threshold for CC Pin for Source for 3 A Current on VBUS	0.75	0.80	0.85	V
vRd-SRCdef	Rd Detection Threshold for Source for Default Current (HOST_CUR1/0=01)	1.50	1.60	1.65	V
vRd-SRC1.5A	Rd Detection Threshold for Source for 1.5 A Current (HOST_CUR1/0=10)	1.50	1.60	1.65	V
vRd-SRC3A	Rd Detection Threshold for Source for 3 A Current (HOST_CUR1/0=11)	2.45	2.60	2.75	V
vRa-SNK	Ra detection Threshold for CC Pin for Sink	0.15	0.20	0.25	V
vRd-def	Rd default Current Detection Threshold for Sink	0.61	0.66	0.70	V
vRd-1.5A	Rd 1.5 A Current Detection Threshold for Sink	1.16	1.23	1.31	V
vRd-3.0A	Rd 3 A Current Detection Threshold for Sink	2.04	2.11	2.18	V
vVBUSthr	VBUS Threshold at which I_VBUSOK Interrupt is Triggered	3.7			V

Current Consumption

Symbol	Parameter	V _{DD} (V)	Conditions	T _A = -40 to +85°C T _J = -40 to +125°C			Unit
				Min.	Typ.	Max.	
Idisable	Disabled Current	3.0 to 5.5	Disabled State		0.35	2.0	μA
Istby	Unattached Sink	3.0 to 5.5	Nothing Attached		3.5	7.0	μA
	Unattached Sink + Acc, Source + Acc, or DRP		Nothing Attached, Internally Toggling		5	20	μA
Iattach	Attach Current (Less Host Current)	3.0 to 5.5	Attached as a Sink		5	15	μA
			Attached as a Source		10	15	

Timing Parameters

Symbol	Parameter	T _A = -40 to +85°C T _J = -40 to +125°C			Unit	
		Min.	Typ.	Max.		
tCCDebounce	Debounce Time for CC (Source or Accessory)	100	150	200	ms	
	Debounce Time for CC (Sink)	63	75	87	ms	
tPDDebounce	Debounce Time for CC Detach Detection	10	15	20	ms	
tAccDetect	Debounce Time to Detect AudioAccessory, or DebugAccessory is Attached	50	100	200	ms	
tErrorRecovery	Time staying in the ErrorRecovery State if sent there via the ERROR_REC bit or by a change of Modes	25	50	100	ms	
tVBUSondeb	Debounce Time of VBUS Detection when acting as a Sink to Signal VBUS is present	0.167	0.200	0.375	ms	
tVBUSoffdeb	Debounce Time of VBUS Detection when acting as a Sink to Signal VBUS has been removed	10	15	20	ms	
tDRPToggle1	For DRP Operation, Time Spent in Unattached.Sink before going to Unattached.Source State	DRPTOGGLE=00	35		70	ms
		DRPTOGGLE=01	30		60	ms
		DRPTOGGLE=10	25		50	ms
		DRPTOGGLE=11	20		40	ms
tDRPToggle2	For DRP Operation, Time Spent in Unattached.Source before going to Unattached.Sink State	DRPTOGGLE=00	15		30	ms
		DRPTOGGLE=01	20		40	ms
		DRPTOGGLE=10	25		50	ms
		DRPTOGGLE=11	30		60	ms

IO Specifications

Symbol	Parameter	V _{DD} (V)	Conditions	T _A = -40 to +85°C T _J = -40 to +125°C			Unit
				Min.	Typ.	Max.	
Host Interface Pins (ID)							
V _{OLID}	Output Low Voltage	3.0 to 5.5	I _{OL} =4 mA			0.4	V
Host Interface Pins (SS_SW)							
V _{OHSW}	Output High Voltage	3.0 to 5.5	I _{OH} =-2 mA	0.7V _{DD}			V
V _{OLSW}	Output Low Voltage	3.0 to 5.5	I _{OL} =4 mA			0.4	V
Host Interface Pins (INT_N)							
V _{OLINTN}	Output Low Voltage	3.0 to 5.5	I _{OL} =4 mA			0.4	V
I²C Interface Pins – Fast Mode SDA, SCL)							
V _{IL12C}	Low-Level Input Voltage	3.0 to 5.5				0.4	V
V _{IH12C}	High-Level Input Voltage	3.0 to 5.5		1.2			V
V _{HYS}	Hysteresis of Schmitt Trigger Inputs	3.0 to 5.5		0.2			V
I _{12C}	Input Current of SDA and SCL Pins,	3.0 to 5.5	Input Voltage 0.26 V to 2 V	-10		10	μA
I _{CC12C}	VDD Current when SDA or SCL is HIGH	3.0 to 5.5	Input Voltage 1.8 V	-10		10	μA
V _{OLSDA}	Low-Level Output Voltage at 3 mA Sink Current (Open-Drain)	3.0 to 5.5		0		0.3	V
C _I	Capacitance for Each I/O Pin	3.0 to 5.5				10	pF

Fast Mode I2C Specifications (see Figure 4)

Symbol	Parameter	Fast Mode		
		Min.	Max.	Unit
f_{SCL}	I2C_SCL Clock Frequency	0	400	kHz
$t_{HD;STA}$	Hold Time (Repeated) START Condition	0.6		μ s
t_{LOW}	LOW Period of I2C_SCL Clock	1.3		μ s
t_{HIGH}	HIGH Period of I2C_SCL Clock	0.6		μ s
$t_{SU;STA}$	Set-up Time for Repeated START Condition	0.6		μ s
$t_{HD;DAT}$	Data Hold Time	0	0.9	μ s
$t_{SU;DAT}$	Data Set-up Time ⁽²⁾	100		ns
t_r	Rise Time of I2C_SDA and I2C_SCL Signals ⁽³⁾	$20*(V_{DD}/5.5 V)$	250	ns
t_f	Fall Time of I2C_SDA and I2C_SCL Signals ⁽³⁾	$20*(V_{DD}/5.5 V)$	250	ns
$t_{SU;STO}$	Set-up Time for STOP Condition	0.6		μ s
t_{BUF}	BUS-Free Time between STOP and START Conditions	1.3		μ s
t_{SP}	Pulse Width of Spikes that Must Be Suppressed by the Input Filter	0	50	ns

Notes:

- A fast-mode I²C-bus device can be used in a standard-mode I²C-bus system, but the requirement $t_{SU;DAT} \geq 250$ ns must be met. This is automatically the case if the device does not stretch the LOW period of the I2C_SCL signal. If such a device does stretch the LOW period of the I2C_SCL signal, it must output the next data bit to the I2C_SDA line $t_{r_max} + t_{SU;DAT} = 1000 + 250 = 1250$ ns (according to the standard-mode I2C bus specification) before the I2C_SCL line is released.
- C_b equals the total capacitance of one bus line in pF. If mixed with high-speed devices, faster fall times are allowed according to the I2C specification.

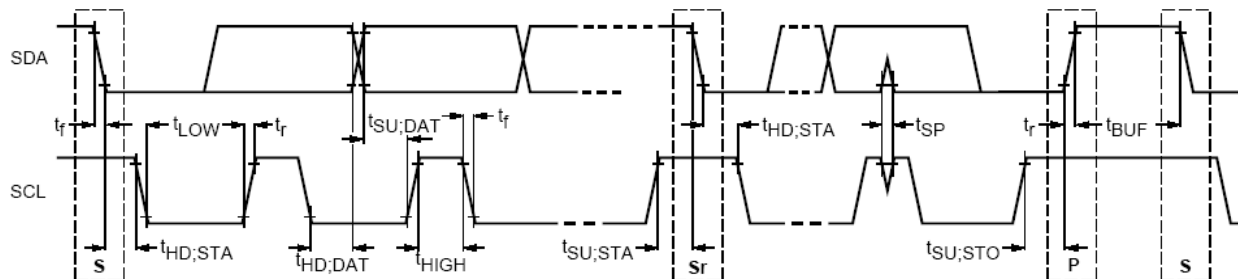
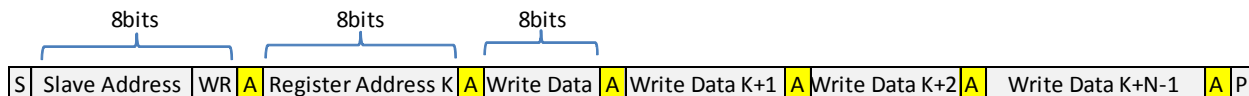

Figure 4. Definition of Timing for Full-Speed Mode Devices on the I²C Bus

I²C Interface

The FUSB301 includes a full I²C slave controller. The I²C slave fully complies with the I²C specification version 6 requirements. This block is designed for fast mode. Examples of an I²C write and read sequence are shown Figure 5 and Figure 6 respectively.



Note: Single Byte read is initiated by Master with P immediately following first data byte

Figure 5. I²C Write Example

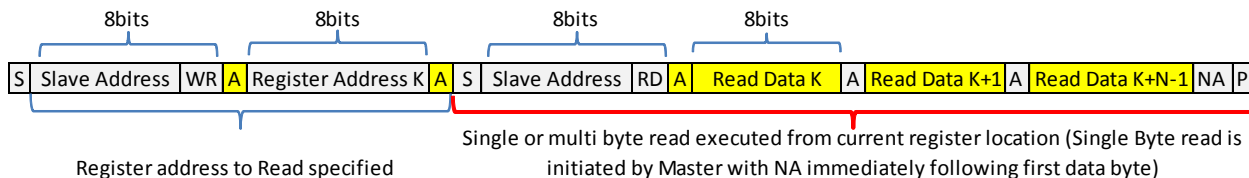

Note: If Register is not specified Master will begin read from current register. In this case only sequence showing in Red bracket is needed

From Master to Slave	S Start Condition	NA NOT Acknowledge (SDA High)	RD Read =1
From Slave to Master	A Acknowledge (SDA Low)	WR Write=0	P Stop Condition

Figure 6. I²C Read Example

I²C Address

Table 3. FUSB301 I²C Slave Address

Name	Size (Bits)	Bit 7	Bit 6	Bit 5	Bit 4	Bit 3	Bit 2	Bit 1	Bit 0
Slave Address	8	0	1	0	0	1	0	1	R/W

Register Definitions

Table 4. Register Map

Address	Register Name	Type	Rst Val	Bit7	Bit6	Bit5	Bit4	Bit3	Bit2	Bit1	Bit0
0x01	Device ID	RO	12	Version ID[3:0]				Revision ID[3:0]			
0x02	Modes	R/W	04			DRP+ACC	DRP	Sink+ACC	Sink	Source+ACC	Source
0x03	Control	R/W	03	DRPTOGGLE					HOST_CUR1	HOST_CUR0	INT_MASK
0x04	Manual	W/C	00					UNATT_SNK	UNATT_SRC	DISABLED	ERROR_REC
0x05	Reset	W/C	00								SW_RES
0x06-0x0F	Reserved	X	Xx	Do Not Use							
0x10	Mask	R/W	00					M_ACC_CH	M_BC_LVL	M_DETACH	M_ATTACH
0x11	Status	RO	00			ORIENT1	ORIENT0	VBUSOK	BC_LVL1	BC_LVL0	ATTACH
0x12	Type	RO	00				Sink	Source		DEBUGACC	AUDIOACC
0x13	Interrupt	R/C	00					I_ACC_CH	I_BC_LVL	I_DETACH	I_ATTACH
0x14-0x1F	Reserved	X	Xx	Do Not Use							

Notes:

4. Do not use registers that are blank
5. Values read from undefined register bits are invalid. Do not write to undefined registers.

Table 5. Device ID

Address: 01h

Reset Value: 0x0001_0010

Type: Read Only

Bit #	Name	Size (Bits)	Description
7:4	Version ID	4	Device version ID by Trim or etc. A_[Version ID]: 0001
3:0	Revision ID	4	Revision History of each version Revision ID]_revC: 0010

Table 6. Modes

Address: 02h

Reset Value: 0x0000_0100

Type: Read/Write

Bit #	Name	Size (Bits)	Description
7:6	Reserved	2	Do Not Use
5	DRP+ACC	1	1: Configure device as a Dual Role Port (DRP) with accessory support
4	DRP	1	1: Configure device as a Dual Role Port (DRP) without accessory support
3	Sink+ACC	1	1: Configure device as a Sink with accessory support
2	Sink	1	1: Configure device as a Sink without accessory support
1	Source+ACC	1	1: Configure device as a Source with accessory support
0	Source	1	1: Configure device as a Source without accessory support

Table 7. Control

Address: 03h

Reset Value: 0xXX00_X011

Type: Read/Write

Bit #	Name	Size (Bits)	Description
7:6	Reserved	2	Do Not Use
5:4	DRPTOGGLE	1	Selects different timing for Dual Role Port Toggle between Unattached.Sink State and Unattached.SOURCE State. 00: 35 ms min in Unattached. Sink and 15 ms min. in Unattached.SOURCE 01: 30 ms min. in Unattached.Sink and 20 ms min. in Unattached.SOURCE 10: 25 ms min. in Unattached.Sink and 25 ms min. in Unattached.SOURCE 11: 20 ms min. in Unattached.sink and 30 ms min. in Unattached.SOURCE
3	Reserved	1	Do Not Use
2:1	HOST_CUR[1:0]	2	1: Controls the pull-up current when device enabled as a Source 00: No Current 01: 80 μA – Default USB power 10: 180 μ A – Medium Current Mode: 1.5 A 11: 330 μ A – High Current Mode: 3 A
0	INT_MASK	1	1: Global interrupt mask to mask all interrupts

Table 8. Manual⁽⁶⁾

Address: 04h

Reset Value: 0xFFFF_0000

Type: Write/Clear

Bit #	Name	Size (Bits)	Description
7:4	Reserved	4	Do Not Use
3	UNATT_SNK	1	1: Put device in Unattached.Sink State as defined in the Type C spec
2	UNATT_SRC	1	1: Put device in Unattached.Source state as defined in the Type C spec
1	DISABLED ⁽⁷⁾	1	1: Put device in Disabled state as defined in the Type C spec
0	ERROR_REC	1	1: Put device in ErrorRecovery state as defined in the Type C spec

Notes:

- If more than one bit is set to “b1” simultaneously then an order of priority will be used. 1st priority is DISABLED, 2nd is ERROR_REC, 3rd is UNATT_SRC, last is UNATT_SNK. The highest priority bit will take precedence and all other bits will be cleared automatically.
- The DISABLED bit must be manually cleared.

Table 9. Reset

Address: 05h

Reset Value: 0xFFFF_XXX0

Type: Write/Clear

Bit #	Name	Size (Bits)	Description
7:6	Reserved	7	Do Not Use
0	SW_RES	1	1: Reset the system and I2C Register.

Table 10. Mask

Address: 10h

Reset Value: 0xFFFF_0000

Type: Read/Write

Bit #	Name	Size (Bits)	Description
7:4	Reserved	4	Do Not Use
3	M_ACC_CH	1	1: Mask a change from Accessory Present to Attached Accessory
2	M_BC_LVL	1	1: Mask a change in I_BC_LVL interrupt bit
1	M_DETACH	1	1: Mask the I_DETACH interrupt bit
0	M_ATTACH	1	1: Mask a change in the I_ATTACH interrupt bit

Table 11. Status

Address: 11h

Reset Value: 0xXX00_0000

Type: Read

Bit #	Name	Size (Bits)	Description
7:6	Reserved	2	Do Not Use
5:4	ORIENT[1:0]	2	Status to indicate which CCx pins has the CC cable connection 11: A fault has occurred during the detection 10: Cable CC is connected through the CC2 pin 01: Cable CC is connected through the CC1 pin 00: No or unresolved connection detected
3	VBUSOK	1	1: Status to indicate VBUS is in the valid range
2:1	BC_LVL[1:0]	2	Thresholds that allow detection of current advertisement on CC line 00: Ra or unattached Sink 01: Rd threshold for Sink default current advertisement 10: Rd threshold for Sink 1.5 A current advertisement 11: Rd threshold for Sink 3 A current advertisement
0	ATTACH	1	1: Attached to a device or accessory of a type shown in the Type register

Table 12. Type

Address: 12h

Reset Value: 0xXXX0_0X00

Type: Read

Bit #	Name	Size (Bits)	Description
7:5	Reserved	3	Do Not Use
4	Sink	1	1: Indicates a Sink has been detected
3	Source	1	1: Indicates a Source has been detected
2	Reserved	1	Do Not Use
1	DEBUGACC	1	1: Indicates a Debug Accessory has been detected
0	AUDIOACC	1	1: Indicates a Audio Accessory has been detected

Table 13. Interrupt0

Address: 13h

Reset Value: 0xXXXX_X000

Type: Write/Clear

Bit #	Name	Size (Bits)	Description
7:4	Reserved	5	Do Not Use
3	I_ACC_CH	1	1: Interrupt flagged when a change from Accessory Present to Audio Accessory or Debug Accessory occurs
2	I_BC_LVL	1	1: Interrupt flagged when a change in BC_LVL advertised current level has occurred
1	I_DETACH	1	1: Interrupt flagged when a device or accessory has been detached
0	I_ATTACH	1	1: Interrupt flagged when a device or accessory of type indicated in the Type register has been attached

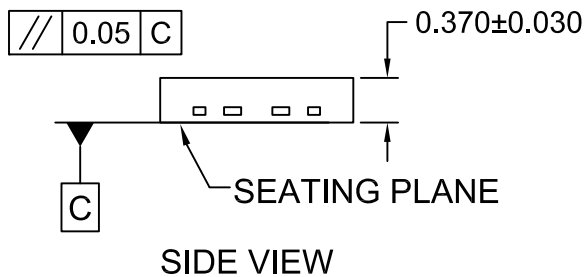
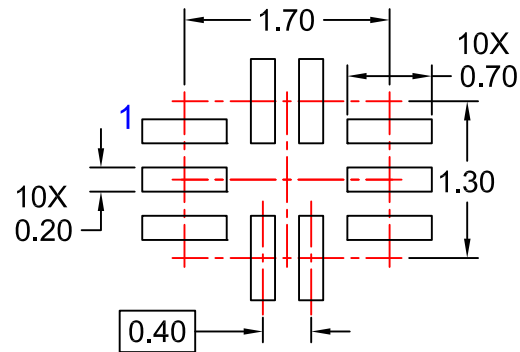
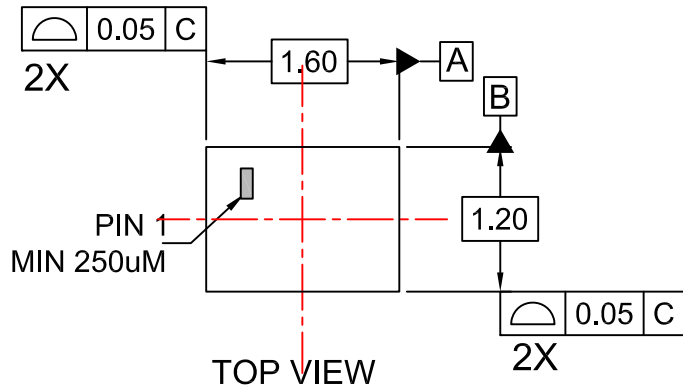

NOTES:



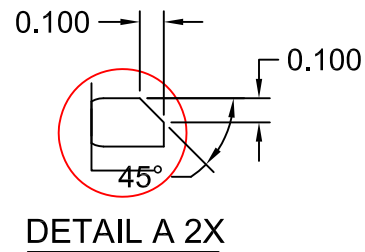
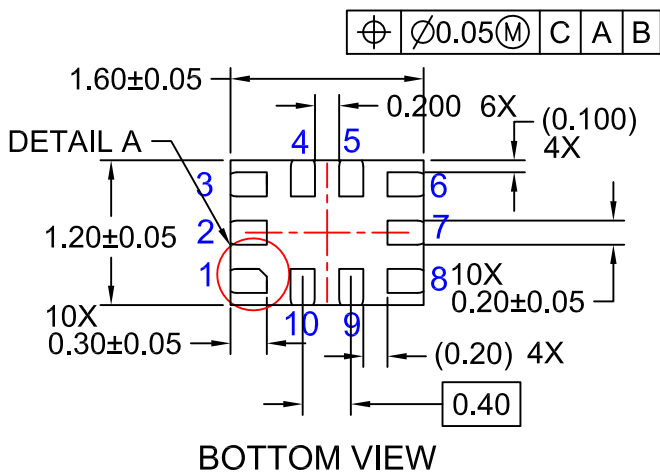

- A. NO JEDEC REGISTRATION APPLIES.
- B. DIMENSIONS ARE IN MILLIMETERS.
- C. DIMENSIONS AND TOLERANCE PER ASME Y14.5M, 2009.
- D. PACKAGE NOMINAL HEIGHT IS 370 MICRONS.
- E. FSC LANDPATTERN RECOMMENDATION
- F. DRAWING FILENAME: MKT-TMLP10Arev2





TRADEMARKS

The following includes registered and unregistered trademarks and service marks, owned by Fairchild Semiconductor and/or its global subsidiaries, and is not intended to be an exhaustive list of all such trademarks.

- AccuPower™
- AttitudeEngine™
- Awinda®
- AX-CAP®*
- BitSiC™
- Build it Now™
- CorePLUS™
- CorePOWER™
- CROSSVOL™
- CTL™
- Current Transfer Logic™
- DEUXPEED®
- Dual Cool™
- EcoSPARK®
- EfficientMax™
- ESBC™
- F**™
- Fairchild®
- Fairchild Semiconductor®
- FACT Quiet Series™
- FACT®
- FastvCore™
- FETBench™
- FPS™
- F-PFS™
- FRFET®
- Global Power ResourceSM
- GreenBridge™
- Green FPS™
- Green FPS™ e-Series™
- Gmax™
- GTO™
- IntelliMAX™
- ISOPLANAR™
- Making Small Speakers Sound Louder and Better™
- MegaBuck™
- MICROCOUPLER™
- MicroFET™
- MicroPak™
- MicroPak2™
- MillerDrive™
- MotionMax™
- MotionGrid®
- MTi®
- MTx®
- MVN®
- mWSaver®
- OptoHiT™
- OPTOLOGIC®
- OPTOPLANAR®
- ®
- Power Supply WebDesigner™
- PowerTrench®
- PowerXS™
- Programmable Active Droop™
- QFET®
- QS™
- Quiet Series™
- RapidConfigure™
- ™
- Saving our world, 1mW/W/kW at a time™
- SignalWise™
- SmartMax™
- SMART START™
- Solutions for Your Success™
- SPM®
- STEALTH™
- SuperFET®
- SuperSOT™-3
- SuperSOT™-6
- SuperSOT™-8
- SupreMOS®
- SyncFET™
- Sync-Lock™
- ®
- TinyBoost®
- TinyBuck®
- TinyCalc™
- TinyLogic®
- TINYOPTO™
- TinyPower™
- TinyPWM™
- TinyWire™
- TranSiC™
- TriFault Detect™
- TRUECURRENT®*
- μSerDes™
- ™
- UHC®
- Ultra FRFET™
- UniFET™
- VcX™
- VisualMax™
- VoltagePlus™
- XS™
- Xsens™
- 仙童®

* Trademarks of System General Corporation, used under license by Fairchild Semiconductor.

DISCLAIMER

FAIRCHILD SEMICONDUCTOR RESERVES THE RIGHT TO MAKE CHANGES WITHOUT FURTHER NOTICE TO ANY PRODUCTS HEREIN TO IMPROVE RELIABILITY, FUNCTION, OR DESIGN. TO OBTAIN THE LATEST, MOST UP-TO-DATE DATASHEET AND PRODUCT INFORMATION, VISIT OUR WEBSITE AT [HTTP://WWW.FAIRCHILDSEMI.COM](http://www.fairchildsemi.com). FAIRCHILD DOES NOT ASSUME ANY LIABILITY ARISING OUT OF THE APPLICATION OR USE OF ANY PRODUCT OR CIRCUIT DESCRIBED HEREIN; NEITHER DOES IT CONVEY ANY LICENSE UNDER ITS PATENT RIGHTS, NOR THE RIGHTS OF OTHERS. THESE SPECIFICATIONS DO NOT EXPAND THE TERMS OF FAIRCHILD'S WORLDWIDE TERMS AND CONDITIONS, SPECIFICALLY THE WARRANTY THEREIN, WHICH COVERS THESE PRODUCTS.

AUTHORIZED USE

Unless otherwise specified in this data sheet, this product is a standard commercial product and is not intended for use in applications that require extraordinary levels of quality and reliability. This product may not be used in the following applications, unless specifically approved in writing by a Fairchild officer: (1) automotive or other transportation, (2) military/aerospace, (3) any safety critical application – including life critical medical equipment – where the failure of the Fairchild product reasonably would be expected to result in personal injury, death or property damage. Customer's use of this product is subject to agreement of this Authorized Use policy. In the event of an unauthorized use of Fairchild's product, Fairchild accepts no liability in the event of product failure. In other respects, this product shall be subject to Fairchild's Worldwide Terms and Conditions of Sale, unless a separate agreement has been signed by both Parties.

ANTI-COUNTERFEITING POLICY

Fairchild Semiconductor Corporation's Anti-Counterfeiting Policy. Fairchild's Anti-Counterfeiting Policy is also stated on our external website, www.fairchildsemi.com, under Terms of Use

Counterfeiting of semiconductor parts is a growing problem in the industry. All manufacturers of semiconductor products are experiencing counterfeiting of their parts. Customers who inadvertently purchase counterfeit parts experience many problems such as loss of brand reputation, substandard performance, failed applications, and increased cost of production and manufacturing delays. Fairchild is taking strong measures to protect ourselves and our customers from the proliferation of counterfeit parts. Fairchild strongly encourages customers to purchase Fairchild parts either directly from Fairchild or from Authorized Fairchild Distributors who are listed by country on our web page cited above. Products customers buy either from Fairchild directly or from Authorized Fairchild Distributors are genuine parts, have full traceability, meet Fairchild's quality standards for handling and storage and provide access to Fairchild's full range of up-to-date technical and product information. Fairchild and our Authorized Distributors will stand behind all warranties and will appropriately address any warranty issues that may arise. Fairchild will not provide any warranty coverage or other assistance for parts bought from Unauthorized Sources. Fairchild is committed to combat this global problem and encourage our customers to do their part in stopping this practice by buying direct or from authorized distributors.

PRODUCT STATUS DEFINITIONS

Definition of Terms

Datasheet Identification	Product Status	Definition
Advance Information	Formative / In Design	Datasheet contains the design specifications for product development. Specifications may change in any manner without notice.
Preliminary	First Production	Datasheet contains preliminary data; supplementary data will be published at a later date. Fairchild Semiconductor reserves the right to make changes at any time without notice to improve design.
No Identification Needed	Full Production	Datasheet contains final specifications. Fairchild Semiconductor reserves the right to make changes at any time without notice to improve the design.
Obsolete	Not In Production	Datasheet contains specifications on a product that is discontinued by Fairchild Semiconductor. The datasheet is for reference information only.

Rev. I77